

# ST LOG

THE ATARI ST  
MONTHLY  
MAGAZINE

U.S.A. \$3.50  
CANADA \$4.75

SEPTEMBER 1987

ISSUE 17

## Figure 1

**Page Perfect**  
How to make your copy  
look professional

**Utilities**  
for the 520ST



### Desktop Publishing

September 1987

Volume 1, Number 1

Welcome to the first issue of our new Atari ST only Desktop Publishing newsletter. We hope that by reading these pages each month, you'll learn new and useful ways of utilizing your ST. Each month we will give you tips on how to produce the best layouts for your particular type of

as well as new ways of attaching hardware to existing pieces of plumbing. Perhaps then you'll expand your horizons and find a mullin for yourself as I have. Believe me when I say that I have nothing to

each new cycle can give stimulating... who place it in the... new laser printer... ary expansion... pieces such... ary or even... won spoken... you need... ll have to... something... d.

\$3.00

About two years ago, in response to Cuthill's invitation, I systematically set about landscaping our garden, making a park of it. I graded uneven ground into interesting terraces, sowed lawns, planted forsythia, lavender, hydrangea bushes, and roses. In addition I set out twenty-five lilacs of my own raising. Along the paths I have laid out beds of iris two and a half meters wide and fifty meters long. Today seedling pines, birches, and lindens were delivered. With such a wealth of plant materials I can begin to lay out a landscape garden.

The beautiful rose that was always here wasn't enough for me. I found myself finding it's body growing stronger with each day. It was like a breath of fresh air. Its arrival came at the right time. It seemed that when all else was lost, this beautiful rose was there to keep me going about two years ago, in response to Cuthill's invitation, I systematically set about landscaping our garden, making a park of it. I graded uneven ground into interesting terraces, sowed lawns, planted forsythia, lavender, hydrangea bushes, and roses. In addition I set out twenty-five lilacs of my own raising. Along the paths I have laid out beds of iris two and a half meters wide and fifty meters long. Today seedling pines, birches, and lindens were delivered. With such a wealth of plant materials I can begin to lay out a landscape garden.

ave laid out beds of iris two and a half meters wide and fifty meters long. Today seedling pines, birches, and lindens were delivered. With such a wealth of plant materials I can begin to lay out a landscape garden.

As if The beautiful rose that was always here wasn't enough for me. I found myself finding it's body growing stronger with each day. It was like a breath of fresh air. Its arrival came at the right time. It seemed that when all else was lost, this beautiful rose was there to keep me going about two years ago, in response to Cuthill's invitation, I systematically set about landscaping our garden, making a park of it. I graded uneven ground into interesting terraces, sowed lawns, planted forsythia, lavender, hydrangea bushes, and roses. In addition I set out twenty-five lilacs of my own raising. Along the paths I have laid out beds of iris two and a half meters wide and fifty meters long. Today seedling pines, birches, and lindens were delivered. With such a wealth of plant materials I can begin to lay out a landscape garden.

#### Desktop Publishing

At last there is a comprehensive page layout program for the Atari ST. You can see text, rules (lines) and columns in their actual size and position on the screen as you type and edit your page. Using Publishing Partner you can design, compose, and paste up a variety of publishing items including newsletters, forms, tables, ads, charts, and much more.

#### WYSIWYG

"What you see is what you get." You will see on the screen just how the page will look when it is printed, no more guesswork. You can adjust fonts, character sizes, and even character spacing anytime here on the page. You'll watch an ordinary letter transform into a professional looking "piece" right before your eyes as you experiment with mixing graphics and text.

#### Benefits

The benefits of using Publishing Partner are unlimited. By having a word processor and layout program, you'll be able to quickly and easily create a variety of documents. With Publishing Partner it's easy to understand "drop-down" menus, learning and using the program will be instantaneous.

#### Suggested Equipment

In order to use Publishing Partner, all you need is an Atari 520 ST, 1040 ST, or upward compatible machine. Both color and monochrome monitors are supported but monochrome is recommended. Supported printers include Epson and LaserWriter compatible, Star (Gammal), Apple device. New print drivers are being released daily so call to make sure your printer is supported.

the fonts are loaded by the user. Additional fonts can be placed on the working disk once the user has defined the type style. If you use the mouse and click on the displayed point size, you will see a dialog box prompting you to enter a specific point size. You can enter a number between 2 and 216. The largest point size that can be displayed on the screen will be 72 points. If you enter a point size larger than the selected point size, you will see a 72 point character on the screen and horizontal spacing for the selected point size. For example, if you enter a 200 point character, the actual character will be for a 200 point character. Thus you will still have an accurate representation of the printed page.

Under the option labeled "Fonts in Memory" you can select one of the screen fonts by simply clicking the desired font on the left mouse button. Positioning the font has been selected and pressing the font has been selected, you will know the font which was highlighted prior to choosing this option, because it will appear next to the option labeled "Font." If you have text which was highlighted prior to choosing this option, the highlighted text will change accordingly to the font you just selected after selecting OK. If no text was highlighted prior to choosing a new font, then the newly selected font will be used when you start entering text.

Next to the prompt "Point," you will see the currently selected point size. Directly underneath this prompt, you will see a window displaying additional point sizes. You can select any point size between 3 and 72 points (see attributes TALL and WIDE) by using the mouse and positioning the pointer over the desired number and clicking the left mouse button. If you wish to view what's being displayed in a smaller size window, you should use the "point size" window, you should use the mouse and click on the scroll bar arrows to view additional point sizes.

Under the option labeled "Fonts in Memory" you can select one of the screen fonts by simply clicking the desired font on the left mouse button. Positioning the font has been selected and pressing the font has been selected, you will know the font which was highlighted prior to choosing this option, because it will appear next to the option labeled "Font." If you have text which was highlighted prior to choosing this option, the highlighted text will change accordingly to the font you just selected after selecting OK. If no text was highlighted prior to choosing a new font, then the newly selected font will be used when you start entering text.

If you have selected attributes from the STYLE menu without previously highlighting text, you will notice a check mark appears next to them. As you type, the selected attributes are displayed on the screen. If you wish to turn off one of the attributes, follow the same procedure as when you turned it on.

Next to the prompt "Point," you will see the currently selected point size. Directly underneath this prompt, you will see a window displaying additional point sizes. You can select any point size between 3 and 72 points (see attributes TALL and WIDE) by using the mouse and positioning the pointer over the desired number and clicking the left mouse button. If you wish to view what's being displayed in a smaller size window, you should use the "point size" window, you should use the mouse and click on the scroll bar arrows to view additional point sizes.

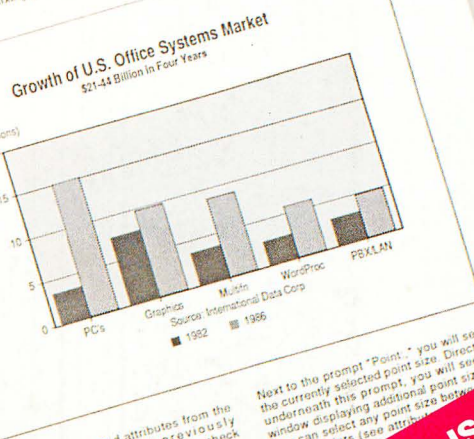

**ON THIS ISSUE'S DISK VERSION:**  
**An Atari 800 Emulator**  
**THE ST XFORMER**



# BREACH

"I was moving a squad of four of my best through the *kehst*-beridden jungles of Kiskismok, when suddenly Darrow's detector picks up what looks like a couple of life forms 50 meters out."

"'Nothin' but a couple of those brachiators,' he says to me. Just then Darrow takes it through the chest."

"We all drop into the mud, flipping through our helmet displays trying to find out where the shot came from when I hear this rumbling. More like I *feel* this rumbling. An' then there it is. A battle robot."

"Hsiang shoots the thing in its sensory grid with a bolt, but it doesn't do much good 'cause he's a psionic talent and they don't give 'em half-way decent guns. It starts tracking him with its dual guns and suddenly he takes some hot plasma too. Now it's just me and the kid, Yamaguchi."

"'Guchi,' I said, 'Direct your fire into the lifters so it can't move. These things are pretty lousy about protecting their undersides.' So like he was a vet of 20 drops, he rises to one knee and hits the thing right in the lifters. And then he does it twice more."

"'One battle robot: out of action,' he says. I toss an energy grenade at the hulk just to make sure and then we start the long job of carrying the boys north, where we know the landing boat'll be."

**The Serayachi Campaign**—Sgt. Robert Sherwood, FWSF Ret.

**Breach** is a single-player tactical-level combat game for one person. It features:

- Smooth animated movement and combat.
- Macintosh™ version includes digitized sound.
- The ability to lead squads of up to 20 marines.
- A campaign of several scenarios included with the game.
- Up to 40 opponents per scenario—ranging from vicious beasts to marines as intelligent and well-equipped as your own. Six different classes of opponents in all: marine, alien, beast, overlord, autogun, and battle robot.
- Equip your marines with 20 different types of objects—including rocket launchers, demolition charges, first aid kits, and cracking units to break into enemy computer systems.
- Four different classes of marine: marauder, infiltrator, scout, and psionic talent.
- Your squad leader is independent of any scenario—play **Breach** just like a role-playing game or as a single session wargame.
- Build-up your squad leader for special advanced training—all of his combat experience is saved!
- **Breach** includes a **Scenario Builder**—create your own scenarios or modify existing ones!
- Scenarios can have several different victory conditions which can be mixed together to form extremely complex battles.
- Additional scenario disks available soon!

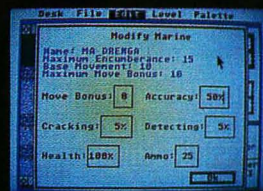

*Breach* is available for the Atari ST and Macintosh. IBM version available soon. Photos are for the Atari ST version.

To order, visit your software dealer. For direct orders (VISA/MasterCard/COD), phone (203) 658-6917. To purchase by mail, send check, money order, or credit card information to Omnitrend Software, Inc., PO Box 733, West Simsbury, CT 06092. Cost is \$39.95 plus \$3.00 for shipping and handling.

  
**OMNITREND**  
**SOFTWARE**  
P.O. BOX 733 • WEST SIMSBURY, CT 06092

## FEATURES

Publishing, partner! Guidelines and tips on how to use Publishing Partner.	Matthew Stern	9
Floyd the Droid on the Run <i>A special inclusion—listings on disk and Delphi.</i> Part two of our contest-winning program, the high-resolution version.	Paul Lay	13
AutoTransfer Why transfer files to your RAMdisk manually? Use AutoTransfer, a partner program to RAMmer.	Maloney	17
Utilities for the 520ST The right utilities can make your computing life easy. Here's a look at what's available.	Arthur Leyenberger	21
RAMmer Stop the disk-swapping nightmare by giving your ST its own RAMdisk. It's only logical.	Maloney	31
Inside the ST Xformer <i>A special inclusion—listings on disk and Delphi.</i> Run many Atari 8-bit programs on your ST with this emulator.	Darek Mihocka	43
Page Perfect An introduction to the world of composition for do-it-yourself publishers.	Maurice Molyneaux	49
Step 1: Processed Prose Word processors—use your digital "blender" to its best advantage.	Maurice Molyneaux	61
Status report Behind the Atari scene at CES.	D.F. Scott	67
ST Clip-Art Contest winners		76

## REVIEWS

ComputerEyes (Digital Vision) ST owners finally have their very own digitizer. Is it as good as its 8-bit predecessor?	Andy Eddy	35
Aegis Animator (Aegis Development) A moving review of the first animator for the ST.	D.F. Scott	36
Fleet Street Publisher (MirrorSoft Ltd.) A U.K. offering to bring publishing to your home and/or office.	D.F. Scott	37
Easy Draw (Migraph, Inc.) A look at the object-drawing software and its uses.	Matthew J.W. Ratcliff	41
Thinking man's gaming What are the best strategy games on the ST?	Bill Kunkel, Arnie Katz and Joyce Worley	55
Star Fleet I (Electronic Arts) A Star-Trek-like world comes to the ST line.	Andy Eddy	57
Donald Duck's Playground (Sierra On-Line, Inc.) Learning concepts with Unca' Donald is child's play.	Joyce Worley	58
QMS-PS 800+ (QMS, Inc.) How does the PostScript laser printer stack up?	Charles Bachand	79
Barbarian (Psygnosis Ltd.) Can you destroy the crystal? Will you want to?	Michael J. DesChenes	82

## COLUMNS

Editorial	Lee H. Pappas	4
Reader comment		6
ST news		14
ST user	Arthur Leyenberger	26
Database Delphi	Matthew J.W. Ratcliff	29
Atari Users' Groups		53
Scheduled Atari Fairs		65
Ian's Quest	Ian Chadwick	70
C-manship	Clayton Walnum	73
Index to Advertisers		84

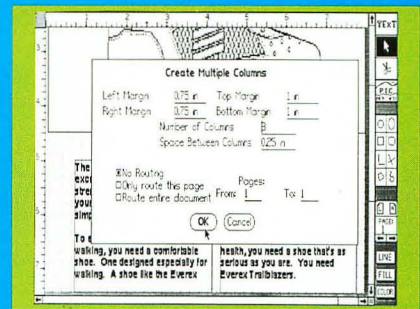

9

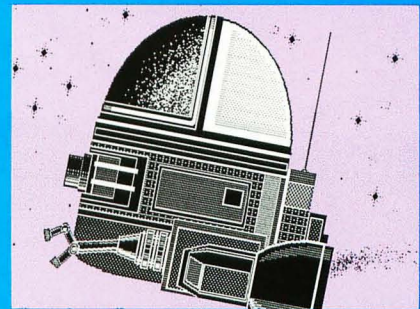

13

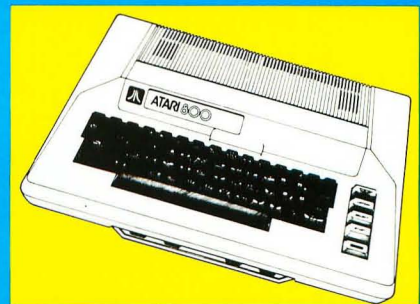

43

# The Informer™

**"Why can't there be a great database file manager for the ST?"**

We weren't looking for a small improvement over the existing database file managers for the Atari ST. We were shooting for a major new system that pushed the ST's powerful features to the limit. No other database for the ST has The Informer's impressive graphics ability or its ease-of-use.

Other databases restrict your Atari ST's incredible graphics capabilities. With The Informer you can easily use text *and* graphics in your databases. Point-and-click to use pictures, graphs, and drawings from Degas™ and Neochrome™.

No programming is required to use The Informer. Easy point-and-click functions are used to create and

manipulate any of up to four databases simultaneously. Information is stored in a database like a spreadsheet.

Customizing reports is easy. Just point-and-click the mouse. Reports and graphics may be printed as they appear on the screen.

The Informer is compatible with data from Habaview™, Regent Base™, and dbMan™.

We even offer a Trial Pak including a demonstration disk with examples available for only \$19.95. The cost is good towards a purchase of The Informer.

The Informer, *a graphic database of unprecedented power.*

The Informer is a trademark of Regent Software.  
Habaview is a trademark of Haba Systems.  
dbMan is a trademark of Versasoft.  
Degas is a trademark of Batteries Included.  
Neochrome is a trademark of Atari Corp.

The screenshot displays the 'Herkimer Homes' database. At the top, a menu bar includes 'Desk', 'File', 'Column', 'Display', 'Print', 'Math', 'Sequence', and 'Estimates'. Below the menu, a header reads 'Herkimer Homes' with the tagline 'Good Living for Good Pay'. A total amount of '\$1,000,000.00' is shown. An 'Invoice' window is open, showing a date of '06/01/87' and a total of '\$48,888.48'. A table with columns for 'Description', 'Quantity', 'Unit Price', and 'Extension' is visible. The table contains the following data:

Description	Quantity	Unit Price	Extension
185		\$ 42.00	\$ 7770.00
		\$ 19.00	\$ 4370.00
		\$ 4.75	\$ 3087.50
		\$ 3.00	\$ 261.00
		\$ 1.15	\$ 748.65
		\$ .30	\$ 1260.00
		\$ .41	\$ 166.00

**Regent**  
SOFTWARE

7131 Owensmouth Avenue, Suite 45A  
Canoga Park, CA 91303 (818) 882-2800

CIRCLE #102 ON READER SERVICE CARD

\$ 900.00 \$ 8100

# MOVING?

## DON'T MISS A SINGLE ISSUE

Let us know your new address right away. Attach an old mailing label in the space provided below and print your new address where indicated.

### DO YOU HAVE A QUESTION ABOUT YOUR SUBSCRIPTION?

Check the appropriate boxes below:

- New subscription. Please allow 4 to 8 weeks for your first copy to be mailed.
- Renewal subscription. Please include a current address label to insure prompt and proper extension.
- 1 year — \$28.00. This rate limited to the U.S. and its possessions.
- Payment enclosed.  Bill me.

MAIL TO: **ST-LOG**, P.O. BOX 625, HOLMES, PA 19043

Name \_\_\_\_\_

Street Address \_\_\_\_\_

City \_\_\_\_\_ State \_\_\_\_\_ Zip \_\_\_\_\_

ATTACH LABEL HERE

(IF LABEL IS NOT HANDY, PRINT OLD ADDRESS IN THIS SPACE)

## ST-Log Staff

*Editors/Publishers:* Michael J. DesChenes, Lee H. Pappas. *Managing Editor:* Diane L. Gaw. *Technical Editors:* Charles Bachand, Clayton Walnum. *East Coast Editor:* Arthur Leyenberger. *Midwest Editor:* Matthew J.W. Ratcliff. *West Coast Editor:* Charles F. Johnson. *Contributing Editors:* Ian Chadwick, Arnie Katz, Bill Kunkel, Maurice Molyneaux, Steve Panak, D.F. Scott, Douglas Weir, Joyce Worley. *Cover photo:* Jim Langone. *Contributing Artist:* Gary Lippincott. *Production Editor:* Kathy Wiesner. *Graphics:* Connie Moore. *Typography:* Edythe Stoddard, Lisa Openshaw. *Advertising Manager:* Michael J. DesChenes. *Accounting/ Circulation:* Robin Levitsky. *Contributors:* Andy Eddy, Paul Lay, Maloney, Darek Mihocka, Matthew Stern. U.S. newsstand distribution by Eastern News Distributors, Inc., 1130 Cleveland Rd., Sandusky, OH 44870.

**ST-Log** magazine (ANALOG 400/800 Corp.) is in no way affiliated with Atari. Atari is a trademark of Atari Corp.

## Where to write

All editorial material (programs, articles, letters and press releases) should be sent to: Editor, **ST-Log**, P.O. Box 23, Worcester, MA 01603.

Correspondence regarding subscriptions, including problems and changes of address, should be sent to: **ST-Log**, 100 Pine Street, Holmes, PA 19043, or call 1-800-345-8112.

Correspondence concerning a regular column should be sent to our editorial address, with the name of the column included in the address. We cannot reply to all letters in these pages, so if you would like an answer, please enclose a self-addressed, stamped envelope.

## Advertising Sales

### East Coast

Gerald F. Sweeney & Associates — (212) 242-3540  
P.O. Box 662, New York, NY 10113

### West Coast

J.E. Publishers Representatives — Los Angeles: (213) 467-2266.  
San Francisco: (415) 864-3252. Chicago: (312) 445-2489.  
Denver: (303) 595-4331.  
6855 Santa Monica Blvd., Suite 200, Los Angeles, CA 90038

### ST-Log offices

Michael Des Chenes, National Advertising — (617) 892-9230

Address all advertising materials to: Michael Des Chenes — Advertising Production, **ST-Log**, 565 Main Street, Cherry Valley, MA 01611.

## Permissions

No portion of this magazine may be reproduced in any form without written permission from the publisher. Many of the programs printed herein are copyrighted and not public domain.

Due, however, to numerous requests from Atari club libraries and bulletin board systems, our policy does allow club libraries or individually-run BBSs to make certain programs from **ST-Log** available during the month printed on that issue's cover. For example, software from the January issue can be made available January 1.

This does not apply to programs which specifically state that they are *not* public domain and, thus, are not for public distribution.

In addition, any programs used must state that they are taken from **ST-Log** magazine. For further information, contact **ST-Log** at (617) 892-3488.

## Subscriptions

**ST-Log**, P.O. Box 625, Holmes, PA 19043; or call toll-free: 1-800-345-8112. Payable in U.S. funds only. U.S.: \$28.00-1 year; \$52.00-2 years; \$76.00-3 years. Canada: \$36.00-1 year; \$68.00-2 years; \$99.00-3 years. Foreign: \$39.00-1 year; \$72.00-2 years; \$104.00-3 years. For disk subscriptions, see the cards at the back of this issue.

## Authors

When submitting articles and programs, both program listings and text should be provided in printed *and* magnetic form, if possible. Typed or printed text copy is mandatory, and should be in upper- and lowercase, with double spacing. If a submission is to be returned, please send a self-addressed, stamped envelope.

# Editorial

No question about it. Atari is taking the lead among computer companies when it comes to music. As far as the music industry is concerned, the ST is better than the PC, far superior to the Mac and could beat the Commodore any day.

And when I say "the music industry," I'm not talking about your local band. I'm talking about the likes of Peter Gabriel, The Pointer Sisters and one of the world's leading electronic music composers, Jean Michael Jarre, among others.

As I mentioned last issue, Atari was the first computer-oriented company to exhibit at the National Association of Music Merchants (NAMM) Show, in Chicago last June. As the only computer magazine exhibitor to work the Atari display, what I saw was nothing short of amazing.

Attendees wandered over to the Atari information desk in droves, asking "Why is a games company here?" Well, a tour of the computers on display showed ST after ST, beaming forth the latest in MIDI and music products, for composers and musicians alike.

ST developers showing at NAMM included Beam Team, Dr. T's, Hybrid Arts, Korg, Passport and Sonus. Beam Team, a West German company, showed a series of programs consisting of Xsyn, The Manager, Sound Bank Manager, Sound Creator, Sequencer and Sound Editor. Two other products, Xnotes and Xtrack, were offered, as well.

Visitors to the Dr. T's display drooled over Digital Drum Editor Librarian, a product developed for Korg, a leading manufacturer of keyboard, piano and drum synthesizers. Dr. T's also offers a MIDI Recording Studio and Keyboard Controlled Sequencer, plus some scoring titles and various patch libraries.

Passport Designs, Inc. has been selling Midisoft Studio, a multi-track recording studio, for some time now. They also recently announced Master Tracks Pro, a professional sequencer previously available for the Macintosh only.

Sonus Corp. had a large exhibit area which included—among other products—MasterPiece, a sequencing package in which data files are compatible with Sonus's SuperScore music scoring program.

And dominating most of the Atari booth was Hybrid Arts, demonstrating their full line of MIDI products—both hardware and software. A range of recorders and patch librarians, as well as the remarkable ADAP SoundRack hardware were all strutting their stuff. A small cubicle, manned by Hybrid's President Bob Moore, blasted tunes from a *Top Gun* compact disc, which had been transferred to a Mega ST, then modified and displayed in a variety of ways.

Finally, the clincher came when one member of the Chicago Atari Groups tallied up the number of computers visible during the show. There were more STs present than all of the other brands—combined! The attendees were surprised and impressed. . . . And you know what? So was I.

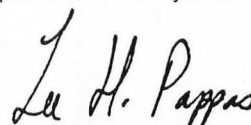

Lee H. Pappas  
Publisher  
ST-Log

# HERE, BY POPULAR DEMAND, OS-9 FOR THE ATARI ST

Up until now, if you wanted a true multi-tasking environment on an Atari, you were out of luck. The concept of powerful system software on personal computers was just that, a concept, not reality. But not any more!

## OS-9 for the ST!

Introducing multi-tasking support for the Atari-ST: OS-9/ST. Now you can have a professional operating system that delivers real-time performance and a UNIX-style system environment.

## Choose Personal or Professional

OS-9/ST is available in two flexible configurations: Personal and Professional.

- Personal OS-9/ST combines the power of OS-9 with an interactive, structured Basic and handy utility

set; plus easy-to-use, easy-to-read documentation for the neophytes among us.

- Professional OS-9/ST turns your Atari ST into a full C Language workstation. You'll open new doors with your ST using the powerful Assembler, Linker and User Debugger. And if that's not enough, you can add optional tools like Pascal, FORTRAN, Electronic Mail, Print Spooler and other popular productivity packages.

## Support ANYTIME You Need It!

Included with both versions of OS-9/ST is twenty-four-hours, seven days-a-week "support" — via your modem and CompuServe. And while you're there, browse through the OS-9 User Group Libraries or leave a message for your friends.

With either version you'll get true multi-user support and the software tools to exploit it. And with your purchase of OS-9/ST, you'll receive a free copy of the OS-9 Software Sourcebook — a valuable reference guide to third-party software. For further information, call Microware today, or contact your local distributor to find out how to put the power of OS-9/ST to work for you!

Personal OS-9/ST \$150.00  
Professional OS-9/ST \$600.00



Microware Systems Corporation  
1900 N.W. 114th Street  
Des Moines, Iowa 50322  
Phone 515-224-1929

Microware Japan, Ltd.  
41-19 Honcho 4-Chome, Funabashi City  
Chiba 273, Japan  
Phone 0473 (28) 4493  
Telex 781-299-3122

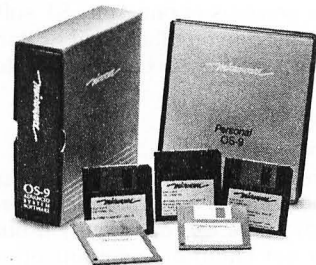

Micomaster Scandinavian AB  
S:1 Persgatan 7  
Box 1309  
S751-43 Uppsala  
Sweden  
Phone: 018-138595  
Telex: 76129

Dr. Rudolf Keil, GmbH  
Porphystrasse 15  
D-6905 Schriesheim  
West Germany  
Phone: (0 62 03) 67 41  
Telex: 465025

Eisoft AG  
Zelweg 12  
CH-5405 Baden-Dattwil  
Switzerland  
Phone: (056) 83-3377  
Telex: 828275

Vivaway Ltd.  
36-38 John Street  
Luton, Bedfordshire, LU1 2JE  
United Kingdom  
Phone: (0582) 423425  
Telex: 825115

Microprocessor Consultants  
92 Bynya Road  
Palm Beach 2108  
NSW Australia  
Phone: 02-919-4917

Microdata Soft  
97 bis, rue de Colombes  
92400 Courbevoise  
France  
Phone: 1-768-80-80  
Telex: 615405

# Reader comment

## A word from Prospero.

Thank you for including our company's products in the special feature entitled "Language overview," which appeared in the June edition of **ST-Log** (issue 15), pages 9 and 10.

May I point out that the recommended retail price of Pro Fortran-77 for the Atari ST is \$149, not \$199.95 as given in the feature. The software has been priced at \$149 since its launch in March 1986.

We were disappointed too that no mention was made of Pro Pascal among the Pascal compilers for the Atari ST listed in the same feature. Prospero's Pro Pascal is of equal quality, speed and reliability as our Fortran-77, and retails for the same price of \$149.

It has always been Prospero's policy to improve and update products in line with what our users are asking us for, and so, in late summer, we shall be announcing major new versions of our Atari ST software. I shall send your Technical Editors review copies as they become available.

Yours faithfully,  
Margaret Mohan  
Prospero Software Ltd.

*Sorry, folks. Our editors did try to contact all companies whose products were to be listed. There was apparently a link missing in our chain of communication with the U.K.* —Ed.

## PrinterFont update.

The following lines should be substituted into issue 15's "PrinterFont."  
**1510 if brand>1 then goto**

```
xy 5,10:print "0"
2380 lprint"1234567890 !@
#$^&*()_+--=^`{}|:;'"<, > .?
/\\"
2400 BLD:lprint e$"E"o$;:
return
```

## A continuing saga . . .

After reading your response to my letter [both published in **ST-Log** 15] in your June issue, I feel several parts of my letter have been misinterpreted.

GEM is definitely here to stay. I realize a bug-free operating system will require several years, if not more, to be fully developed; UNIX is an excellent example. However, I do feel that GEM will never be optimized to reveal the full potential of the ST. Atari Corp. simply doesn't have the time, nor resources, to rewrite GEM for the MC68000. In addition, the GEM operating system will not work in any future 32-bit machine. A faster GEM will have to come from DRI. And that, given the current situations, seems virtually impossible.

As for the NS32000 series, I am fully aware that a floating point is optional. The importance is that National's 16-bit version of their microprocessor has that option fully supported in the hardware of the CPU. Motorola made no such provisions in the MC68000.

In my last letter, I did not wish to debate the merits of one microprocessor over another. A debate was not my intent, but the advantages of the NS32000 series over the MC68000 series are obvious. In fact, they go far beyond "fancy micro-

code." Some of the advantages are: (1) upward and downward compatibility; (2) real memory management for the whole NS32000 line, providing memory protection and address translation; and (3) completely orthogonal and symmetrical instruction set.

A study of the MC68000 lines will reveal the MC68010 to be an incompletely "patched" MC68000. Motorola designed the features missing in the MC68000 into the MC68020, but the unfortunate result was incompatibility between these two chips. Therefore, any future 32-bit system from Atari will have to emulate the ST by using a MC68000 coprocessor card, or by software, which would be very slow.

The NS32000 series also did exist during the design of the ST. National Semiconductor finished their design in 1981. The NS32000 series was commercially available in 1982. And, during the design of the ST, Atari is rumored to have built a computer utilizing the NS32016 or the NS32032.

At the time, the NS32032 may have been relatively new (a year or two old), but the microprocessor had already been debugged by its 16-bit data path predecessor. The NS32032 is simply an NS32016 with a 32-bit data path. (The ease of extending the NS32016 to a 32-bit one is another indication of National's clean architecture.)

Atari is also rumored to have been developing an NS32332 (at 2 to 3 times the performance of the NS32032) computer in

*(continued on page 66)*



ATARI ST

# PUBLISHING PARTNER™

CREATES LIKE A PUBLISHING COMPANY WITHOUT THE OVERHEAD

SOFT LOGIK NEWS

## PUBLISHING PARTNER™ HELPS YOU CREATE!

You'll benefit by using your Atari ST to create professional quality journals, newsletters, ads, business cards, certificates, letterheads, logos, art designs, bar graphs, flow charts, *even bumper stickers* and all the forms you or anyone would ever need. Create just like a professional publishing company without the overhead! Publishing Partner is actually three programs in one--Word Processor, Page Layout, and Forms Creator. Expand your potential in becoming a better writer, artist and designer with your Publishing Partner.

AVAILABLE FOR ONLY \$149.<sup>95</sup>

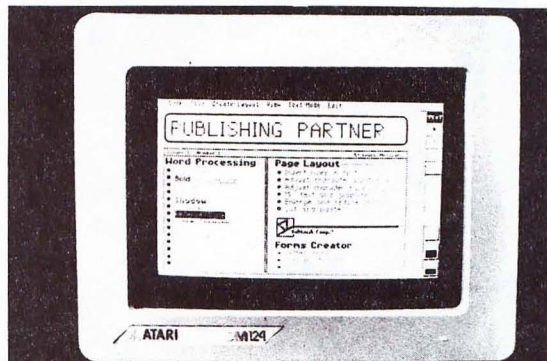

## WORD PROCESSING PAGE LAYOUT FORMS CREATOR

### What you see is what you get!

Combine text and graphics easily and quickly from existing or newly created documents. Position entire paragraphs or individual words exactly where you want them. Create one, or multiple color separations ready for printing. Production time will never be the same--it will be much shorter!!

Just take a look at some of its features!

- \* GEM based
- \* Justifies right or left as you type
- \* Edit Multiple Columns on One Screen
- \* Search and Replace
- \* User Definable Page Size
- \* **Bold**, underline, <sup>super</sup> and subscript
- \* *Italicize*, **shadow**, **outline**
- \* **Reverse Image**
- \* Backslant Characters
- \* Mirror Image      Invert Image
- \* egrsmI 1011M      \* 1u1e1t 1w1e1g1e
- \* Auto Headers/Footers, Page Numbers
- \* Easily Move Text
- \* Reads & Merges other files together
- \* Sets Tabs
- \* Macros
- \* Vertical & Horizontal Printing

Whatever you require--cutting artwork from other programs, custom logos, unique borders, unusual mastheads, digitized photos--Publishing Partner is your solution. After all, it was specially designed for you--the home and/or office Atari ST user--by the pro's who realize that there's more to your computer than just typing letters.

- \* Vert. and Horz. rules--Exact Alignment
- \* Auto Text flow for columns/pages
- \* Layout Multiple Columns of text
- \* Change columns on finished page
- \* Display entire page, 50%, or 25%
- \* Easily Re-position Text and Graphics
- \* Alternating Headers/Footers
- \* Mix Type, Fonts, and Sizes *anywhere*
- \* Adjust Sizes from 2pts to 144 pts (2")
- \* Adjust line spacing (leading) by points
- \* Import other program's graphics
- \* Rotate Graphic Images
- \* Multiple Patterns, Shades and Colors
- \* Enlarge & Reduce Graphics/Exact fit
- \* Cut, Paste & Crop Graphics
- \* Tool box function/Unlimited patterns
- \* Boxes, Circles, Arcs, Polygons, etc.
- \* Insert lines directly on the page
- \* Adjust Character Spacing
- \* Use Hairlines to separate columns

You can create a variety of forms quickly and easily with your Publishing Partner.

For example, you can create your own:

- Letterhead
  - Invoices
  - Purchase Orders
  - Labels
  - Bumper Stickers
  - Business Cards
  - Certificates
  - General Ledger
  - Shipping and Receiving
  - Routing Slips
  - "While you were out" Phone messages
  - Templates
  - Price Estimate forms
  - Requisition forms
  - Shipping Logs and much more!
- Publishing Partner supports most dot matrix printers, including the Epson™ Star™ and Okidata™ Printers. Also supported are any Postscript output devices such as the Apple Laserwriter™. New print drivers are constantly being released, *so please call to make sure your printer is supported.*
- FOR MORE INFORMATION OR TO PLACE AN ORDER, CALL (314)894-8608. DEALER INQUIRES INVITED.

CIRCLE #104 ON READER SERVICE CARD



Soft Logik Corp.™

4129 OLD BAUMGARTNER \* ST. LOUIS, MO. 63129 \* CALL (314) 894-8608

# F-15 STRIKE EAGLE®

## Often Imitated—Never Equaled



Now the focus  
of a new book



I decided early on to develop this book with the F-15 STRIKE EAGLE simulation in mind. I chose F-15 largely because of the high quality in-flight simulation characteristics and the variety of weapons available.

Richard G. Sheffield, author  
(COMPUTE! Books)



**Major Bill Stealey**  
MicroProse President  
USAF Reserve

### The First, The Best, The Only Real Combat Flight Simulator

It takes a unique combination of talents to produce a blockbuster, best-seller like **F-15 STRIKE EAGLE**, the original combat jet simulation. And only MicroProse Software, the world leader in flight simulation development, can boast of uniting the expertise and ingenuity of two personalities like Major Bill Stealey, a former USAF jet fighter pilot with over 3000 flying hours, and

Sid Meier, the legendary computer game designer whose programs have sold well over 1 million copies.

In **F-15 STRIKE EAGLE** you don't just control the flight of a high-tech plane... you also guide the outcome of 7 different historical combat missions. You'll defend the freedom of the skies with Sidewinder and Sparrow missiles, MK-82 bombs and 20mm cannon. The Heads-Up Display (HUD)

gives you immediate feedback... and you'll need it to evade the enemy with your multi-range radar, electronic jamming devices and decoy flares.

Face the challenge of modern jet combat in **F-15 STRIKE EAGLE**, now being flown by more than 400,000 satisfied computer pilots.

Now **EGA** enhanced for IBM-PC/jr./XT/AT and compatibles, and **NEW** for Atari-ST. Also available for Apple II+/c/e, Commodore 64/128 and Atari XL/XE. Suggested retail price is \$34.95 (Atari ST-\$39.95).

Available now at the **Valued MicroProse Retailer (VMR)** nearest you.



IBM/EGA screen shown.

# MICROPROSE™

SIMULATION • SOFTWARE

120 Lakelure Drive • Hunt Valley, MD 21030 • 771-1151

Registered trademarks of International Business Machines, Inc., Atari, Inc., Apple Computer Inc., and Commodore Electronics Ltd.

CIRCLE #105 ON READER SERVICE CARD

# Publishing Partner™

Desktop Publishing for the Atari ST

## FEATURE TUTORIAL

New for the Atari ST

Only \$149.95

### Desktop Publishing

At last there is a comprehensive page layout program for the Atari ST. You can see text, rules (lines) and columns in their actual size and position on the screen as you type and edit your page. Using Publishing Partner™ you can design, compose, and paste up a variety of publishing items including newsletters, forms, tables, ads, charts, and much more.

### WYSIWYG

"What you see is what you get." You will see on the screen just how the page will look when it is printed—no more guess work. You can adjust fonts, character sizes, and even character spacing anytime and anywhere on the page. You'll watch an ordinary letter transform into a professional looking "piece" right before your eyes as you experiment with mixing graphics and text.

### Benefits

The benefits of using Publishing Partner are unlimited. By having a word processor, page layout, and forms creator all in one program, you'll be able to quickly and easily create a variety of documents. With Publishing Partner's easy to understand "drop-down" menus, learning and using the program will be instantaneous.

8 point  
12 point

24 point

36 point

72 pt

up to 144 points

### Special Attributes

Backslant  
Bold  
Double Underline  
Italicize  
Light  
Mirror romiM  
Outline  
Reverse Type  
Shadow  
Strike-through  
Tall  
Underline  
Upside Down  
Wide

You can mix and match any attribute you desire!

For example:

Tall and Shadow  
Italicize, Outline, and underline

### Suggested Equipment

In order to use Publishing Partner, all you need is an Atari 520 ST, 1040 ST, or upward compatible machine. Both color and monochrome monitors are suggested.



You can reduce, enlarge, or "cut" any Degas™ or Neochrome™ picture

To place an order:  
Just call (314) 894-8608 or mail payment to:

SoftLogik Corp  
4129 Old Baumgartner  
St. Louis, MO 63129  
(314) 894-8608

Produced with Publishing Partner, and an Atari ST

# Publishing, partner!

## A session on the capabilities and use of Publishing Partner.

by Matthew Stern

They say the power of the press belongs to those who own one. But a press isn't much good unless you know how to use it.

SoftLogik's **Publishing Partner** is one of the most popular desktop publishing tools for the Atari ST. This tutorial will show you how to harness this program's power and use it to create professional, camera-ready work.

As an example, I'll show you how I used **Publishing Partner** to create the advertisement shown in Figure 1, but you'll find the tools discussed here useful for other types of projects, as well.

### How Publishing Partner works.

When you send your newsletter, advertisement, etc., to be produced at a print shop, a typesetter sets the copy in different fonts and sizes; a graphic artist produces the artwork; and a pasteup person places these materials on the page.

A page composition program like **Publishing Partner** can produce similar results right at your own ST. You can set, write or paste up documents, using different typstyles, incorporate some art from graphics programs, draw borders and simple line art, and design sophisticated page layouts.

You don't need to be a typesetter, graphic artist or layout person to use this program. All that's necessary is a good eye for design.

### Equipment you'll need.

I used **Publishing Partner** on an unexpended 520ST with a color monitor. This isn't the optimum configuration, but it proves you can run this program on almost any ST system.

Ideally, you should use **Publishing Partner** on a monochrome system that has 1 megabyte or more RAM. A monochrome display is easier to read, has a higher resolution and shows more precise screen locations. Since your document's size is limited by memory, the more RAM you have, the better.

If you want to use this program in color, it will run in medium resolution only. Therefore, you shouldn't use it with a TV set.

**Publishing Partner** is best suited for laser printing. Not only do the laser printers produce beautiful, near-typeset-quality work, they're also faster than dot-matrix printers. Two types of laser printers are supported: the Hewlett-Packard Laserjet and compatibles, and PostScript printers like the Apple LaserWriter and the QMS PS800.

Because many of us can't afford a laser printer, **Publishing Partner** was designed to support dot-matrix printers, as well. The dot-matrix print quality isn't as good as laser printed material, though it's fine for rough drafts.

Luckily, you don't need a laser printer to get laser output. SoftLogik offers a laser printing service. You can send your document files on disk, and, for a small

fee, SoftLogik will print them up for you. Some Atari dealers offer a similar service; CalCom of Buena Park, California prints **Publishing Partner** documents for \$2 per page.

### Incorporating pictures.

**Publishing Partner** is designed to put words and pictures together. The program comes with some drawing functions and word processing features of its own, but you can create your text and art with other programs.

For the example ad, I created the shoe drawing and logo with DEGAS Elite. You can also import Neo-Chrome files.

I drew my illustrations in medium resolution using only black-and-white. I chose medium resolution because the art looks better when reduced. **Publishing Partner** can accept low resolution color artwork, but, when it reads color art, it converts the colors to shades. Drawing in black-and-white will give you a better representation of how your art will look on the printed page.

If you're not an artist, you can find collections of ready-made clip art in user's groups and on-line services. Be sure the files are converted to Neo-Chrome or DEGAS format. (.TNY, .ARC or compressed files cannot be used.)

When importing graphics, **Publishing Partner** reads an entire picture file and holds it in a "PIC" area. From this area, you can cut or copy pieces of your art and paste them into your document. You can save disk space by drawing many pieces

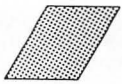

of art in a single file, then cut or copy from the PIC area as needed.

**Publishing Partner** can read ASCII (text only) files from other word processors. While it does have some editing features (like search and replace), you may feel more comfortable with your word processor's spelling checker, outliner and other text-handling tools.

If you have outside writers producing copy, they don't need to have **Publishing Partner**, or even an Atari ST. Have them save their files in "unformatted" or "non-document" mode. If they didn't write their stories on an ST, they can send them to you over the modem.

### Creating precise layouts.

Now that I have my artwork and copy on file, I'm ready to fire up **Publishing Partner** and start laying out my ad.

Professional layout artists begin a page design by drawing boxes for the art and text on a sheet of paper. This program works the same way.

When starting the program, you see a blank page. (Usually, it has a grid on it, which can be turned off.) To draw a box, click on an empty space on the page, drag the mouse to the desired location, and release the mouse button. I used this method to draw the large boxes for the headline and shoe graphic.

When I wanted to change the size of a box, I dragged the four handles on the corners. To move a box around, put the pointer in the center of the box, hold down the mouse button, and drag it to the new position.

At the bottom of the ad, I wanted two columns of text, both with the same width and margins, so I selected "Create Columns" from the create-layout menu. There, I specified the margins, number of columns and space between columns (see Figure 2). This was easier than trying to draw the column boxes individually.

In fact, you can set exact dimensions for any object on the page by pressing ALT-E (for edit). A dialog box will show the object's exact size and location. You may then move or resize the object by changing these numbers.

### Style sheets.

Consistency is the key to an attractive document. For example, you don't want your text in 10-point Helvetica in one column and 14-point Times in the other.

**Publishing Partner's** macros let you assign a string of keystrokes to each of the ST's function keys. An effective way to use this feature is to assign commands selecting fonts and typstyles, then—instead of

## "Take two of these and call me in the morning"

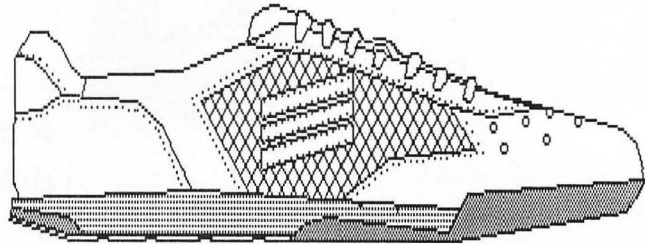

The results are in: walking is an excellent form of exercise. It strengthens your legs, improves your cardiovascular fitness, and simply makes you feel good.

To enjoy the full benefits of walking, you need a comfortable shoe. One designed especially for walking. A shoe like the Everex Trailblazer.

The Everex Trailblazer was designed by orthopedic specialists for optimum support and comfort. Its computer-designed sole offers traction and flexibility. Perforated uppers keep your feet cool.

The Everex Trailblazer also comes with a special feature most walking shoes don't have: a guarantee. If

you're not satisfied with the Everex Trailblazer for any reason, return the shoe within thirty days for a full refund. (See your dealer for details.)

If you plan to walk your way to health, you need a shoe that's as serious as you are. You need Everex Trailblazers.

After all, a walk a day might help keep the doctor away.



Figure 1. — The ad we're trying to get.

manually selecting 18-point bold for each headline, for instance—you can get the job done with a single tap of a key. In effect, you can use macros to create a "style sheet" of standard type styles.

To define a macro, hit ALT and a function key, then press the keystroke for each command. (You can't use the mouse selections.) You're able to see the commands in the macro take place as you define each one, so there's no guesswork.

To use F1 to set up 18-point, bold headlines, press these keys, in order:

(1) ALT-F1. This starts defining the macro.

(2) ALT-F. Brings up the fonts and points dialog box.

(3) ALT-P. Brings up the set points.

(4) ESC. Clears out the point size in the dialog box.

(5) 18 and RETURN. Enters your new size.

(6) RETURN. Leaves the fonts and points dialog box.

(7) ALT-B. Sets boldface.

(8) ALT-F1. Ends macro definition.

Once you've define your macros, select "Save Preferences" from the file menu, to make them readily available the next time you use the program.

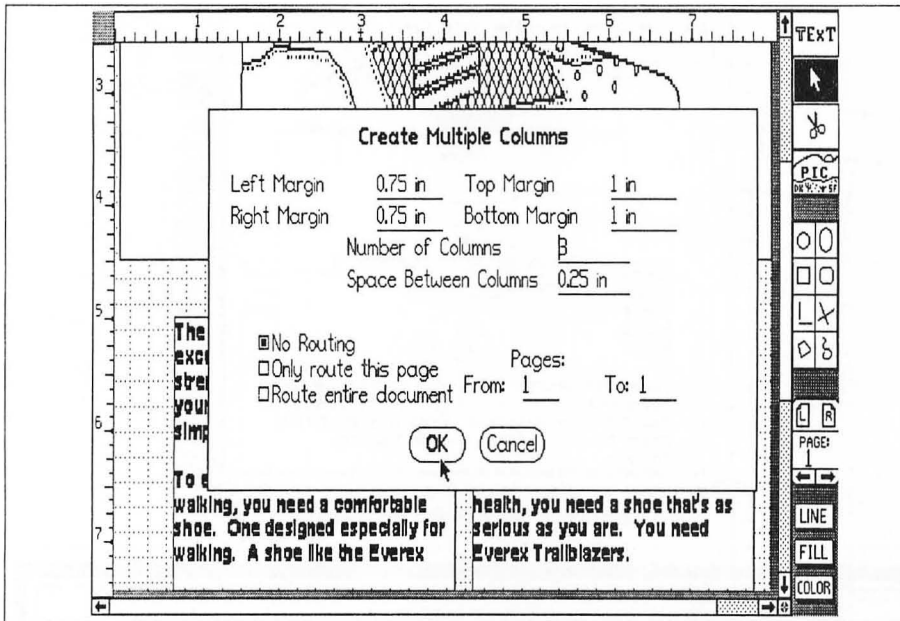

Figure 2. — Setting up the basic layout.

The macro feature has two limitations: you can't include fonts (because you can't select them from the keyboard), and you're limited to ten macros (but that ought to be enough styles for you).

#### Pasting up on-screen.

Pasting up involves taking your copy and artwork and placing them on your pages. **Publishing Partner** works the same way, but without the X-Acto knives and waxing machines used in print shops.

In a print shop, the pasteup artist takes the typeset copy (which usually comes out in one long strip called a *galley*) and places the text in the column. When he comes to the bottom of the column, he cuts the article at that point and starts pasting it in another column. This is called *text routing*.

**Publishing Partner** also provides text routing. To paste up a text file, you click on the column where the text begins and select "Import" from the file menu. If the entire document doesn't fit in the column, you'll see a "+" box in the bottom left corner. Click on the box. The pointer will turn into a small page icon. Move it to the desired column and click. The text then continues in that column.

The "Set Text Routing" command in the create-layout menu can route your article automatically. Select the command and click on the columns to which you want the text routed.

With traditional pasteup, last minute changes can be disastrous. To add a paragraph, you may have to pull off and move

paragraphs onto other pages. When you add copy with **Publishing Partner**, the rest of the text is moved down, even if it continues on another page.

This program's editing features can easily handle last minute changes. Suppose the marketing department changes the product name from "Trailblazer" to "Strider." (Marketing departments are famous for last minute changes like this!) Select "Replace" from the edit menu. In the dialog box, specify *Trailblazer* as the word to be searched and *Strider* as the word to replace it.

#### Picture-perfect graphics.

Pictures are also easy to paste up with **Publishing Partner**. Just cut or copy them from the PIC window and paste them into a column.

Sometimes you have to reduce a picture to fit. In a print shop, you'd have to "stat it down," which means making a photographic copy of it at a smaller size. **Publishing Partner** offers two ways to reduce pictures:

(1) *Drag the picture's handles.* This is the easiest way to fit a picture in a space, but is not recommended for proportional reductions.

(2) *Reduce by a percentage.* The ALT-E command lets you reduce the picture's width and height by a certain percentage. To reduce the picture by half, enter 50 percent for both width and height (see Figure 3).

The cropping tool removes part of a picture by dragging the handles, but doesn't

change the picture's proportions. If you don't want to include the company motto under the logo, you can crop it out. But be careful: once you crop out a piece of the picture, you can't bring it back.

**Publishing Partner** comes with its own set of drawing tools. You can draw circles, lines, rounded boxes or polygons, or create your own shapes freehand. Normally, you'd use these drawing tools for borders, column rules, and the like, but you can create simple artwork with them, too.

#### Special effects.

Once your basic layout is finished, experiment to make it more eye-catching.

Two of **Publishing Partner's** timesteps, tall and wide, can drastically alter your type's appearance. Tall doubles the height, so a 10-point character becomes 20 points tall. This makes the text look thinner and larger, which is ideal for headlines.

Wide doubles the width, so the same 10-point character is 20 points wide. The characters look bolder and fatter.

Another way to change text is by adjusting its spacing. You can alter white space between lines or characters by selecting the "Line/Char Spacing" command from the format menu. Click on the arrows in the dialog box to select the character or line spacing you want. Sample text shows you a fair representation of the look your document will have.

You can use line spacing in several ways. Reduced line spacing fits more text in a small space. In like manner, you can increase line spacing to better fill a large space with a small amount of text, or to make text easier to read.

Character spacing (also called *kerning*) can be used for different effects. And, if you right justify text (straight right margins), it can cut down on any large blank spaces left when a word doesn't fit.

#### Printing it.

The final step in producing your document is printing it. You can send your printout directly to the printer (through the serial or parallel port) or to a disk file. **Publishing Partner** comes with drivers for most of the popular dot-matrix and laser printers.

Before printing, **Publishing Partner** has to calculate the page information. With its new printer drivers, it uses whatever memory space is available for its calculations. Therefore, the more memory you've got, the faster the printing will be.

The disk file options offer you another way to get laser printed quality. The PostScript driver creates an ASCII text file of

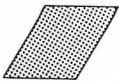

## Publishing, partner! *continued*

PostScript commands. You can send this command file over your modem to your friend's Macintosh or even to a Linotype PostScript-compatible typesetter for PostScript printing.

Print-to-disk files tend to be large. With the PostScript driver, my one-page ad produced a 59K file. The LaserJet driver produced a file that was over 400K!

### Summing up.

Programs like **Publishing Partner** take the drudgery out of a costly and time-consuming process. Work you used to send out to typesetters and pasteup artists can now be done at your own desk. You can make changes immediately. No more sending them to the print shop and hoping they're done correctly. With the tools **Publishing Partner** offers, you can create attractive, camera-ready material. //

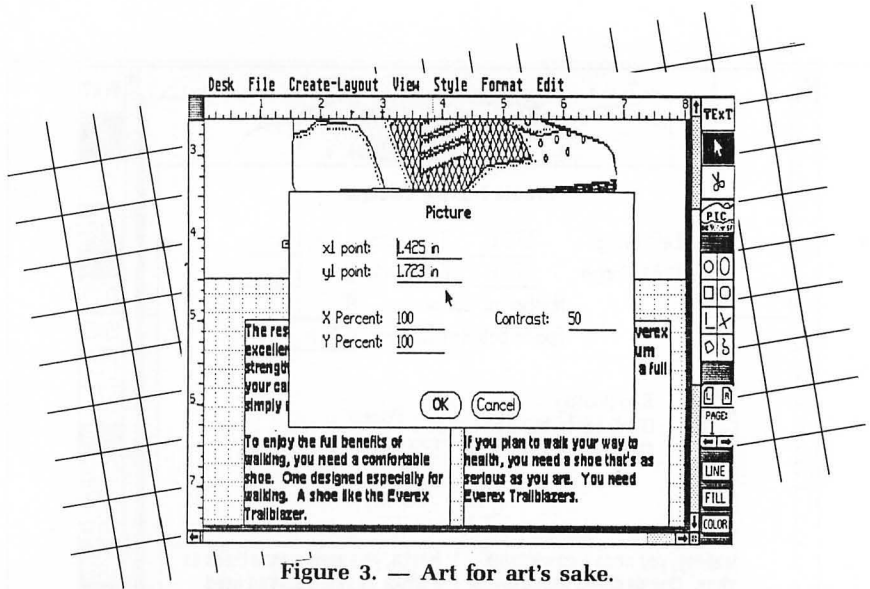
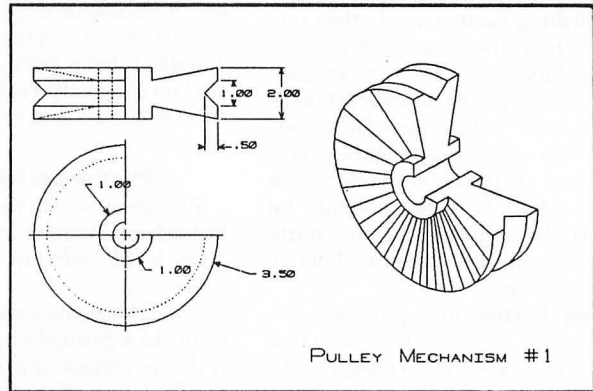
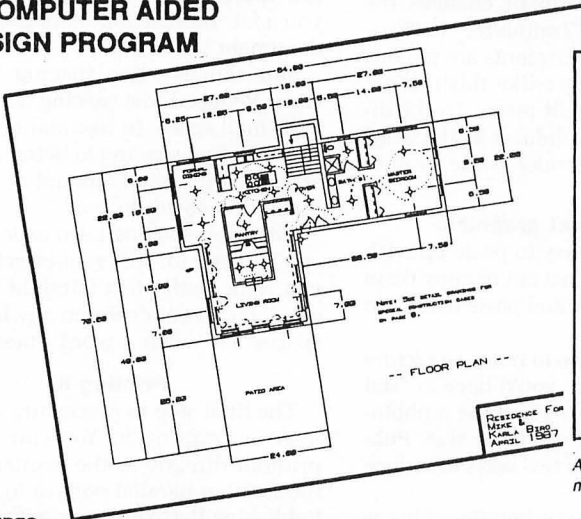

Figure 3. — Art for art's sake.

# ATHENA II

## A COMPUTER AIDED DESIGN PROGRAM



All of Athena II's commands are well documented, in a large well organized manual. A wealth of commands make any task a breeze.

### FEATURES:

Auto Dimensioning,  
B-Splines;  
256 Layers, (16 Colors)  
**Circles;** (Radius, Diameter, & Three Point),  
Arcs, Ellipse, Elliptical Arcs, & Fillets.  
**Lines;** Horizontal, Vertical, Parallel,  
Perpendicular, Tangential, Line at an Angle,  
Line between Lines, Rectangles, Line  
Tangent to Two Circles, Etc.  
**Transformation;** Move, Copy, Rotate,  
Scale, Mirror, Trim (Adjusts any line or circle

so that it will exactly intersect with any given line or circle. No magnifying an area to see if your lines exactly meet!)  
**Parts;** Create "Parts" from an existing drawing, and save them. Load "Parts" from libraries, and place them, anywhere, on any drawing.  
**Isometrics;** Semi-automatically transform existing drawings into an Isometric View.  
**Plus;** Grids, Fills, Erase, Text, Points, Files, Information and full Zooming capabilities.

A professional, full color, Two-Dimensional Computer Aided Design program, incorporating an ease of use seldom seen in CAD programs.

**\$99.95**  
Suggested Retail

**iliad**  
SOFTWARE, INC.

Atari 520ST, 1040ST, SF-354, and SF-314  
are registered trademarks of Atari Inc.  
GDOS is a registered trademark of Illad  
Software, Inc.

495 West 920 North  
Orem, Utah 84057  
Tel: 801-226-3270

CIRCLE #106 ON READER SERVICE CARD

# Floyd the Droid on the Run

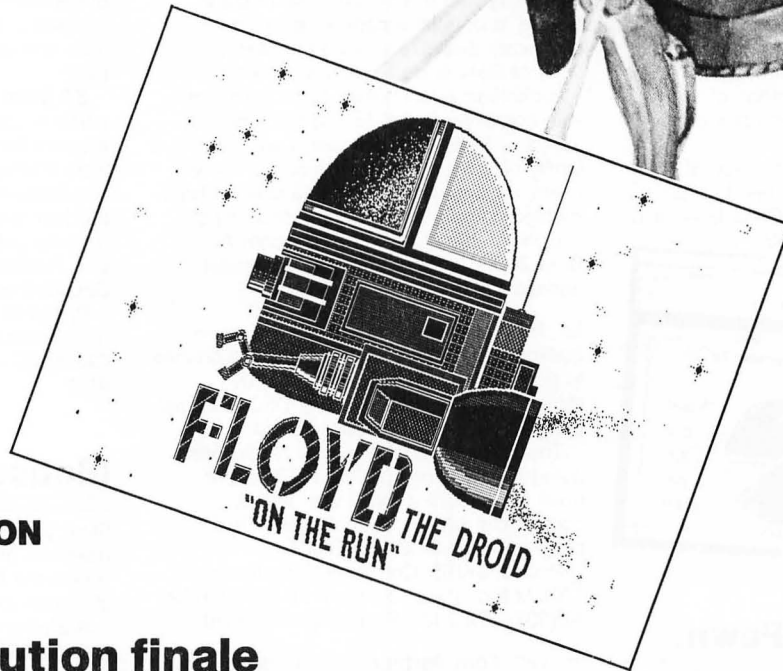
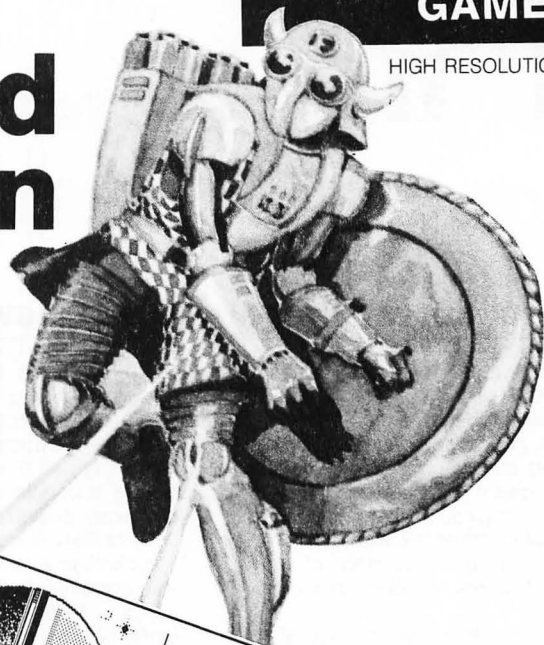

## A SPECIAL INCLUSION

## The high-resolution finale to our prize-winning ST program.

by Paul Lay

As promised last issue, here's the monochrome version of *Floyd the Droid on the Run*. Once again, since the program is too long for these pages, the listings are on the magazine's disk version and on the Atari Users' Group SIG on Delphi.

The rules and play are the same as for the low-resolution version published last month.

### Using the program.

**Floyd** can be loaded by clicking on the DROIDHI.PRG icon. On loading, an **ANALOG** logo screen will fade in, followed by the title screen. The program will then be loaded and executed within a few seconds.

Keyboard controls are used for various levels and functions of the game. Keys F1 through F6 will begin the game, at levels 1, 10, 20, 30, 40 or 50. Hitting **C** lets you continue from the previous level. Press **D** if you want to see a crazy demo. The **V** key toggles volume on or off, while **P** dumps

the screen to your printer. To abort a game, press **ESCAPE**, and use the **SPACE BAR** to pause or resume the game.

A joystick in the second port is used to control the droid. Moving the joystick in any direction moves **Floyd** in that direction. Pressing the trigger fires a photon in the direction of the joystick. Four photons can be fired at once.

If your score is high enough, you'll be able to enter your name in the high-score table. All alphanumeric characters are available, plus the **SPACE** and **BACKSPACE**. To terminate the entry of a name, press **RETURN**.

Enjoy the game. //

*Paul Lay studied Computer Science at Imperial College in London. He's owned his Atari 800 for about four years, and has had several programs published in various English magazines (Personal Computer World, Page 6 Magazine and Atari User). He has also written an arcade game, Sprong, released by Bignose Software in the U.K.*

## Financial spreadsheet.

**MasterPlan** from ISD, the company behind VIP Professional and STAccounts, is a low-cost spreadsheet that uses the ST's GEM environment, mouse and graphics.

Worksheets and graphics can be created with a slant toward financial productivity. Date, financial, logical, mathematical, special and statistical functions are all at your fingertips, as well as a wide range of spreadsheet features. Works in color or monochrome.

For additional information, contact ISD Marketing, Inc., 2651 John Street, Unit 3, Markham, Ontario L3R 2W5, Canada — (416) 479-1880. Reader Service #132.

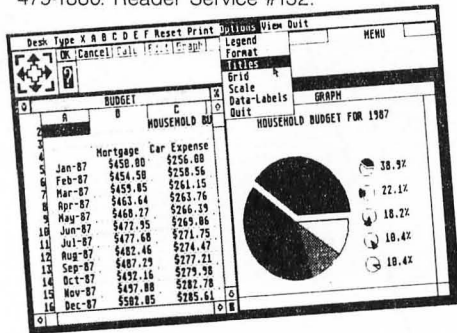

## Sequel to The Pawn.

**The Guild of Thieves**, Rainbird's follow-up to their very successful graphics adventure The Pawn, is now available for the ST (as well as for the Atari 8-bits). This illustrated adventure once again takes place in the mythical kingdom of Kerovnia—though things are a bit different now.

According to the authors, this new title contains witty dialog, improved graphics, wry humor and challenging puzzles, plus a humorous 40-page novella, dice, Bank of Kerovnia credit card, and much more.

Retails for \$39.95, from Firebird Licensees, Inc., P.O. Box 49, Ramsey, NJ 07446. Reader Service #108.

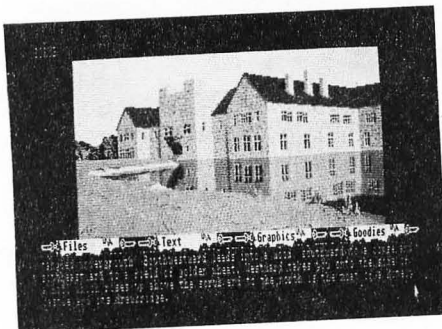

## Other news.

☑ Three-Sixty is Thomas Frisina's new company (he was President of Accolade and, earlier, of Androbot). The firm's goal: distinctive products for personal computers, beginning with this fall's release of **Dark Castle**, a popular arcade-style game previously available only on the Mac.

Three-Sixty is developing a proven "psychological technology to be introduced—in computer format for the first time—in January, 1988. This technology will result in a family of products for business and home users, dealing with solutions to stress-related problems and interpersonal relationships."

Contact them at: 2105 S. Bascom Ave., Suite 290, Campbell, CA 95008. Reader Service #109.

☑ Tired of that dull gray or bright green background? **Easel/ST** gives you the chance to personalize your GEM desktop, by replacing that screen with any DEGAS-format picture you choose as background.

This program operates in all resolutions, automatically runs from the AUTO folder, does not require a menu slot, and is compatible with all ST computers. The program also works with GDOS.

Priced: \$19.95. Computer Fenestrations, 1701 Missouri Ave., Sanford, FL 32771-9722 — (305) 322-2002. Reader Service #110.

☑ With **Font Partner**, you can design your own screen and printer fonts for use with SoftLogik's desktop publishing program, Publishing Partner.

An easy-to-use printer font editor, screen font editor and file manager are all included in this package. **Font Partner** sells for \$24.95. Interactive MicroSystems, P.O. Box 1188, Canyon Country, CA 91351-2600 — (805) 298-7357. Reader Service #111.

☑ **K-Roget** from the British firm, Kuma, is a thesaurus including over 150,000 words and phrases. It's compatible with GEM-based software such as word processors, etc., since it operates as a desk accessory.

Available from ScanAm, P.O. Box 1145, Ridgewood, NJ 07451 — (201) 445-5260. Reader Service #112.

## Scan the world.

A new image scanner, **ST Scan**, combines the Cannon IX-12 with Navarone's own high-speed cartridge port interface, cables and software, to provide the user with a method of transferring hardcopy into the ST. Scanning is possible at 75, 150, 200 and 300 dots per inch, and at speeds up to 12 seconds per page.

**ST Scan** will operate on a 520ST, but performs much better on a 1040ST, which allows a full page to be read at 200 dots per inch. Photographs and illustrations can be converted in as many as 32 gray levels. This product is ideal for transferring images into desktop publishing work, and is compatible with Publishing Partner, Easy-Draw and DEGAS Elite, among others.

Priced at \$1239.95. Navarone Industries, Inc., 21109 Longeway Road, Suite C, Sonoma, CA 95370 — (209) 533-8349. Reader Service #113.

## Mousepouch . . .

Store your ST's mouse—or up to eight disks—in one of these. Made of a vinyl suede, the **Mousepouch** attaches to the side of a desk or monitor with supplied velcro.

Available in natural tan or metallic trim-light grey for \$5.95. From H&H Enterprises, Box 2672, Corona, CA 91718 (714) 737-1376. Reader Service #114.

## . . .and cleaner.

**Mouse Cleaner 360** is a low-cost kit which can be used to clean the tracking rollers inside your mouse. Complete with a velcro-covered scrubber ball, scrubber board, lint free chamois cloth and cleaning solution.

The kit retails for \$16.95. Ergotron, Inc., 1621 East 79th Street, Minneapolis, MN 55420. Reader Service #115.

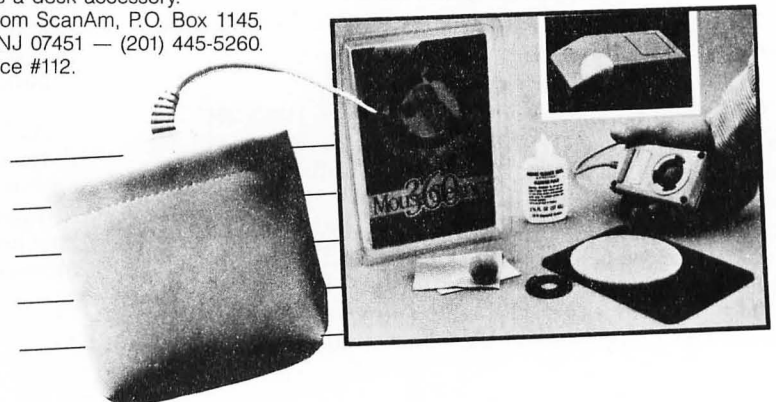



## CAV system.

**Dxmate** is a Computer Aided Voice (CAV) system, which includes a voice editor, voice generator sequencer, and voice and bank librarian.

**Dxmate** eases the complexity of programming digital FM synthesizers, by displaying all parameters of a voice on the high-resolution screen at once. This package makes full use of the mouse and GEM features, including drop-down menus, forms, slider bars and windows. The software currently works with the Yamaha DX21, DX27, or DX100 synthesizers and an ST with a monochrome monitor.

Retail is \$99.00. Synchro-Systems, P.O. Box

3093, Saskatoon, Saskatchewan S7K 3S9, Canada. Reader Service #116.

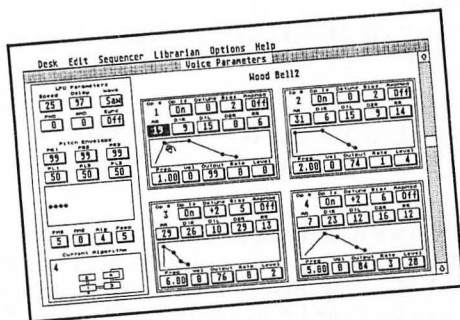

## 3D wireframe modeller.

Following its popular Easy-Draw 2.0 and LabelMaster, Migraph has announced **M/CADD**, a two-module software package.

2D Drawing Composer lets users create 2-dimensional wireframe drawings with a variety of commands. Powerful features give the ability to create a graphics database with line styles, multiple drawing scales, and more. Users can add text, dimensions or figures to drawings, and view from a wide range of functions including zoom. Special features are vector variables and functions, line functions and plane functions, to name but a few. Extensive file handling and user interfacing add to the program's ease.

The second part of this package is 3D Wireframe Modeller, with features and functions similar to the 2D package. Design your own 3D image, then load that image (from either the 2D or 3D module) into the Easy-Draw program (version 2.0 or greater), and add patterns and text.

Both programs contain far too many features to list here; contact Migraph for details. Cost is \$299.95 each—or, as a special until September 20, 1987, \$499.95 for both. Migraph, Inc., 720 South 333rd Street, Suite 201, Federal Way, WA 98003 — (206) 838-4677. Reader Service #117.

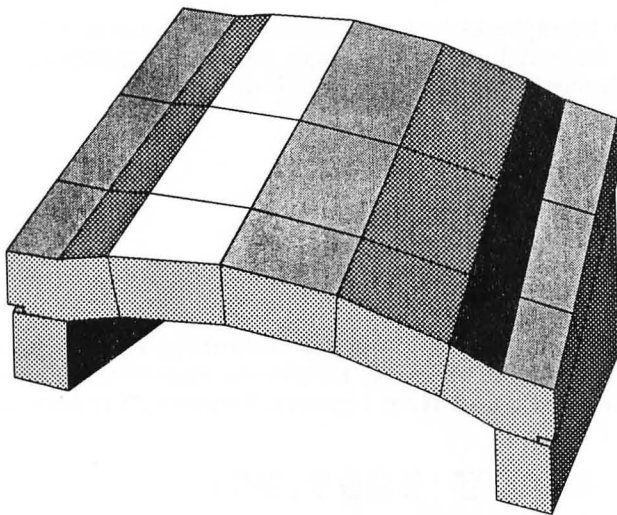

**M/CADD** — A new dimension in wireframe modellers.

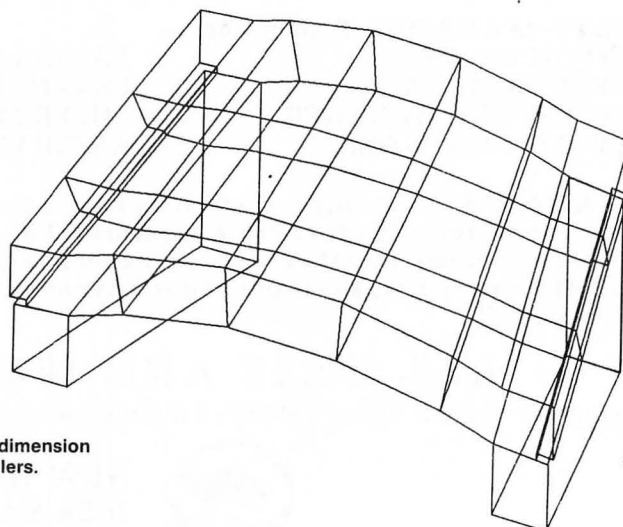

## Arcade action.

**Orion's Run** offers colorful scrolling in this Xevious-like shoot-'em-up. Zoom over the terrain, blasting alien sky objects and dropping bombs on enemy targets—aiming carefully for the fuel depots to fill your own tanks. Also available in a monochrome version, both for \$39.95. And, for \$19.95, you can obtain the C source code listing.

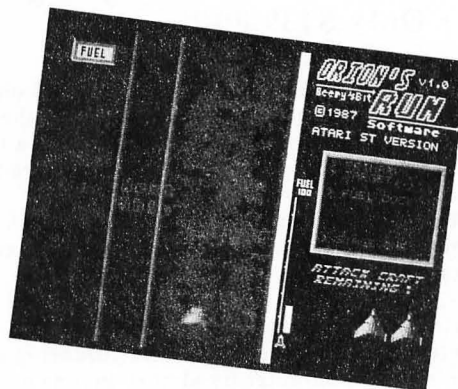

**ColorBurst 3000** gives your ST over 3000 colors, with 1600 on the screen at once. Pull-down menus with on-screen manual make the program easy to use. Fully compatible with Neo-Chrome and DEGAS pictures. Runs in all resolutions and is selling for \$59.95.

Also available is the **ColorBurst Developers Kit**, which permits programmers to add **ColorBurst** screens to their own programs using the driver routines in this package. Price is \$19.95.

All of these products are from Beery's Bit Software, 8174 Century Circle East, Suite 8, Indianapolis, IN 46260 — (312) 872-8622. Reader Service #118.

# 2 NEW PRODUCT INTRODUCTIONS FROM New World Software

## 2/4 Megabyte upgrade for your 520/1040ST's ONLY \$139.00!!

New World Software is proud to introduce a 2/4 megabyte upgrade kit for your 520 or 1040ST series computers. This upgrade was designed for New World Software by Nilford Laboratories, Inc. of San Jose, California and will allow your 520 or 1040S's memory to be internally increased to 2.5 megabytes or a full 4 megabytes of RAM!!

- Great for desktop publishing!!
- Allow your Atari laser printer to print full page text and graphics!!
- Create very large RAMdisks!!
- Create very large spreadsheets!!
- Great for compiling large programs in RAMdisk!!
- Only \$139.00!!

The board uses only one-megabit RAM chips. The board can be stuffed with 16 one-megabit chips, yielding 2.5 megabytes of total memory (the other .5 meg comes from the RAM already inside your computer). The board can also be stuffed with an additional 16 one-megabit chips, which gives the user a total of 4 megabytes of RAM. Assuming that you can get one-megabit RAM chips for \$22 each, then a complete 2.5 megabyte upgrade can be done for under \$500!! (16 chips \* \$22 each + \$139 for the board = \$491).

Although the board does not come with any RAM chips, the one-megabit chips can be purchased from most electronics distributors, electronics stores, and are also available directly from New World Software (call 408-866-5003 for the latest pricing information).

Installation is very simple. The four DIP connectors supplied allow quick and easy installation by simply snapping the DIP connectors over existing chips, and soldering only 5 wires. Installation should be done by someone with technical skills, but can be done in under 10 minutes by almost anyone experienced with electronics. No need to remove the MMU chip and risk damaging both the MMU chip and the socket its in. The memory board draws its power from the ST, so the ST should not power any additional peripherals which consume large amounts of power.

The board comes complete with sockets for up to 4 megabytes of memory, all necessary connectors, and instructions.

## MULTI-MANAGER<sup>TM</sup>

*The best point-of-sales accounting program you can buy for your business.*

**MULTI-MANAGER** is a powerful, sophisticated system for management of your small to medium sized retail and/or wholesale business. Why **Multi-Manager**? Not only does it help you manage multiple aspects of your business, but it also helps you manage multiple store locations from one Super Manager location.

Here's **MULTI-MANAGER'S** main menu:

INVOICE MANAGER	PAYROLL MANAGER
VENDOR MANAGER	EXTENDED MANAGER
INVENTORY MANAGER	SUPER MANAGER
SYSTEM MANAGER	ARCHIVE MANAGER

**MULTI-MANAGER** is the only program of its kind that allows you to:  
Transfer inventory items to other store locations. Put spiffs or commissions on any inventory item. Package multiple inventory items together as one part number, Generate Sales reports, Employee reports, Inventory reports, Hot Mover reports, Re-order reports, Vendor reports, Returned item reports, Layaway reports, plus many other reports!!

### ALL THIS AND MORE ONLY \$299.95!

System requirements are: 520 or 1040ST, 2 double-sided floppy drives, or a hard disk, color, or monochrome monitor.



NEW WORLD SOFTWARE  
1654 SAN TOMAS AQUINO ROAD  
SAN JOSE, CA. 95130 (408)866-5003

# AutoTransfer

Use this utility with RAMmer  
to get a RAMdisk set up in no time.

by Maloney

By now, you have probably discovered the advantages of placing a RAMdisk into an AUTO folder. Unfortunately, there's still the tedium of manually transferring the desired files, so that the computer awakens with the RAMdisk directory window displaying the files you want to use.

I lay no claims to genius or to overwhelming insight. There are commercial and public domain programs that accomplish this. The problem is that they require you to enter the filenames to be automatically transferred into a special file. Plus you have to total up the file sizes, so you don't exceed the capacity of your RAMdisk. Whatever happened to point-and-click?

### A better way.

GEMDOS is MS-DOS (the DOS used by the IBM PC and its clones) rewritten by DRI for the MC68000. Whereas TOS doesn't provide a command-line interface to it, a program can access all of its functions. It suddenly dawned on me that if I were to create a folder, then drag files into it, I could make GEMDOS transfer those files to the RAMdisk on power-up. The RAMdisk and the **AutoTransfer** program go into the AUTO folder; the files to be automatically transferred go into a folder I call BOOT.

### Getting started.

The first thing to do is establish the identifier of the drive containing the BOOT folder. The GEMDOS call, SETDRV (determine drive number—\$0E), does this. (Zero is drive A, one is drive B, etc.) By the way, the source drive can be a hard disk—more on this later.

Remember, the files will be in the BOOT folder. A folder is GEM's way of graphically representing a subdirectory. Therefore, we use CHDIR (change pathname—\$3B) to tell GEMDOS that the files to be transferred are in the subdirectory called BOOT. But how can we access the files if we don't know their names?

### The Atchison, Topeka and the DTA.

GEMDOS uses a special 44-byte buffer called the Disk Transfer Address—DTA for short. The top 14 bytes hold the name of the file being accessed by disk commands. We call GETDTA (\$1A) to tell GEMDOS where this buffer is located.

The ST uses filenames of up to eight characters, followed by a period, completed by an extension of up to three characters. Using the asterisk as a wild card, a filename of \*.\* means "any name in this (sub)directory."

This is where GEMDOS really makes things easy for us. Using SFIRST (Search for the first file of a certain name—\$4E), we locate the first file in the BOOT folder. OPEN (\$3D) prepares us to READ (\$3F) the file into a buffer.

Now we must transfer the contents of the buffer to the RAMdisk. Re-invoking SETDRV accesses the RAMdisk. We cannot follow it with OPEN, however. OPEN only works with files that already exist. Instead, we use CREATE (\$3C), which also automatically opens the file. As you probably already suspected, we then use WRITE (\$40) to move the contents of the buffer to the RAMdisk.

If there were only one file in the BOOT folder, then we would be finished. Chances are, though, that we have to transfer multiple files. Again, GEMDOS comes to the rescue. SNEXT (\$4F) searches for the next file of the same name (in our case, \*.\*). We then continue through the loop until all the files have been transferred.

The final GEMDOS call is TERM (terminate the program and free all the memory used—\$00). Control then passes to the next program—normally the desktop—and the computer has done our work for us.

### Installation and use.

To accommodate a wide variety of disk drive configurations, I've provided a BASIC loader. It first prompts you for the source drive—this is the drive the BOOT folder resides in. It then asks for the drive identifier of your RAMdisk. The name of the machine-language program created by the



loader contains these two parameters. For example, XFRBT\_\_AD.PRG transfers the files from the BOOT folder on drive A to the RAMdisk in drive D.

It's been reported by at least two normally reputable publications that .PRG files in an AUTO folder execute in *alphabetical* order; this is *not* the case. They execute in the order they were entered into the subdirectory. In short, it's necessary that you move your RAMdisk into the AUTO folder ahead of XFRBT\_\_XX.PRG.

When I use 1st Word, I create an AUTO folder, then copy my print spooler, my RAMdisk, and finally XFRBT\_\_XX.PRG, in that order. Always start with a fresh AUTO folder, and never "edit" it by deleting and copying. If you do so, you can't be sure what order the files will follow in the subdirectory.

### Between XFRBT\_\_XX.PRG and a hard disk.

While I was developing this program, a friend of mine with a hard disk volunteered to "beta-test" it on his system. He's partitioned his drive into four *logical* drives: C, D, E and F. He uses drive F for word processing, so he placed his 1st Word files into a BOOT folder on that drive. He then created an AUTO folder on a floppy disk. When he powers up with this disk in drive A, his 1st Word files appear in the RAMdisk directory for drive G.

The advantages are that the boot-up operation is much faster than with a floppy, and, during subsequent file operations, he saves wear and tear on his expensive hard disk. He also uses the floppy to back up his .DOC files directly from the RAMdisk.

### Accessories are a crime.

If your RAMdisk is configured as a desk accessory, placing XFRBT\_\_XX into an AUTO folder won't work. The reason is that TOS executes .PRG files in the AUTO folder before it loads accessories. When the program executes, there's no destination drive present; SETDRV returns with an error condition, and the program terminates. It also leaves you stuck in the BOOT subdirectory on your source drive.

You can still use XFRBT\_\_XX. Just double-click on its icon after boot-up is complete. The only thing you lose is the auto feature. //

Listing 1.  
ST BASIC listing.

```
100 FULLW 2: CLEARW 2: LINE INPUT: "ENTER
SOURCE DRIVE NUMBER (A-F): "; SD$
110 IF SD$ <"A" OR SD$ >"F" OR LEN(SD$) <
>1 THEN 100
120 LINE INPUT: "ENTER DESTINATION (RAM
DISK) DRIVE NUMBER (C-P): "; DD$
130 IF DD$ <"C" OR DD$ >"P" OR LEN(DD$) <
>1 THEN 120
140 OPEN "R", #1, "A:XFRBT_" + SD$ + DD$ + ".P
RG", 2
150 FIELD #1, 2 AS D$: FOR I=1 TO 179: RE
AD A$
160 B$=CHR$(VAL("&H"+LEFT$(A$, 2))) + CHR
$(VAL("&H"+RIGHT$(A$, 2)))
170 LSET D$=B$: PUT #1, I: NEXT
180 B$=CHR$(0) + CHR$(ASC(SD$) - 65): LSET
D$=B$: PUT #1, 133
190 B$=CHR$(0) + CHR$(ASC(DD$) - 65): LSET
D$=B$: PUT #1, 90: CLOSE #1: END
```

```
200 DATA 601A, 0000, 013C, 0000, 0000, 0000
, 0000, 0000
210 DATA 0000, 0000, 0000, 0000, 0000, 0000, 0000, 0000
, 6100, 00E8
220 DATA 4A40, 6B00, 00DC, 4879, 0000, 0104
, 3F3C, 003B
230 DATA 4E41, 5C8F, 4A40, 6600, 00C8, 4879
, 0000, 0110
240 DATA 3F3C, 001A, 4E41, 5C8F, 3F3C, 0000
, 4879, 0000
250 DATA 0109, 3F3C, 004E, 4E41, 508F, 4A40
, 6600, 00A2
260 DATA 6012, 6100, 00A2, 3F3C, 004F, 4E41
, 548F, 4A40
270 DATA 6600, 008E, 3F3C, 0000, 4879, 0000
, 012E, 3F3C
280 DATA 003D, 4E41, 508F, 3E00, 4A40, 6B74
, 4879, 0000
290 DATA 013C, 2F39, 0000, 012A, 3F07, 3F3C
, 003F, 4E41
300 DATA DFFC, 0000, 000C, 4A80, 6B56, 6168
, 4A40, 6650
310 DATA 3F3C, 0003, 3F3C, 000E, 4E41, 588F
, 4A40, 6B40
320 DATA 3F3C, 0000, 4879, 0000, 012E, 3F3C
, 003C, 4E41
330 DATA 508F, 3E00, 4A40, 6B28, 4879, 0000
, 013C, 2F39
340 DATA 0000, 012A, 3F07, 3F3C, 0040, 4E41
, DFFC, 0000
350 DATA 000C, 4A80, 6B0A, 611C, 4A40, 6604
, 6000, FF64
360 DATA 3F3C, 0000, 4E41, 3F3C, 0000, 3F3C
, 000E, 4E41
370 DATA 588F, 4E75, 3F07, 3F3C, 003E, 4E41
, 588F, 4E75
380 DATA 424F, 4F54, 002A, 2E2A, 0000, 0000
, 0000, 0000
390 DATA 0000, 0000, 0000, 0000, 0000, 0000
, 0000, 0000
400 DATA 0000, 0000, 0000, 0000, 0000, 0000
, 0000, 0000
410 DATA 0000, 0000, 0000, 0000, 0000, 000C
, 1412, 2C14
420 DATA 0632, 1406, 0000
```

ST CHECKSUM DATA.  
(see page 59)

```
100 data 86, 498, 874, 415, 964, 815
, 899, 412, 107, 655, 5725
200 data 815, 793, 122, 77, 144, 134
, 102, 66, 165, 132, 2550
300 data 210, 242, 109, 101, 130, 14
8, 189, 282, 17, 733, 2161
400 data 708, 834, 442, 1984
```

Listing 2.  
Assembly listing.

```
START      BSR      SETDRVA
            TST.W  D0          ; DID ERROR OCCUR?
            BMI   EXIT       ; IF SO TAKE BRANCH

CHDIR      PEA     PATH      ; ADDRESS OF PATH NAME
            MOVE.W #3B, -(SP) ; CHANGE DIRECTORY
            TRAP  #1         ; GEMDOS
            ADD.L  #6, SP     ; POP STACK
            TST.W  D0          ; DID ERROR OCCUR?
            BNE   EXIT       ; IF SO TAKE BRANCH

GETDTA     PEA     DTA       ; ADDRESS OF DTA BUFFER
            MOVE.W #51A, -(SP) ; SET DISK TRANSFER ADDRESS
            TRAP  #1         ; GEMDOS
```

```

ADDQ.L #6, SP ;POP STACK
SFIRST MOVE.W #0, -(SP) ;NORMAL (R/W) FILE
      PEA FILENAME ;ADDRESS OF FILENAME
      MOVE.W #54E, -(SP) ;SEARCH FOR FIRST FILE
      TRAP #1 ;GEMDOS
      ADDQ.L #8, SP ;POP STACK
      TST.W D0 ;DID ERROR OCCUR?
      BNE EXIT ;IF SO TAKE BRANCH

BRA.S OPEN
LOOP BSR SETDRVA
SNEXT MOVE.W #54F, -(SP) ;SEARCH FOR NEXT FILE
      TRAP #1 ;GEMDOS
      ADDQ.L #2, SP ;POP STACK
      TST.W D0 ;DID ERROR OCCUR?
      BNE EXIT ;IF SO, TAKE BRANCH

OPEN MOVE.W #0, -(SP) ;FILE CAN BE READ ONLY
      PEA NAME ;ADDR OF CURRENT FILE NAME
      MOVE.W #53D, -(SP) ;OPEN
      TRAP #1 ;GEMDOS
      ADDQ.L #8, SP ;POP STACK
      MOVE.W D0, D7 ;STORE HANDLE
      TST.W D0 ;DID ERROR OCCUR?
      BNE.S EXIT ;IF SO TAKE BRANCH

READ PEA BUFFER ;ADDRESS OF DATA BUFFER
      MOVE.L SIZE, -(SP) ;SIZE OF CURRENT FILE
      MOVE.W D7, -(SP) ;HANDLE
      MOVE.W #53F, -(SP) ;READ
      TRAP #1 ;GEMDOS
      ADD.L #12, SP ;POP STACK
      TST.L D0 ;DID ERROR OCCUR?
      BNE.S EXIT ;IF SO TAKE BRANCH

      BSR.S CLOSE
      TST.W D0 ;DID ERROR OCCUR?
      BNE.S EXIT ;IF SO TAKE BRANCH

SETDRUD MOVE.W #3, -(SP) ;DRIVE D
      MOVE.W #50E, -(SP) ;SET CURRENT DRIVE
      TRAP #1 ;GEMDOS
      ADDQ.L #4, SP ;POP STACK
      TST.W D0 ;DID ERROR OCCUR?
      BNE.S EXIT ;IF SO TAKE BRANCH

CREATE MOVE.W #0, -(SP) ;NORMAL (R/W) FILE
      PEA NAME ;ADDRESS OF "*.*)"
      MOVE.W #53C, -(SP) ;CREATE
      TRAP #1 ;GEMDOS
      ADDQ.L #8, SP ;POP STACK
      MOVE.W D0, D7 ;STORE HANDLE
      TST.W D0 ;DID ERROR OCCUR?
      BNE.S EXIT ;IF SO TAKE BRANCH

WRITE PEA BUFFER ;ADDRESS OF DATA BUFFER
      MOVE.L SIZE, -(SP) ;SIZE OF FILE
      MOVE.W D7, -(SP) ;HANDLE
      MOVE.W #540, -(SP) ;WRITE
      TRAP #1 ;GEMDOS
      ADD.L #12, SP ;POP STACK
      TST.L D0 ;DID ERROR OCCUR?
      BNE.S EXIT ;IF SO TAKE BRANCH

      BSR.S CLOSE
      TST.W D0 ;DID ERROR OCCUR?
      BNE.S EXIT ;IF SO TAKE BRANCH

BRA LOOP ;CONTINUE UNTIL DONE

EXIT MOVE.W #50, -(SP) ;TERM
      TRAP #1 ;GEMDOS

SETDRVA MOVE.W #0, -(SP) ;DRIVE A
      MOVE.W #50E, -(SP) ;SET CURRENT DRIVE
      TRAP #1 ;GEMDOS
      ADDQ.L #4, SP ;POP STACK

CLOSE MOVE.W D7, -(SP) ;HANDLE
      MOVE.W #53E, -(SP) ;CLOSE
      TRAP #1 ;GEMDOS
      ADDQ.L #4, SP ;POP STACK
      RTS

PATH DATA
      DC.B 'BOOT', 0

FILENAME DC.B '*.*', 0

      BSS
      DS.W 13
      SIZE DS.W 2
      NAME DS.W 7

BUFFER DS.W 0

END

```



# ALIANTS

**DESPERATE BATTLE  
FOR EARTH**

**STRATEGY  
ACTION  
SPACE  
BATTLES  
FIRST  
PERSON  
ANIMATED GRAPHICS**

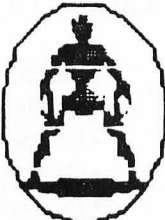

WANTED

Join the Allied Rebel Fleet. Fight the dreaded Aliant army, the force that holds the Earth in chains. Their power crystals are on the way. Once they arrive, Humanity is doomed. Top-notch bullet pilots are needed to stop them. Lead the mission to free the Earth. Only the bravest need apply.

PROGRAM PARAMETERS	
LANGUAGE .....	MACHINE
NUMBER OF PLAYERS .....	1
AVERAGE COMPLETION .....	90 MIN.
AGE GROUP .....	10 TO ADULT
CLASS .....	STRATEGY ACTION
SOUND .....	YES
ANIMATED GRAPHICS .....	YES
EQUIPMENT .....	JOYSTICK

SYSTEMS  
AVAILABLE  
ATARI ST  
ATARI  
C-64/128



DO YOU HAVE WHAT IT TAKES?  
EXCLUSIVELY DISTRIBUTED BY

TDC DISTRIBUTORS INC.  
3331 BARTLETT BOULEVARD  
ORLANDO, FLORIDA 32811

**ORDER NOW**

305-423-1987  
CIRCLE #120 ON READER SERVICE CARD

STARSOFT DEVELOPMENT LABORATORIES

## THE FONT FACTORY™

Specializing in  
Quality products  
for use with  
Publishing Partner™

### FONTS

*Printer fonts & screen fonts for high & medium rez.*

- Disk #1 : Avant Garde, Courier, Calligraphy
- Disk #2 : Times, Helvetica Narrow, 16 Bit
- Disk #3 : Chancery, Bookman, Chicago
- Disk #4 : Palatino, Schoolbook, Computer
- Disk #5 : Dingbats, Symbols, 8 Bit
- Disk #6 : Complete set of 11 LaserWriter fonts

**\$29.95 per disk**

---

### CLIP ART

*Over 100 QUALITY pictures on each disk.*

- Disk #1 : Computer, Office, Newsletter, School, Seasons
- Disk #2 : Business, Sports, Holiday, Relig., Computer
- Disk #3 : Travel, Medicine, America, Music, Personal
- Disk #4 : Food, Borders, Western, Animals, School
- Disk #5 : Tools, Pirates, Party, Hands, Transportation

**\$19.95 per disk**

---

*Coming soon: Color clip art for DEGAS™ and Animator™. Write for information!*

The Font Factory P.O. Box 17422, Phoenix, AZ 85011  
Dealer inquiries welcome.

Please include \$2.50 per order for postage & handling.

CIRCLE #121 ON READER SERVICE CARD

# "Don't even think about another C compiler"

- Mike Fleischman, ANTIC: The Atari Resource, Sept. 1986

Megamax Professional C Development System For The Atari ST  
Rated #1 C compiler by ANTIC, Computel's Atari ST, and Start: The ST Quarterly

- Full Kernighan and Ritchie implementation
- Single pass compilation
- Full access to GEM routines
- Graphical shell
- Intelligent Linker produces efficient native code
- Extensive documentation
- Disassembler
- C programmer's editor
- Code improver
- Developer support included
- Resource construction program
- Create desk accessories

- In-line assembly and structure passing
- Object file librarian
- Six times faster than Atari Development Package
- Develop on single drive 520 ST

- The compiler chosen for development by:

Batteries Included

EPYX™

FTL Games

MichTron

Supra Corp.

\$199.95

• Mastercard, VISA,  
American Express & C.O.D.

## Megamax Development Systems

Megamax, Inc. • Box 851521  
Richardson, TX 75085  
(214) 987-4931

CIRCLE #122 ON READER SERVICE CARD

# Attention Programmers!

**ST-Log** is interested in programs, articles, and software review submissions dealing with the Atari home computers. If you feel that you can write as well as you can program, then submit those articles and reviews that have been floating around in your head, awaiting publication. This is your opportunity to share your knowledge with the growing family of Atari computer owners.

All submissions for publication, both program listings and text, should be provided in printed and magnetic form. Typed or printed copy of text is mandatory and should be in upper and lower case with double spacing. By submitting articles to **ST-Log**, authors acknowledge that such materials, upon acceptance for publication, become the exclusive property of **ST-Log**. If not accepted for publication, the articles and/or programs will remain the property of the author. If submissions are to be returned, please supply a self-addressed, stamped envelope. All submissions of any kind must be accompanied by the author's full address and telephone number.

Send programs to:  
Editor, **ST-Log**  
P.O. Box 23, Worcester, MA 01603.

# Utilities for the 520ST



**A look at most of what's out to make your ST life easier.**

by Arthur Leyenberger

Utility programs are an important software category. The right utility can mean the difference between making your Atari easy to use or spending hours to accomplish a particular task. These kinds of programs run the gamut from file format converters to spelling checkers.

Now that the ST has been available for well over a year, there's an increasing number of utility programs . . . so many, in fact, that this article had to be finished without including the latest ones. Not every utility program ever made will be mentioned here. My apologies if I left out your favorite, but those listed here are representative of good, useful programs.

Issue 39 of **ANALOG Computing**, back in February 1986, contained a first look at utility programs. Products mentioned in that article included: Micro C-Shell, M-Disk, MichTron Utilities, Soft Spool, Mi-Copy, H&D Tool Box, Hippo Spell, Hippo's DUST and Hippo Ramdisk. Those products will not be covered here, so you may want to check out that magazine for information on them.

As most of us know by now, the Atari 520ST uses what's called the "desktop metaphor." This means that the computer screen resembles something you are already familiar with: a desktop. When TOS is booted up, two disk icons appear as file drawers, and a trash can icon is available to "throw out" unused files. This all comes together by means of the mouse.

Files are pointed at, dragged, clicked on, and otherwise manipulated by rolling the mouse around your real desk.

This is wonderful for the first-time user, who doesn't want to be burdened by learning a lot of difficult-to-remember operating system commands. If you want to copy an entire disk, simply drag one disk icon on top of another, instead of typing something like `COPY A:*. *B:`.

After a while, all the pointing and clicking actually gets to be a nuisance. The experienced user often wants a way to type in commands without having to use the mouse. A set of commands used with a disk operating system is called a *command processor*.

MichTron's **DOS Shell** is an MS-DOS look-alike command processor. Regardless of your feelings about IBM, MS-DOS, etc., DOS Shell is an excellent alternative to the GEM desktop. What makes it so useful is the power it makes available to you. Directory listings can easily be made of entire disks, individual subdirectories (folders), or all subdirectories on a disk.

One of the many useful features of the shell is *redirection*, which means sending the output of a command to someplace other than is usual. For example, you may want to create a file on your disk containing a listing of all the files on that disk. It's easy with DOS Shell. Simply issue the directory listing command and redirect the output (the list of files) to a file, rather than the screen.

Another useful feature of DOS Shell is

the ability to use *batch files*. A batch file lets you automatically run a group of programs or DOS commands, simply by typing the name of the desired batch file. This is useful for common, repeated operations—like setting up your computer at the beginning of a session.

Other useful commands include: COPY, RENAME, ERASE, TYPE and MORE (a filter for displaying the contents of a file, one screen at a time). DOS Shell also contains commands for creating, removing and changing directories.

DOS Shell retails for \$40 (from MichTron, 576 S. Telegraph, Pontiac, MI 48053 — (313) 334-5700), and comes with a reference guide and tutorial. Fortunately, the disk is not copy protected, so you can place the shell on every ST disk you own. I haven't mentioned *all* of the features of DOS Shell due to space limitations, but I do think the more you use it, the more uses you'll find for it.

Overall, DOS Shell can be recommended as an alternative to the GEM desktop, and as a way for experienced (or soon-to-be-experienced) ST users to get more out of their computers. Further, if you use an IBM PC or compatible at work and an ST at home, DOS Shell will be especially useful.

One of the limitations of the current ST operating system is that a maximum of six desk accessories are allowed on the desktop at a time. You don't have to be a power user to start running out of space pretty fast—adding a calculator program, com-

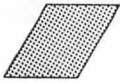

mand processor, the Atari control panel and other accessories. Fortunately, MichTron has come up with a combination desk accessory that does, well, just about everything. It's known as **Cornerman**, because that's where it resides on your computer's screen.

First, you should know that Cornerman is a GEM-based desk accessory; it's only available when you're running a GEM-based application program, the kind of program that has "Desk" as the first drop-down menu name in the top left-hand corner of the screen. If you're using a non-GEM program, it's impossible to use Cornerman. That may be its biggest failing. Luckily, as time marches on, more and more ST products are arriving as GEM-based programs.

Dropping down the desk menu and clicking on "Cornerman" brings up a screen with about nine choices. The most obvious (but not necessarily the most often used) portion of Cornerman is the calculator. It has sixteen digits, operates in decimal, octal, binary or hexadecimal, and it sports three summing memories. What's more, logical and scientific functions (OR, AND, NOT, square root, reciprocal) are provided. A simulated "printing tape" keeps track of the last four numbers in the main display. One of my main uses for the calculator is base conversions. I can go from decimal to hex and back faster than you can say "Atari ST!"

Another major portion of the utility is the "Notepad." This is handy for making notes to yourself while using another program. Just pop down the desk menu, click on "Cornerman" then "Notepad," and you can enter text for later use without disturbing the program you're currently using. After you jot down the note, pop out of Cornerman—and you're back to where you were.

The ASCII table is handy when you have to figure out what codes to send to the printer. In fact, I often use the ASCII table in conjunction with the calculator, to determine various codes I'll need. I don't speak hex, so these two features are quite useful.

The "Phone Book" stores important names and numbers, dials through your modem, and even stores elapsed time. A print function lets you selectively print data from Cornerman data files. There is also a DOS window that allows easy access to MichTron's DOS Shell (or other command processor) from the desktop.

A "Fifteen Squares" puzzle is provided, too. From a scrambled position, the

object is to rearrange the pieces so the numbers 1 through 15 appear in order, from left to right and top to bottom. The game is mouse controlled and a good diversion from more serious work.

---

*“Cornerman puts a wealth of functions at your fingertips and is well worth \$50.”*

---

Another useful feature of Cornerman: the clocks. The analog clock can be displayed in its own window. The digital clock appears at the top right corner of the screen. If nothing else, it reminds you to set the time and date for file date stamping. The "Setup" window allows you to change many of Cornerman's default values. In addition, separate configurations can be saved to files.

Cornerman puts a wealth of functions at your fingertips and is well worth \$50. Unfortunately, it's a *large* program, requiring just over 200,000 bytes of memory. Thus, Cornerman will be most at home on a 1-meg ST.

**Alt**, also from MichTron, is a memory-resident ST desktop accessory, which allows you to program up to thirty-six different key combinations with any string of up to sixty characters. Whenever one of these keys (A through Z, 0 through 9) is pressed, together with the ALT key, the string previously defined to that key is substituted, and appears just as if you'd entered it from the keyboard.

Alt's key substitutions are automatic and instantaneous. Separate Alt key sets can be defined from the desktop and stored as files for retrieval. Definition of key sets and storage and retrieval of files occur from the desktop, so all require the GEM desktop or a GEM application to be in use. However, once an Alt key set's been loaded, it may be used even with a non-GEM-based program. After an Alt key set has been loaded, you can bypass any Alt key combination. Temporarily suspending a key substitution helps when you want to pass an ALT-plus-keycode to a program unchanged.

When the Alt "Editor" is accessed from the GEM desk menu, the top half of the Editor screen shows one-fourth of the defined keys. The other key assignments can be viewed by scrolling the window. In addition to text, you can assign control

characters to your key strings. Alt key set files are loaded, saved and removed from this same screen. Further, one key set, called the "autoexec" set, can be specified to load whenever the GEM desktop is initialized.

Since Alt installs as a standard GEM desk accessory and intercepts the keyboard driver directly at its source, Alt's key substitutions will work with almost all GEM application programs. Programs which modify the BIOS keyboard handlers or don't support the GEM menu structure may not work correctly. If you're unsure of compatibility with an existing program, check with MichTron. In addition, MichTron warns that Alt may not function properly with very old versions of TOS on disk.

If you want to make using your ST more convenient, Alt is an excellent way to do so. It sells for \$30 and works with either a color or monochrome monitor. The program requires about 60K of memory when installed as a desktop accessory.

MichTron has been around for a couple of years, making software for the Sanyo computer. They're now easily the most prolific software publisher of ST programs. Their policy of not copy protecting utilities is laudable, and should be honored by not giving, lending or receiving their software. The utilities are reasonably priced, offer good value and show MichTron's commitment to the Atari ST.

I've become rather outspoken on copy protection in the last year or so. I find it a real nuisance to have to do a lot of disk swapping. I'm also extremely paranoid about using the original of a program for regular day-in, day-out work. If the disk permanently "goes South," I'm out of luck.

However, I have nothing against copy protecting games. If a game disk happens to join that great arcade in the sky, I can get along without it until I can get another copy from the manufacturer. But for application software or utilities, there's no excuse for copy protection. Copy protection on this kind of software severely limits usefulness. And any copy-protected software cannot be transferred to a double-sided or hard disk for more efficient storage.

**Copy II ST** from Central Point Software (9700 SW Capitol Hwy., Ste. 100, Portland, OR 97219) represents the first professional disk backup program for the ST. It comes with a short, well written instruction manual and a list of over sixty programs that can be successfully backed



up. It provides a fast sector copier and a bit copier utility, for making "exact clones" of disks. The procedure typically requires you to first sector-copy the disk, then bit-copy a specific track. One or two disk drives, either single- or double-sided, can be used.

The program is easy to use and completely mouse driven. Information about progress of the copy is displayed on-screen in a two-dimensional grid called the "Copy Status Box." As Copy II ST reads a track, the letter R appears in each cell of the Status Box. As it writes a track, the letter W appears. Then, for every track successfully copied, a dot is left behind in that position. If either a read or write error occurred during copying, an indication is given.

Many manufacturers of computer software protect their products to physically prevent people from making copies to sell or give away. Under the copyright law, you have a right to make copies of software you've purchased, in the event your original disk no longer functions. This is the only right to copy afforded to you under the law. Making copies of disks with this or any other program, for any other purpose, is strictly illegal and a Federal crime.

Copy II ST works as advertised and retails for \$40. The program itself is not copy protected.

**Thunder!** is three programs in one: a real-time, 50,000-word spelling checker, a word expander and corrector, and a writing analysis tool. The \$40 program is published by Batteries Included/Electronic Arts (1820 Gateway Drive, San Mateo, CA 94404).

Two versions of the spelling checker program are provided on the disk. One is a desktop accessory available at any time other accessories are on-line. This version of Thunder! works with any GEM-based program. The other version is a stand-alone program that can be used with any file. It's useful for checking files created by non-GEM programs, as well as for checking an entire file created by a GEM program. The program runs from the desktop, and the possible word error is highlighted in context.

Once Thunder! has been loaded as an accessory and the Autoproof feature is turned on, the program follows your keystrokes. Whenever it detects an end of a word, it checks its memory-based dictionary to see if the word exists. If the word does not exist, you're offered several suggestions or given the opportunity to add

the word to a supplemental dictionary. If you accept one of the suggested word spellings, the program will backspace over the word and automatically type the correct spelling.

The 50,000-word dictionary takes up 80K, and the program about 40K. However, whenever the ST is booted, you're asked if you want to load Thunder! When used as a desk accessory, Thunder! and its dictionary take up about 100K. Fortunately, if you should need that extra memory at any time, you can simply call up Thunder! (the accessory) and disable it. This frees up the memory and saves you the hassle of rebooting.

In addition to a spelling checker accessory, Thunder! provides a word expansion feature. You define ahead of time how specific strings of letters or characters should be expanded. For example, I'm using the expansion feature right now. I have defined TN as *Thunder!*—so whenever I type TN, *Thunder!* is entered. The expansion feature is not limited to just one or two words; an entire sentence or paragraph can be defined.

Another use of the expansion feature is for automatic word correction. For example: I type fairly fast, but often make mistakes. When I "machine gun" my text, I don't take time to worry about spelling. I almost always misspell *because* as *becuase*. With Thunder's expansion feature, I can tell the program ahead of time, whenever it sees the word *becuase* to correct it.

Thunder! also provides a range of statistics—character, syllable, word and sentence count, and two types of readability indices. Both the Fog and Flesch indexes are used. These widely used tests indicate how many years of schooling are required for the average reader to understand what you've written.

I've received another spelling checker program, called **Haba Spell**. Where still available (Haba is no more), Spell costs about \$30. It's a GEM-based offering with a 17,000-word dictionary to help you find mistakes. Once a file is selected from the drop-down menu, it is loaded into memory. You then view the words as they're compared to the dictionary, in real time.

If Haba Spell can't find a word in its dictionary, the cursor stops where the word occurs in the document, and a list of alternatives is shown. At this point, you can select one of the alternative spellings, ignore the word or type in a new one. If the word is unknown to the dictionary, it can be added.

---

*“ . . . of the several spelling checkers I've tried . . . Thunder! is still the best.”*

---

Besides using Haba Spell's main dictionary, you can specify other dictionaries or files to use. You can also check an entire document file or a page at a time. To catch any misspelled words that might have been added to a dictionary, you can print its contents.

How does Haba Spell work? Frankly, it takes a while for the file to load at first, then the file is checked rather slowly. Also, the window containing the spelling alternatives is drawn each time the cursor stops—time consuming and visually annoying. Further, the program is copy protected and requires a key disk approach.

All in all, Haba Spell is no match for BI's Thunder! In fact, of the several spelling checkers I've tried—Hippo Spell, Regent Spell, Haba Spell—Thunder! is still the best. My advice? Buy Thunder! and get on with your writing.

**Macro Manager** is another desktop accessory. Originally from Blue Moon Software, marketed by now-defunct Shanner International, it may still be found on some dealers' shelves. It sells for \$70 and requires approximately 66,000 bytes of memory when installed. It has some similarities to—as well as a few differences from—MichTron's Cornerman.

Unlike Cornerman (which, when invoked, presents a ten-choice menu), Macro Manager first displays a screen where you can set the time and date, and specify whether you have a Hayes or Hayes-compatible modem. Once you're finished with this screen, the Macro Manager displays its main screen, consisting of a calculator, time and date display, tape print indicator (for printing calculations), and feature selection buttons.

The MacroAnalyst calculator is a twenty-function calculator that can be configured in either Reverse Polish mode (RPN, like HP calculators) or Algebraic mode (like most other calculators). Changing modes simply requires pressing the SPACE BAR. Calculator buttons are pressed by either pointing and clicking the mouse button, or pressing the ST main keyboard or numeric keypad.

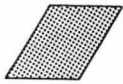

One of the calculator's useful features: built-in keys for calculating monthly loan payments. Unfortunately, standard notation (such as *PV*, *INT*, *PAY*—for present value, interest and payment) are not used, making it a little confusing to learn. Also, when a number is entered and you click on, say, *@pa* (*PAY* key), the number goes away—leaving you to wonder if you entered the correct figure. These criticisms aside, having loan computations available is a nice touch.

Another Macro Manager function is a Rolodex-type "Card File." Names, addresses and phone numbers may be kept as separate "cards" and printed. Later, you can search for particular names and, if you have an auto-dial modem, dial the phone number from within the window. The "Event Log" uses a similar card format, but keeps a separate database. Both the Card File and Event Log automatically time- and date-stamp your entries.

Macro Manager has an alarm function that automatically alerts you to appointments, phone calls, etc. Once you've entered the date, time and message of your alarm, it pops up in a separate window—as long as you're using GEM or a GEM-based program. Since the alarm record created by this feature is stored in a file, alarms can be set days or weeks in advance.

A notepad feature, similar to that offered by Cornerman, is provided by Macro Manager. In addition, a weekly planner lets you schedule appointments and reminders in a week-at-a-time format. The "Weekly Planner" and "Alarm/Clock Calendar" systems are integrated so that entries on the planner will signal an alarm. Display and alarm entries are both seen as planner entries. Moreover, if entries in the planner are input in a special format, you can later use the "Report" function to track the amount of time you spend on various projects: a list of projects and total time spent on each, for every day of the week.

Macro Manager also has a feature that lets you use your ST as a "smart" typewriter. Some formatting features are provided, such as margins, tab stops and justification. This might be useful in writing short notes or addressing envelopes.

Macro Manager consumes approximately 70,000 bytes of memory when installed as an accessory. The dual-mode calculator, built-in loan calculations and Rolodex differentiate it from Cornerman. Further, it requires only about one-third of the memory needed by Cornerman. On

the other hand, it costs more. At \$70, Macro Manager is a little pricey. Your decision to buy and use either Cornerman or Macro Manager will ultimately depend on your own needs.

**Action Pak** is four ST programs rolled into one (from Action Software, 69 Clementina St., San Francisco, CA 94105 — (415) 974-6638). It's a "Disk Labeler" that allows you to custom design your own 3½-inch labels; it's a "Banner Maker" that permits you to create one- to four-line banners up to seventy-two characters long; it's a typing program that turns your ST into a typewriter; and it's a SynFile database converter that lets you convert your 8-bit SynFile (Synapse) files for use with ST database programs. And all of this costs only \$40. Let me tell you more.

---

*“The Disk Labeler alone is worth the cost of Action Pak.”*

---

The label maker generates graphic (with an Epson or Epson-compatible printer) or regular print labels, as well as complete directory listings of your ST disks. GEM-based, it uses the mouse for all actions, except entering the name of the disk volume, and provides access to any desk accessories you may have loaded into the system. This and all the Action Pak programs work on either color or monochrome monitors, and single- or double-sided drives.

Label maker is very easy to use. Once the program is run, insert the disk you want to make a label of, and tell the program what drive to look at. Next, you choose the font—normal, italics or bold—in which you want filenames printed. Then you type in a disk name to be printed as a heading on the label and on the edge of the label. Finally, you can choose to sort the filenames to be printed, and select a border.

The border selection allows approximately thirty different patterns for graphic printing. Clicking on this option cycles through the various alternatives, letting you group your disks by border pattern. For example, all **DEGAS** disks could use a checkerboard border, all text disks a striped border, and so on... a handy feature.

Once you've dictated the label's look, you must choose which files to include, clicking the mouse button on every file

you want. When a filename is selected, it is highlighted. Clicking on a highlighted file deselects that filename. Here's the only flaw in the labeling program. There's no way you can select *all* files. You must select each and every filename, which can be tedious on a disk containing many files. What I'd like to do is select "all files," then deselect those I don't want, a simpler procedure (I think).

After aligning the printer, you're ready to print the label. About fifty labels are supplied with the program—more than enough to get started. Additional labels can be purchased from your local computer dealer. The result? Excellent. The Disk Labeler alone is worth the cost of Action Pak.

The Banner Maker program can generate banners with one to four lines of text on any printer. Options allow for the use of multiple fonts and even of single-height DEGAS fonts. However, be warned that some fonts won't look very good when printed in a banner. If you need a banner capability, it will be a trial-and-error procedure the first few times.

Before you create your banner, you have to choose how many lines it will be. Next, you select the font you want from the five or so that come with Action Pak, or from existing DEGAS fonts. You then choose to send the output to the printer or a disk file. Banners sent to a file can be printed later, or given to someone without the Banner Maker program, for them to print.

Banner position can be selected: left or right, justified or centered. Finally, you must choose the banner line before you enter any text. If your banner is four lines, each line has to be selected individually from the drop-down menu, rather than simply typing your entire message and having the program wrap the text around.

The "Typewrit" program is a desk accessory that lets you type in a line of text, backspace over it, correct it, etc.—and have the text print on-screen as you type. When you press the RETURN key, the entire line is printed and a linefeed is sent to your printer for the next one.

This program may be useful for addressing envelopes or other short writing tasks. By the way, if your printer can print in different fonts (such as bold, elite or compressed), you can send the special function codes to turn these fonts on and off within a typed line. When you're finished with the Typewrit accessory, just click on the upper left corner of its window and you'll be back to your desktop (or wherever you started).

The "Synfconv" program is, I believe, the first of many such programs to come, which will allow Atari 8-bit owners to use some of their existing files with the ST. While creating a way to run 8-bit programs on the ST is out of the question, due to incompatible microprocessors, converting 8-bit files for ST use makes a lot of sense. This is especially true for people who have a lot of 8-bit text, database and spreadsheet files that they want to use with an ST.

Before starting with Synfconv, you must transfer several files from your 800 to the ST. The easiest way to do this is to connect the serial port of an 8-bit interface (like the Atari 850) to the serial port of the ST. You'll need a null modem connector in between, so the two computers can talk to each other.

Each SynFile database has a minimum of three files associated with it, and a maximum of eighteen if you've spread the data over sixteen disks. All these files must be transferred individually, with a terminal program capable of file transfer protocol running on each computer.

Once the files are transferred, Synfconv is run on the ST. The program asks you for drive name and filename, and if you want the records displayed on the screen as they're converted. If you display the records, the program slows down considerably. Next, the program displays the makeup of the SynFile database, which may be useful for certain ST database programs since you'll be creating a file definition of this information.

At this point, Synfconv displays the number of records to be converted and, as it actually converts each record, displays the current record number. This gives you an indication of the program's progress. The following ST database programs can use the converted file: H&D Base (Mirage), dbOne (Versasoft Corp.), dbMan (Atari), HippoSimple (Hippopotamus Software), Regent Base (Regent Software) and Zoomracks (Quickview Systems). However, the command methods to bring in new files differ for each program.

An interesting and useful utility that will appeal to Neo-Chrome and DEGAS users is **Power Vision**. From Power Systems (13406 N.E. 84th St., Redmond, WA 98052 — (206) 885-7949), this \$25 program lets you create and display ST slideshow presentations. A plethora of video-style features (fades, wipes, blends, etc.) are used in a "command file" to control the effects and duration of your files.

With PowerVision, you compress the file you want to use by running an included program. Once the files are compressed, you create a command file.

PowerVision has blink, curtain, mesh, merge, rainbow, roll, show, and other commands. SPEED determines how fast the effect operates, and WAIT determines the length of time before the next effect. In addition, the ESCAPE key can be programmed on or off, to allow the user to interrupt the slideshow. Further, Neo-Chrome files that have been saved with a rotating palette can be displayed, and the speed of rotation altered.

Creating exciting and useful slideshows can take a good amount of work. For example, say you want to create a graph that shows three years' worth of sales, annotate each year, then draw a trend line to

indicate future growth. You would start by displaying a picture file showing the two axes and a title. Then you might MERGE the picture file containing the labels for the axes. Next, the first year data might be presented via a left CURTAIN. Next, the annotation for that year might be BLINKED onto the screen. So far, we have three separate picture files which would have to have been created ahead of time.

Although a certain amount of work is required to achieve dynamic results, several demonstration files are included on the PowerVision disk. Three complete demos are provided, and all include both the picture files and the command file needed to run the show. Not only is PowerVision useful, it's fun. What more could an ST computer user want? //

**SUBSCRIBE  
TODAY!**

**CALL TOLL FREE  
1-800-345-8112**

OR USE THE CONVENIENT CARD IN THE BACK OF THIS ISSUE.

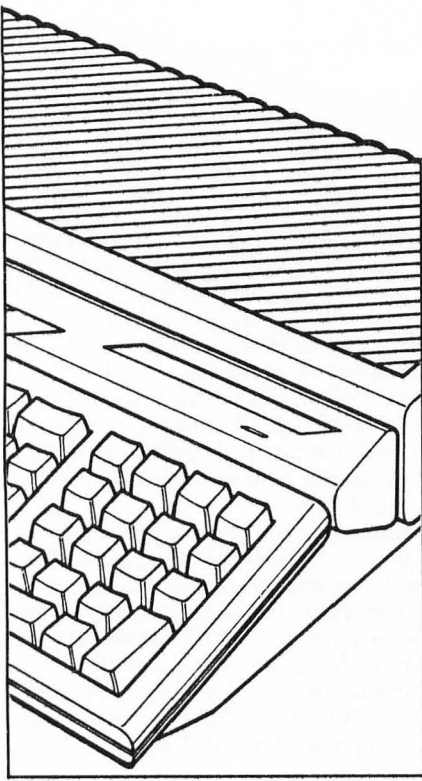

## THIS MONTH: ST software scene as seen at Summer CES.

---

Arthur Leyenberger is a human factors psychologist and free-lance writer living in New Jersey. He's been an Atari enthusiast for over five years. When not computing, he enjoys playing with robotic toys.

CompuServe — 71266,46  
Delphi — NJANALOG

---

---

by Arthur Leyenberger

---

One of the most impressive software titles I saw at this year's somewhat lack-luster CES was Eidersoft's **Tempus**. It's a GEM-based text editor aimed primarily at programmers. It's the fastest text editor or word processor I've seen on any micro-computer. It loads files off of a hard disk in what seems like microseconds. Further, it can scroll from one end of a 55K-byte document to the other in one-tenth the time it takes for 1st Word to do it. It's amazing to see it in action.

Tempus is more than just fast. It also has the features one would expect in a world-class text editor. It can operate in medium or high resolution; allows mouse or keyboard commands; can have up to four documents on the screen at once; provides automatic backup when saving; has loadable fonts, twenty programmable function keys, print spooler, and much more. One of the program's most outstanding features is its ability to automatically create a cross reference table of line and column references to multiple search strings. Once the table is created, clicking the mouse button will take you there instantly. Whew!

I must remind you that Tempus is a text editor, not a full-blown word processor. It's meant to be used by programmers when writing programs. It's compatible with the Megamax graphics shell, Beckemeyer C shell, GST shell and with most compilers and interpreters. If you're not a programmer, don't despair. A spokes-

person from Eidersoft indicated that a Tempus-based word processor is not that far off. If the word processor is as fast as the text editor I saw in Chicago, its speed will blow the socks off of every other word processor for the ST.

Eidersoft was also showing the **Pro Sound Designer**, a sound digitizer for the ST. Once captured by the 8-bit sound sampler, the music or sound can be edited and played back through the ST. Pro Sound Designer also gives you full control over the AY-3-8910 sound chip in the ST, to create sound effects and noises. There's also an optional hi-fi output to connect the output of the Pro Sound Designer to your hi-fi equipment for better sound.

**Pro Sprite Designer and Animator** is Eidersoft's product for people who are interested in computer animation. Sprites (moving objects) are created by the user on a pixel (picture element) grid, frame by frame. The frames may be swapped, moved, merged or copied—among other commands—and the user controls the color and position by using the mouse and an on-screen icon menu. The sprites created with Pro Sprite can be used with your own programs in BASIC, C and 68000 machine code. Full source code is provided with the sprite routines.

Another new Eidersoft product is **Flash-Bak & Flash-Cache** (one product). Flash-Bak is a GEM-based hard disk backup program offering a 1-megabyte-per-minute backup speed to a floppy disk. If you have two floppy disk drives, Flash-Bak may be configured to utilize them alternately

# ST user

for even faster overall operation. A 20-megabyte hard disk can be backed up in as little as 20 minutes. Files can be backed up by date, recent usage, wild card, or hard disk partition. In addition, files can be either compressed or encrypted (for security), or both during the backup process.

**Flash-Cache** is a RAM-based file cache utility to hold a part of the most recently accessed section of the hard disk in RAM. This has the effect of speeding up disk-intensive operations such as program compilation, database storage and retrieval, and normal saving/loading operations. Caches can be configured to any size to suit your system, and there's a fix for the infamous "Atari 40-file folder syndrome" (wherein more than 40 file accesses confuses the ST computer).

Other new Eidersoft software includes a terminal program and disk/memory editor. New Eidersoft hardware includes a ROM cartridge desktop accessory product, a drawing tablet and the smallest, cutest disk drives I've seen yet for the ST. All of these new Eidersoft products should be available by fall.

Another impressive software title was the **Film Director/Art Director** from Broderbund. Called the ST Director Series, these two products let you create graphic art, then animate it. The Art Director provides you with the tools and techniques to produce 16-color works of art. Such unique features as rescale, stretch, bend and bulge, along with the forty drawing "pencils," permit you to "push the envelope" on your creative expression.

The Film Director adds animation to your creations. Easy-to-use commands and built-in music and sound effects let you produce epics that make you look like a professional director. Both products are sold together for \$80, and will be available by the time you read this.

Still another dynamite program for the ST was **SCAD** (pronounced "S-CAD") by Xetec.

SCAD is a GEM-based, two-dimensional drafting/drawing program allowing mouse or keyboard commands that enable you to work on up to sixteen drawings at a time. The program permits accuracy to .001 of an inch and can zoom drawings up to 32 times. Drawings at any size can be saved in DEGAS format files, as well. SCAD features loadable font styles, an undo operation, rotation in .1 degree (yes, you read that correctly) increments, independent X- and Y-axes, a coordinate system that can be defined by moving the origin and choosing axis direction, grouping and about a dozen or so more features. Further, SCAD will sell for \$99, is not copy protected and will be available this month.

If that's not enough, SCAD is modular and expandable, so that, as new features (if they can think of any more) are added, drivers created or revisions made, they can be loaded and executed. Quite frankly, Easy Draw and Graphic Artist are going to get some tough competition when this product hits the street.

Unison World was showing their recently introduced **PrintMaster Plus**. This replaced their original PrintMaster, after

Broderbund Software won a legal battle claiming infringement on the now famous "look and feel" issue. The program allows the user to create custom signs, banners, stationery, calendars and greeting cards on a dot-matrix printer. To further enhance the user's enjoyment of their single ST product, Unison World also announced **Fonts and Borders**. Fonts and Borders provides twenty type fonts, ranging in size from 12- to 60-point type, and a selection of twenty borders. Font and Borders retails for \$35 and is out now.

Springboard was showing their **Certificate Maker** program for the ST. This \$50 program produces over 200 certificates to recognize, reward and encourage all kinds of achievements. The program also offers over three dozen stickers and gold seals to add flair to your certificates.

Firebird, makers of the excellent graphics text adventure game The Pawn, had two interesting titles at the show. **Universal Military Simulator (UMS)** is a program that allows you to set up your own battle scenarios in terms of locale, geographical features, armaments, troops, opposition and other variables, to provide the ultimate war game simulation. This \$50 program is sort of a "War Game Construction Set," to use the popular lingo. One of the interesting aspects of UMS is that any historical battle can be recreated exactly as it occurred—or with minor alterations to explore what-if possibilities. Universal Military Simulator should be on the shelves by the time you read this.

Another new Firebird product is called **The Advanced OCP Art Studio**. The Art



Studio is a graphics painting program that provides all kinds of input control—mouse, keyboard or KoalaPad. The program sports sixteen user-definable brushes, and three levels of magnification with pan, zoom and plot functions. Sections of the screen can be manipulated—by rotating, stretching, flipping, reducing, squashing, enlarging, or cutting and pasting. Support of major printers is also included in the package, which will sell for \$45 this fall.

What would a CES be without MichTron showing off even more new products for the ST? **ST-Replay** is a new program that allows you to digitize and replay various sounds, music or your own voice through the ST computer. The package comes with a cartridge that inserts directly into the ST cartridge port and accepts an audio input source. In addition to digitizing sound samples, ST-Replay also has an output jack that will connect to your hi-fi for even better sound. ST-Replay retails for \$160 and is available now, in color or monochrome.

**Digidrum** turns your ST into a digital drum machine. For \$40, you can create

any type of drum pattern, with up to sixteen voices, on your ST. Digidrum is compatible with ST-Replay, meaning it can use sampled sounds for creating the beat, as well as play back the digitized drum patterns through your hi-fi.

Another new MichTron item is **STuff**, a \$40 collection of twenty-one utilities for your computer. Utility programs for such functions as autobooting a selected GEM program from the desktop, encryption/decryption of files and file comparison are included. **Make It Move**, version 2.0, is an animation program that will bring life to your graphic paint files. All sorts of video-style fades, wipes and pans can be used to create an interesting and professional-looking animation display. Make It Move is selling now for \$70.

Timeworks was showing several new and useful products for the ST. An updated **WordWriter ST** gives you an integrated 60,000-word thesaurus, mail merge function, personal dictionary, line and column counter—and works better with a hard disk. All this, plus the features that have already made the original one of the most popular word processors for the ST, is available now, at \$80 retail.

**Partner ST** is a memory-resident desktop accessory program. It brings you twelve instantly available accessories, such as an on-line thesaurus, appointment calendar/date book, memopad, telephone list and auto dialer, expense account manager, time keeper, alarm clock, financial

calculator, typewriter and DOS command interpreter. Partner ST is currently selling for \$70.

**Timeworks Desktop Publisher** is a new program that will let you easily create reports, brochures, newsletters, forms and advertisements. In addition to a full-featured word processor, the desktop publisher contains a variety of font styles, kerning, italicizing, outlining, left, right and middle justification, automatic reformatting, and much more. Also provided are page design commands, drawing tools and the ability to import illustrations from leading graphic programs directly onto your page. The program is due to be released later in 1987, and no price has yet been announced.

Digital Vision was demonstrating two hardware products for the ST. **Computer-Eyes** is a \$250 full-color video digitizer. The product has been out since early 1987 and features video capture in any number of gray levels, support of all ST graphic modes (including the high-resolution monochrome), automatic calibration of brightness, contrast and color balance, and support of DEGAS, Neo-Chrome, etc., files. The new product is a black-and-white video digitizer for the ST at \$150. It too can capture images from any NTSC or PAL composite video source (VCR, videodisk or video camera), offers automatic calibration and supports standard ST graphic file formats.

Micro D was showing a 2/4-megabyte memory board for Atari ST. The board is said to install without soldering and will be available (sans chips) for \$160. Sixteen chips are required for the 2-meg upgrade, thirty-two for 4 megabytes. Chips can be ordered directly from Micro D or purchased elsewhere.

Hybrid Arts was demonstrating their \$2000 **ADAP Digital Sampling System** for the ST. Although it may seem expensive, the ADAP system offers you the sound quality of compact discs and provides the means to easily manipulate digitized sound samples in real time. This is clearly a professional product meant for professionals.

And that's that. While this CES brought no earth-shattering announcements, there was plenty for an **ST user** to examine. I've given you "just the facts, ma'am." //

**GRAPHIC CREATIONS**  
New For the Atari ST!

**CHRISTIAN ART  
COLLECTION**

The first in a series of graphic art products for the Atari ST containing 75 of the most frequently used Christian-oriented graphics. This disk library is compatible with the ST versions of Printmaster. We feel that this product will be a wonderful addition to your current graphic art library.

To obtain your copy of the Christian Art Collection, send a check or money order for \$24.95 + \$3.00 shipping to:

Graphic Creations  
3451 Plainfield Ave., N.E.  
Suite #157  
Grand Rapids, MI 49505

Visa & Mastercard orders  
Call (616) 698-1959

Michigan residents add 4% sales tax.  
Printmaster is a trademark of Unison World

CIRCLE #123 ON READER SERVICE CARD



24500 Glenwood Hwy. • Los Gatos, CA 95030  
**(408) 353-1836**

**NOW!**

YOUR ST BECOMES A PC  
WITH

**"pc-ditto"**

FROM  
AVANT-GARDE SYSTEMS

SUG. RET. \$ 89.95

Instant shipping (or as fast as we can). Mastercard & Visa accepted (no extra charge). Shipping fees based on weight: min. \$3.00. C.O.D., add \$1.90. California customers add 6.5% sales tax. Order by phone (Mon-Fri. 10 a.m.-5 p.m. PST). Order by modem (daily 6 p.m.-9 a.m., 24 hours weekends) from our online TeleCatalog. Prices subject to change without notice.

CIRCLE #124 ON READER SERVICE CARD

# Database Delphi

## ST matters discussed in the Atari Users' Group SIG on Delphi.

by Matthew J.W. Ratcliff

In developing my latest program for **ST-Log**, I wanted a way to change from medium to low resolution from my own software control, while avoiding the use of "set preferences" from the desktop. Below is a forum discussion on that subject.

From: DLM (Dan Moore)  
To: Kurto (Kurt Oestreich)

To change resolution, all you have to do is make an XBIOS call: Setscreen (logical address, physical address, resolution). Use a -1L (long) for the logical and physical screen address, which prevents the system from changing those settings. Use a 0 or 1 for low or medium resolution, respectively. You *don't* want to try setting the mono monitor to medium.

If you're willing to do a fair amount of work, you can do the windows, etc., yourself. But to get them to look the same requires a lot of drawing (little details like dither patterns).

From: MATRAT (Matthew J.W. Ratcliff)  
To: DLM

Regarding Setscreen (logical\_addr, physical\_addr, rez), if both \_\_addr values are -1, then will it just change the resolution of the screen RAM you're viewing *right now*? You grab resolution first, and restore that resolution with setscreen upon exiting to the desktop, correct? What happens if you change resolution and exit to the desktop without restoring it first? How will it affect a picture on the current display?

From: DLM  
To: MATRAT

I don't think you can change screen resolution without clearing screen RAM. The "side effects" of this function aren't very well documented, but I'm almost positive that resolution changes cause it to clear RAM. (Try it though; I may be remembering "features" of RAM TOS instead of ROM TOS. I don't use this call at all.)

GEM is really stupid about the screen resolutions; it checks once (during initialization time), then *never* reads it again. So, if you change resolutions then exit to the desktop, the system will be firmly convinced that you're in the original resolution, not the new one. And the screen display will be slightly strange. (Have you ever run the non-color Magic Sac in color? You get two screen images "beside" each other.)

The only "real" use for this function, once GEM is up, is to get double buffering of the screen. Several GEM games use it for that.

From: MATRAT  
To: DLM

Thanks, Dan. What I'd like to do is allow the user to select resolution *after* he's in the program, while he's *in* the program. If he's looking at a medium resolution picture and wants to view some in low resolution, then shift it down to low resolution. So long as I restore the proper resolution and palette before exiting, the desktop will be happy, correct?

What about dialog boxes? If I'm changing resolutions and the system doesn't know about it, what will happen to the dialog boxes? (Or is this nearly impossible, unless I figure out an illegal way to fake the system into believing it's in a different resolution—even though you haven't done a "Set Preferences" from the desktop?)

From: DLM  
To: MATRAT

You can change screen resolution anytime you like. Of course, all the AES and VDI routines still "believe" the screen is in the other resolution. (There's no way to change them without a complete reinitialization of GEM—not a very smart design.) So once you change resolutions, it's up to your code to do all screen I/O. (You can use Line-A calls with a little fiddling.) You can do this, but it's a huge amount of work to handle all the screen I/O, if you want things to still look like GEM.

"Set Preferences" doesn't change any system variables to tell GEM it's a different resolution. It just changes the resolution, then forces a warm boot (reloading all the .ACC, etc.).

Without finding illegal ways to reinitialize all resolution-dependent information (such as RSC file data) throughout the entire system, it's virtually impossible to perform many GEM AES and VDI functions following a software-controlled resolution change. The resolution changes are most frequently used in DEGAS picture-playing

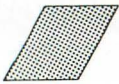

utilities, where only the picture is displayed and no other GEM services are required.

### More nightmares.

In a follow-up to my article "Nightmare Repair," I got the following message:

From: ANALOG2 (Charles Bachand)  
To: MATRAT

I see that the friendly neighborhood Radio Shack is now selling the General Instruments version of your favorite Yamaha sound chip for only \$9.95, plus tax.

So, if your ST's printer interface quits working, sound effects cease, or drive selects just don't select anymore, Radio Shack may be an affordable source for the repair chip to do the job.

### Delphi tricks and tips.

Quite often on Delphi, the subject of a particular topic thread needs changing. You may start out talking about video games and end up discussing politics. This makes it difficult to follow a "logical" thread of information.

When you're planning to reply to a mes-

sage with a different topic of interest, use the ADD command, instead of REPLY. This allows you to enter a new topic and automatically creates a new thread for others to follow. The biggest drawback is that you must remember the spelling of the person's name you had planned to reply to. Your capture buffer comes in handy here; just go into the edit buffer and review the last message you read.

Recently I've been editing messages, changing only the subject. This doesn't affect the thread at all, but gives users something meaningful to search for. If you reply to a message and later realize the subject is all wrong, you can easily change it. (You're only allowed to edit your own messages without SYSOP-level access.)

After reading the misnamed message, enter EDIT at the FORUM prompt. When the EDIT prompt comes up, enter SUBJ. At the SUBJ: prompt, enter a more appropriate subject name. Enter TOPIC at the EDIT prompt to change that, or TEXT to modify the content of your message.

Press RETURN at the EDIT prompt to return to the forum. //

*Matthew Ratcliff is an Electrical Engineer with the perfect job. He works at McDonnell Aircraft in St. Louis and gets paid to program software engineering in C and PL1, for a high-tech imaging system used to evaluate ultrasonic test data taken on fighter aircraft parts. When he isn't programming at McDonnell or hacking at home, he's teaching his two young sons to play video games and instructing them in the art of computer-speak.*

# Release the POWER of your mouse

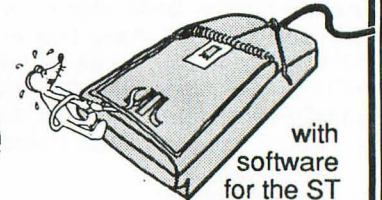

## TextPro

Write a novel...



**TextPro**—This is a serious word processor! Written with speed and maximum control in mind. Advanced features—mail merge for form letters..., multiple columns, automatic table of contents, automatic index, sorting (to alphabetize list of words) and define up to 30 user definable keys. Full screen editing with mouse or keyboard. **\$49.95**

## PaintPro

Create a masterpiece...



**PaintPro**—Draw upon your creative talents with **PaintPro**, the GEM-based, full-page graphics design package. Multiple windows. Cut & paste. 16 tools. Variable line width. Define your own fill and line patterns (up to 32 in memory at once). **\$49.95**  
**PaintPro Library #1**—Many clip-art pictures, 5 GDOS fonts. Degas compatible. **\$29.95**

## DataRetrieve

Manage a mailing list...



**DataRetrieve**—Data management was never this easy! Design your database using the mouse. *Lightning-fast* operation; tailorable display; user-definable reports; up to 64,000 records. Supports multiple files. Includes RAM-disks. Complete search, sort and file subsetting. Works with TextPro. Easy printer control. Five setups included. **\$49.95**

## PowerLedger

Plan a budget...



**PowerLedger**—Finally, a full-powered spreadsheet for your ST. Powerful, large capacity (65,000 by 65,000 cells) spreadsheet. Built-in calculator, online notepad and integrated graphics. Seven different chart types (pie, bar, 3D bar, line, etc.) Multiple windows (up to seven). 14 digit precision with 37 math functions. **New Version!** **\$79.95**

Ask about any of the 14 books in our ST Reference Series

Call now for the name of the dealer nearest you. Or order direct using your credit card. Add \$4.00 per order for shipping. Foreign orders add \$12.00 per item. Call or write for your free catalog covering our software and books. 30-day software guarantee. Dealers inquires welcome—over 2000 dealers nationwide.

# Abacus

P.O. Box 7219, Dept. N9, Grand Rapids, MI, 49510  
Phone 616/241-5510 Fax 616/241-5021 Telex 709-101

CIRCLE #125 ON READER SERVICE CARD



# RAMmer

## Here's that RAMdisk your ST's been crying for.

by Maloney

If you're new to the 16-bit world, you may be confused by the term *RAMdisk*. In short, a *RAMdisk* is a program that fools your computer into thinking that a section of memory is actually an additional disk drive; data transfer occurs at the speed of the MC68000 processor, not at the much slower rate of an electro-mechanical drive. Although it is possible to implement such a program on a 64K 8-bit machine, its usefulness is limited because it's impractical to dedicate more than about 8K of memory to the *RAMdisk*.

If you've used 1st Word, then you know the cycle—write, save to disk, print from disk, reload from disk, edit, etc. And, if you're a programmer, you also know the tedium of developing a program using an assembler or a compiler. You seem to spend all your time waiting for disk drive operations. That “busy bee” mouse cursor begins to look like a snail.

If, like most ST owners, you have only one single-sided drive, you already know the agony of the repeated disk swaps required when copying multiple files from disk to disk. Yet, insofar as commercial *RAMdisk* programs cost as much as some application software, even ST users who are familiar with the advantages of using a *RAMdisk* may put off buying one. After all, if you've just bought a modem, which do you need more—a terminal program or a *RAMdisk*? Sound familiar? Then relief is in sight!

### How it works.

If you're not interested in the “innards” of the program, please feel free to skip forward to the section on installation and use. For hackers, I offer the following details of the operation. The included source code is thoroughly documented, so I'll be brief.

The ST allows for up to three *physical* drives—two floppies and one hard disk. Yet there are provisions for up to

sixteen *logical* drives. If you have only one floppy, then you're familiar with this concept: when you want to do a disk copy, you drag the drive A icon to the one for drive B. Because TOS knows how many drives are actually connected, it treats the one *physical* drive as two different *logical* drives. Logical drives A and B are dedicated to floppies, and C is dedicated to a hard disk.

To implement a *RAMdisk*, three vectors used for hard drive access are changed to point to new routines. Each of these routines tests to see if the operating system is attempting to access the *RAMdisk*. If not, the default hard drive routine is invoked; if so, the *RAMdisk* routines come into play.

### Optimizing memory usage.

Experienced assembly language programmers may cringe when they first examine the source code, because I've put some of the code in the RAM buffer. The reason is that a *RAMdisk* has two sections: initialization and implementation. Of course this code will be overwritten, and yet, it doesn't matter—it's needed only when the program is first executed.

This technique saves 100-plus bytes over the same code written in a standard straight-line fashion. Even though the ST offers us a tremendous amount of RAM with which to work, that's no reason to adopt a cavalier attitude toward it. You never know when that extra memory might come in handy. To my knowledge, this program has the lowest memory overhead of any *RAMdisk* available.

### Installation and use.

The assembly language source code is provided only for those readers interested in the theory of operation. Use the BASIC loader to create your copy of the *RAMdisk*. It will prompt you for the drive identifier and the desired capacity in kilobytes. The name of the file it creates tells you the specifications of the *RAMdisk*. For instance, `RXD_D220`.

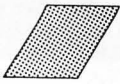

PRG means that the drive identifier is D and the capacity is 220K.

I suggest a drive identifier of D or higher. Click on the drive A icon, then select "Install Disk Drive" from the options menu. Enter the drive identifier and the disk name, and then click on "Install." (With TOS in ROM, the drive name can be RAM DISK. TOS on disk requires RAM\_\_DISK.) Finally, you move the new icon to a convenient location and save the desktop.

By the way, if you choose a drive identifier other than C, the RAMdisk icon will appear on the desktop on power-up, even if the program hasn't been invoked. To avoid confusion, you could to put the program into an AUTO folder.

It does take some practice to set the RAMdisk size to the correct value for your particular application. For example, if you're using it to copy multiple files with a single-drive 520ST system, the operation will slow down considerably if you use a size over about 220K. The reason is that it restricts the amount of memory TOS can grab for its own buffer. Desktop accessories also place limits on RAMdisk size, as do print spoolers.

### Special note for hard disk users.

One of my motivations for writing this program was that all of the RAMdisks available, either commercial or public domain, limited the drive numbers to the range of C-F. No one had adjusted to the hard drive user who partitioned his/her drive into four sections. **RAMmer** expands this range to include drives G-P. You can now have a RAMdisk and still use the full potential of your hard disk.

### A few final notes.

Experiment. Keep in mind that an application opened from a RAMdisk actually occupies memory twice—once as a RAMdisk file and again as a program loaded into memory. Word processors, spreadsheets and programming languages create additional files, and there must be enough free RAM and RAMdisk storage to accommodate them. You must also remember that anything stored on the RAMdisk will be lost when you push RESET or turn the machine off. Save files to a real disk first.

By the way, there are several RAMdisks floating around out there, claiming to survive a system reset. They don't really do so; they prevent a true reset. I don't recommend them, because if a program misbehaves so badly that you need to press RESET, then chances are good that RAM has been corrupted.

There is one hassle about using a RAMdisk, even if you put it into an AUTO folder so that it executes upon power-up: you must still manually transfer the desired files to it. "AutoTransfer," also in this issue, takes care of this chore automatically. //

*Maloney first became involved with computers in 1980 with a Sinclair ZX-80. He owned a Radio Shack Color Computer, a VIC-20, a Commodore-64 and purchased an Atari 520ST system in June, 1986. A typical hacker (in the original sense of that term) and an avid BBSer (that's with two Bs), his favorite computer language is assembly, and favorite projects are those handy utilities that everyone else is too busy to get around to.*

Listing 1.  
ST BASIC listing.

```

100 FULLW 2: CLEARW 2: LINE INPUT; "ENTER
DRIVE NUMBER FOR RAMDISK (C-P): "; DNS$
105 IF DNS$="b" AND DNS$<"q" THEN DNS$=CHR
R$(ASC(DNS$)-32)
110 IF DNS$<"C" OR DNS$>"P" OR LEN(DNS$)<
>1 THEN 100
120 LINE INPUT; "ENTER RAMDISK SIZE IN
KB (20-999): "; DS$: DS=VAL(DS$)+2
130 IF DS<22 OR DS>1001 OR STR$(VAL(DS
$))<>" "+DS$ THEN 120
140 OPEN "R" #1, "A:RXD_" + DNS$ + RIGHT$( "0
"+DS$, 3) + ".PRG", 2
150 FIELD #1, 2 AS D$: FOR I=1 TO 182: RE
AD AS
160 B$=CHR$(VAL("&H"+LEFT$(A$, 2)))+CHR
$(VAL("&H"+RIGHT$(A$, 2)))
170 LSET D$=B$: PUT #1, I: NEXT
180 B$=CHR$(0)+CHR$(ASC(DNS$)-65): LSET
D$=B$: PUT #1, 65: PUT #1, 77: PUT #1, 114
185 B$=CHR$(0)+CHR$(2^(ASC(DNS$)-65)): L
SET D$=B$: PUT #1, 148
190 HB=INT(DS/256): LB=DS-256*HB
195 B$=CHR$(HB)+CHR$(LB): LSET D$=B$: PU
T #1, 166: CLOSE #1: END
200 DATA 601A, 0000, 013C, 0000, 0000, 0000
, 0000, 0000
210 DATA 0000, 0000, 0000, 0000, 0000, 0000
, 4879, 0000
220 DATA 00D8, 3F3C, 0026, 4E4E, 5C8F, 4267
, 3F3C, 0002
230 DATA 2F3C, 0100, 0000, 4879, 0000, 00D8
, 3F3C, 0012
240 DATA 4E4E, DFFC, 0000, 000E, 7E00, 3E39
, 0000, 012E
250 DATA 0647, 0009, E347, 2C07, 13C7, 0000
, 00EB, E047
260 DATA 13C7, 0000, 00EC, 2E3C, 0000, 0009
, EFA6, 0686
270 DATA 0000, 01D8, 4267, 2F06, 3F3C, 0031
, 4E41, 0C6F
280 DATA 0003, 0004, 6608, 203C, 0000, 0120
, 4E75, 2079
290 DATA 0000, 0130, 4ED0, 0C6F, 0003, 000E
, 663A, 41F9
300 DATA 0000, 00D8, 7000, 302F, 000C, 223C
, 0000, 0009
310 DATA E3A0, D1C0, 226F, 0006, 082F, 0000
, 0005, 6602
320 DATA C149, 302F, 000A, 5340, 727F, 20D9
, 51C9, FFFC
330 DATA 51C8, FFF6, 7000, 4E75, 2079, 0000
, 0134, 4ED0
340 DATA 0C6F, 0003, 0004, 6604, 7000, 4E75
, 2079, 0000
350 DATA 0138, 4ED0, 23F8, 0472, 0000, 0130
, 21FC, 0000
360 DATA 0062, 0472, 23F8, 0476, 0000, 0134
, 21FC, 0000
370 DATA 007A, 0476, 23F8, 047E, 0000, 0138
, 21FC, 0000
380 DATA 00C4, 047E, 0078, 0008, 04C4, 4DFA
, 01C8, 3E3C
390 DATA 087F, 429E, 51CF, FFFC, 4E75, 0000
, 0200, 0002
400 DATA 0400, 0007, 0005, 0006, 0012, 0098
, 0000, 0000
410 DATA 0000, 0000, 0000, 0000, 0000, 0002
, 1A14, 0E08
420 DATA 2608, 103A, 140A, 060A, 060A, 0600

```



ST CHECKSUM DATA.

(see page 59)

100 data 751, 131, 477, 571, 776, 15  
 6, 796, 899, 412, 428, 5397  
 185 data 555, 654, 21, 815, 764, 211  
 , 65, 165, 102, 179, 3531  
 , 270 data 163, 956, 136, 946, 28, 208  
 , 162, 976, 23, 959, 4557  
 , 370 data 39, 168, 234, 801, 829, 28,  
 2099

Listing 2.  
 Assembly listing.

```

START          PEA          BUFFER          ;ADDR OF SUBROUTINE
               MOVE.W     #38, -(SP)        ;EXECUTE IN SUPERVISOR MODE
               TRAP      #14              ;XBIOS
               ADDQ.L    #6, SP           ;POP STACK

PROTOBT        CLR.W      -(SP)           ;NOT EXECUTABLE
               MOVE.W     #2, -(SP)        ;80-TRACK, SINGLE-SIDED
               MOVE.L     #501000000, -(SP) ;RANDOM SERIAL NUMBER
               PEA        BUFFER          ;ADDR OF TRACK 0, SECTOR 1
               MOVE.W     #18, -(SP)      ;PROTOTYPE BOOT SECTOR
               TRAP      #14              ;XBIOS
               ADDQ.L    #14, SP          ;POP STACK

               MOVEQ     #0, D7           ;CLEAR REGISTER
               RDU_NUMCL, D7              ;(USER K-BYTES) + 2
               ADD.W     #9, D7           ;DISK OVERHEAD
               ASL.W     #1, D7           ;CONVERT TO SECTORS
               MOVE.L     D7, D6          ;TEMP STORAGE
               MOVE.B     D7, BUFFER+19   ;HIGH BYTE IN 8086 FORMAT
               ASR.W     #8, D7           ;ISOLATE LOW BYTE
               MOVE.B     D7, BUFFER+20   ;MOVE IT

               MOVE.L     #9, D7           ;SHIFT FACTOR
               ASL.L     D7, D6           ;CONVERT TO BYTES
               ADDQ.L    #256+BUFFER-START, D6 ;BYTES TO PROTECT

KEEP           CLR.W      -(SP)           ;NO ERROR CODE
               MOVE.L     D6, -(SP)       ;BYTES TO PROTECT
               MOVE.W     #531, -(SP)    ;KEEP
               TRAP      #1              ;GEMDOS

HDV_BPB_TEST   CMPI.W     #3, 4(SP)        ;RAM DISK ACCESS?
               BNE.S     HDV_BPB_CONT    ;IF NOT TAKE BRANCH
               MOVE.L     #RDV_BPB_DATA, D0 ;ADDR OF RAM DISK BPB
               RTS        ;RETURN WITH ADDRESS

HDV_BPB_CONT   MOVEA.L    HDV_BPB_DFLT, A0 ;ADDR OF HARD DRIVE BPB
               JMP      (A0)             ;EXIT TO DEFAULT VECTOR

HDV_RW_TEST    CMPI.W     #3, 14(SP)       ;RAM DISK ACCESS?
               BNE.S     HDV_RW_CONT     ;IF NOT TAKE BRANCH

               LEA        BUFFER, A0      ;ADDR OF TRACK 0, SECTOR 1
               MOVEQ     #0, D0           ;CLEAR REGISTER
               MOVE.W     12(SP), D0      ;FIRST SECTOR FOR R/W
               MOVE.L     #9, D1          ;SHIFT COUNT
               ASL.L     D1, D0           ;CONVERT SECTORS TO BYTES
               ADDQ.L    D0, A0           ;ADDR OF FIRST SECTOR FOR R/W

               MOVEA.L    6(SP), A1       ;ADDR OF SYSTEM R/W BUFFER

               BTST.B     #0, 5(SP)       ;READ OR WRITE?
               BNE.S     RDV_RW_CONT     ;IF WRITE TAKE BRANCH
               EXG        A0, A1          ;REVERSE DIRECTION OF MOVE
    
```

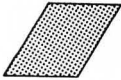

# RAMmer *continued*

```

RDU_RW_CONT    MOVE.W    10(SP),D0      ;NUMBER OF SECTORS TO R/W
                SUBQ.W    #1,D0          ;ADJUST FOR DBRA
OUT_LOOP       MOVEQ     #127,D1        ;(LONG WORDS/SECTOR) - 1
IN_LOOP        MOVE.L    (A1)+,(A0)+    ;MOVE LONG WORD
                DBRA     D1,IN_LOOP     ;IF NOT DONE TAKE BRANCH
                DBRA     D0,OUT_LOOP    ;IF NOT DONE TAKE BRANCH

                MOVEQ     #0,D0         ;NO ERROR CODE
                RTS      ;RETURN WITH PARAMETER

HDV_RW_CONT    MOVEA.L   HDV_RW_DFLT,A0 ;ADDR OF HARD DRIVE R/W
                JMP      (A0)          ;EXIT TO DEFAULT VECTOR

HDV_MEDIACH_TEST    CMPI.W    #3,4(SP)    ;RAM DISK ACCESS?
                    BNE.S    HDV_MEDIACH_CONT ;IF NOT TAKE BRANCH
                    MOVEQ     #0,D0      ;SAME DRIVE NUMBER
                    RTS      ;RETURN WITH PARAMETER

HDV_MEDIACH_CONT    MOVEA.L   HDV_MEDIACH_DFLT,A0 ;ADDR OF HDV_MEDIACH
                    JMP      (A0)          ;EXIT TO DEFAULT VECTOR

RDU_BPB_DATA    DATA
                DC.W    512              ;BYTES/SECTOR
                DC.W    2                ;SECTORS/CLUSTER
                DC.W    1024            ;BYTES/CLUSTER
                DC.W    7                ;SECTORS FOR DIRECTORY
                DC.W    5                ;SECTORS FOR FAT
                DC.W    6                ;SECTOR ADDR OF 2ND FAT
                DC.W    18              ;SECTOR ADDR OF START OF DATA
RDU_NUMCL       DC.W    152            ;(USER K-BYTES) + 2

HDV_BPB_DFLT    BSS
                DS.L    1                ;SYSTEM HDV_BPB VECTOR
HDV_RW_DFLT     DS.L    1                ;SYSTEM HDV_RW VECTOR
HDV_MEDIACH_DFLT DS.L    1                ;SYSTEM HDV_MEDIACH VECTOR

TEXT
;STORE SYSTEM HARD DRIVE VECTORS AND SUBSTITUTE RAM DISK VECTORS
BUFFER          MOVE.L    $472,HDV_BPB_DFLT
                MOVE.L    #HDV_BPB_TEST,$472
                MOVE.L    $476,HDV_RW_DFLT
                MOVE.L    #HDV_RW_TEST,$476
                MOVE.L    $47E,HDV_MEDIACH_DFLT
                MOVE.L    #HDV_MEDIACH_TEST,$47E

                OR.W     #8,$4C2+2      ;ACTIVATE RAM DISK

;CLEAR TRACK 0, SECTOR 2 THROUGH TRACK 1, SECTOR 9
                LEA     BUFFER+512,A6   ;ADDR OF TRACK 0, SECTOR 2
LOOP            MOVE.W    #2175,D7     ;(LONG WORDS/17 SECTORS) - 1
                CLR.L    (A6)+        ;INITIALIZE TO ZERO
                DBRA     D7,LOOP       ;IF NOT DONE TAKE BRANCH

                RTS      ;RETURN TO CONTINUE INIT
                END

```

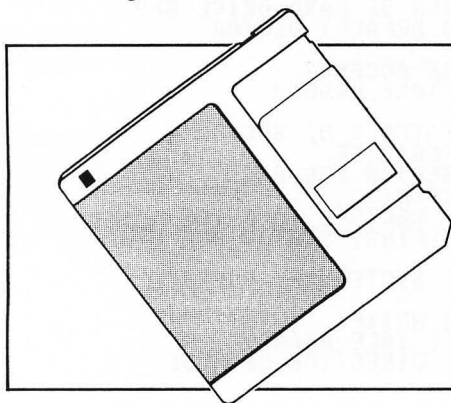

## Get this issue on Disk!

# \$9.50

PLUS \$1.50 SHIPPING AND HANDLING

## Call (617) 892-9230

## ComputerEyes

**DIGITAL VISION**  
**66 Eastern Avenue**  
**Dedham, MA 02026**  
**(617) 329-5400**  
**All resolutions \$249.95**

by Andy Eddy

In the October, 1985 issue of **ANALOG Computing**, Arthur Leyenberger reviewed the 8-bit version of **ComputerEyes**, the video digitizer by Digital Vision. Since that time, ST owners have hoped for something similar for their machines. Hippopotamus was first on the market with a digitizer, but its quality left a lot to be desired. (Now that Hippo is out of business, Navarone Industries has picked up the distribution of this digitizer, and may, in fact, rework the Hippo software to correct and clean up previous bugs.) MichTron is slated to bring out a German-made digitizer, as well (it may be out by the time you read this).

Because of Digital Vision's success with their original 8-bit version, many expected that **ComputerEyes** for the ST would give them quality digitizing hardware.

They won't be disappointed.

Sure enough, these folks have, again, handed users the tools to create super graphics—given the ST's resolution, that's to be expected. But they have exceeded their previous accomplishment by adding color capability to image acquisition, for low- and medium-resolution modes.

When I received the **ComputerEyes** package, I thought I was short a box or two, as there's so little required for digitizing. On the hardware side, there's a cartridge, measuring about 5x5 inches, that plugs into the slot of your ST. On the other

end of the cartridge is a standard RCA socket for accepting input from a video device (camera, video recorder or video disk player, for example).

When you boot up the software provided, the on-screen console varies with the resolution you're in. Both versions have sliders for brightness and contrast, as well as alterations that can take place from the various menu headings along the menu bar atop the screen. Low and medium resolution users have mouse-controlled buttons and sliders for all the different criteria, such as red, green and blue levels, scan speed and acquisition resolution. In high resolution, there's a choice of dither or high-resolution modes. We'll look at differences in picture types in a moment.

From there, it's so simple to get pictures that you'll wonder if you're doing everything right. In fact, all you have to do is line up the camera or freeze a frame on a prerecorded shot, and click on the "Capture" square on-screen. At that point, **ComputerEyes** will bring up a box that tells you how long you have to wait for the image to be received into memory and adjusted by the software. Once that process is finished, the image will be displayed on the screen.

If you choose, you can then go back to the control panel, change the components of the picture and have the software adjust it to your liking. This procedure doesn't change the original data that lies in memory, but is helpful in tuning up an

image before saving it to disk. Also, pictures can be saved in DEGAS (normal or compressed) or Neo formats, and loaded up into those editors later, for additional touching-up and enhancement.

Certainly, with three resolutions to pick from, there are some choices to make before digitizing a picture. You can alter the number of colors up to the maximum (to save some for later effects, for example), and also vary the separation of colors. The latter option will allow you to control whether different shades of the same color will be used, or if your palette will contain widely varied colors.

Additionally, with the color modes, you can take a picture in varying gray levels, instead of full color; **ComputerEyes** will take the image in sixteen low-resolution shades, or, as medium resolution, in four shades. Rather than just a simple black-and-white, you can give it a tint based on red, green or blue hues. Giving the image a red tone, for example, creates an old fashioned, "faded photo" look.

**ComputerEyes** makes it even more interesting by giving you choices *within* those choices. As mentioned before, this includes two different scan speeds in each resolution. In low and medium resolutions, you can pick between normal and slow acquisition rates. The slower speeds give **ComputerEyes** the opportunity to grab a better replica of the incoming picture, thus providing a less jagged image to work with. Timewise, normal acquisi-

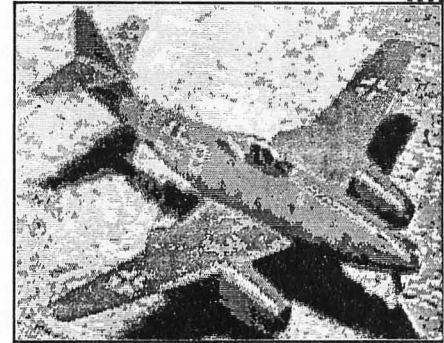

ComputerEyes at work.



tions take about six and twelve seconds for low and medium resolution, respectively; opting for the slower grab doubles that figure.

Let's go back to the high-resolution modes mentioned earlier: dither and high resolution. As explained in the manual, dither uses a pattern of dots to determine the gray level of the object. Because it smears the image a bit for its effect, this is the best mode to use for textured, multi-shaded items. On the other hand, the high resolution mode is strictly a two-gray-level shot, best used for highly defined pictures like line drawings or high contrast effects. Dithered images are taken in about six seconds; high resolution, in about twenty-four seconds.

Again, **ComputerEyes** is quite simple to use. The only exception to this is in the color mode, which tends to be finicky with regard to lighting and the number of colors in the item to be digitized. Trial

and error is paramount to getting the hang of this process, but, when you've worked with the product for a while, everything falls into place.

The only other problem I encountered was a vertical "striping" that occasionally permeated some low- and medium-resolution pictures. The only solution I could find was to reboot, but this gremlin was unpredictable as to when it would creep in. After mentioning this to John Pratt of Digital Vision, I was told this was a voltage problem their earliest releases suffered from, but that they've got it licked and will gladly replace any units showing those symptoms. Pratt also mentioned that they will be releasing a monochrome-only version of the product for \$149.95. It should be out by the time you read this.

**ComputerEyes** images are showing up in all applications: BBS and on-line network databases; desktop publishing; the

New *Aladdin* disk-based magazine; and even in stereo 3-D slideshows (for viewing with StereoTek glasses), turning an ST into an electronic View-Master. The public access channel on our cable system uses it in conjunction with **DEGAS Elite** to manipulate various pictures for integration into television shows. Using the Okidata 20-color printer gives decent hard copy of these graphics, as well.

To sum up, I guess I can't put it any better than Art did in his review a couple of years ago: "... it performs well and offers the Atari owner a unique and fun addition to computing capabilities." //

*The author would like to thank Ed Guinea, Laurel Cablevision and Cable 5 for their invaluable assistance in completing this review.*

## Aegis Animator

VERSION 2

by John A.S. Steel

and Elizabeth Vanture

AEGIS DEVELOPMENT

2210 Wilshire Blvd., Ste. 576

Santa Monica, CA 90403

Low resolution \$79.95

by D.F. Scott

Once a day, for about twenty-eight seconds, I find myself staring intensely at my television, viewing the masterworks of what may be the modern artistic renaissance: computer-generated animation. It may be Rockwell International's ray-traced sphere that decomposes into thousands of tetrahedrons; or CBS Sports' fantastic use of elementary shapes that merge together to form a gymnast in a pole vault, reconstituted in mid-flight to become an Olympic swimmer; or the Hoover "universe of vacuums" plotted within a myriad of self-evaporating euclidean shapes bouncing upon an infinite chessboard.

It's during those magical twenty-eight seconds that I yearn for Atari to complete its once-promised 68020 UNIX system, and port over whatever programs such commercial animation houses as Pacific Data Images are using—so I can show the world just what an Oklahoma artist, starved for motion on his canvas, can make move.

In the interim, we have **Aegis Animator**. In terms of functionality, it's a masterpiece, with methods of user interaction

which are outstandingly simple to comprehend—I sometimes wish there were an operating system this simple. Functions are selected either as English words through the GEM menu bar, or through a movable "toolbox" that contains self-explanatory icons representing the function, what type of element (points, lines or planes) the function is to be performed upon, and how it is to be performed.

What this program fails to offer is an *understanding* of perspective drawing, or the capability to determine just *how* we're viewing the animation scene. The objects within it may be mobile, but the angle from which we view it is stationary.

The program uses a constant perspective framework, wherein the principal vanishing point is at the center of the screen, the optic axis is perpendicular to the picture plane (you're looking directly at the center of the picture tube), and the two distance points are arranged along the horizon line so that each object appears small enough to fit inside the monitor. If those architectural terms are unfamiliar to you, **Aegis Animator** will make them no more familiar.

Instead, it acquaints you with the X-,

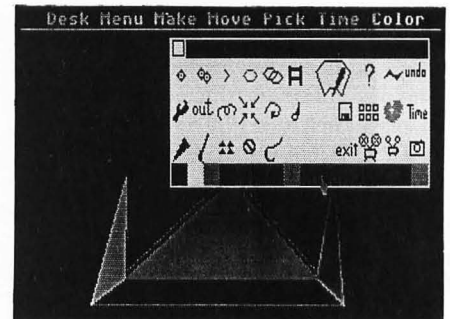

Aegis Animator.

Y- and Z-axes—perfect if you needed to calculate the square of a hypotenuse, but completely useless in perspective drawing. The program takes no account of viewpoint, nor the perspective of objects with relation to each other or the background. And there's no true background, only Neo-Chrome-generated "backdrops," as on a stage.

**Aegis Animator**, instead, concerns itself with the individual animated shapes, none of which may be generated to simulate whole *objects*. One starts with a polygon—a flat, multisided object with no more depth than a piece of paper. By mov-

ing the vertices of the edges of this polygon, one can create a seemingly three-dimensional shape, but of only one color. The shape, therefore, can't escape the trap of being a resident of Flatland. We're left with a form of computational origami, through which our animated shape may have wings, but cannot fly.

To animate a shape, one takes a flat polygon and, using the mouse, twists it, scoots it, rotates it, expands or contracts it to a new shape called a "tween." This is then "snapshot" by a click of the camera icon, and memorized. Precisely how the original shape was manipulated is also remembered, and logged in sequence as an entry in the "script." This script, when input to a word processor, is actually legible, using procedural terms like a high-level programming language. One could theoretically create external applications which could generate or alter **Animator** scripts.

Since this program contains a linguistic interpreter—however inaccessible by the user—similarities may be drawn between it and PostScript, the geometric language used in laser printer page layout. Each polygon is evidently interpret-

ed as a set of vertices and stored in memory sequentially as a one-dimensional array, with lines drawn between vertices, like connecting the dots in a coloring book. By trigonometrically obtaining coordinates for each vertex, and filling in between them with a single color, the folded-paper-like shape is obtained.

If **Aegis Animator** actually recognized three-dimensional objects with *depth*—say, something as complex as a cube—each vertex would have to be connected symbolically to three others, so the program's internal representation of a shape would be dramatically altered. As it is now, you can only make an animated rotating cube if you first create six flat squares, rotating and repositioning each square singly. The cube wouldn't have its own X-Y-Z axis; instead, each cube face would have its own axis.

With the animation script in linguistic form, one wonders why the program itself is incapable of displaying the text of it. Were **Aegis Animator** equipped with a text editor, the user could have been given true control over the script contents. With the current input method, any function applied to a shape at the middle of

the script will affect its appearance until the end; and any attempt to compensate, by applying the opposite function later in the script, will only result in a wobbly shape. As Master Po of "Kung Fu" might have put it: the script is like a river; any boulder dropped in the middle will forever alter its course.

**Aegis Animator** does offer optional cel animation, wherein clips from Neo-Chrome files may be loaded, "pasted" onto the screen, and moved about, although the mixture of cel and polygonal animations is a slippery one. As a cel animator alone, however, it's superior. If you enjoy two-dimensionality, or can simulate 3D well on your own, the excellent user interaction this program offers makes cel animation pleasant and enjoyable.

Yet to be created for the ST, however, is an animation program which provides even a few of the perspective design and modeling tools offered in 68020 UNIX CAD systems: **Aegis Animator** can be fun, if we don't pretend we're accomplishing anything worthy of artistic scrutiny and merit. The wait for serious animation for the ST continues. This is only Version 2, though. Let's hope for a Version 3. //

## Fleet Street Publisher

by Compac Consultants Ltd.  
MIRRORSOFT LTD.  
Distributed in the U.S.  
by SPECTRUM HOLOBYTE  
a division of Sphere, Inc.  
495 Third Street  
San Francisco, CA 94107  
(415) 882-7381  
All resolutions \$119.95

by D.F. Scott

My first professional computer writing experience was with a small regional tabloid called *The Computer Street Journal*. It was distributed monthly to nearly all the computer stores in Oklahoma and Texas. Its layout was something of a miracle: when I was there, that department consisted of a Macintosh, Aldus's PageMaker, and a pair of hands driven by a diabolical force that guaranteed enough typos to make English look like assembly.

Yet it was the layout "department-on-a-desk" that allowed CSJ to survive on a budget that made shoestrings look like transatlantic cables. That Mac kept one small publication alive, at a time when the

published word was growing scarce, and one city newspaper covered 10,000 square miles. All over the world now, the thunder of the presses is being replaced by the quiet whirr of the microcomputer, and the silence of the ST.

In Great Britain, *ST User International* (now *ST World*) magazine is laid out using **Fleet Street Publisher** and a laser printer—and it certainly doesn't look like a low-budget magazine, especially with its abundance of advertisers. In the U.S., **Fleet Street** is regarded as the contender to Publishing Partner; in the U.K., it's vice versa. The programs seem to speak with a different accent, and it's the British dialect we'll explore in detail here.

**Fleet Street Publisher** adheres to the

standards of GEM like no other program I've seen since GEM Draw. The reasons for this become more apparent once we realize that the twelve fonts provided (four or eight sizes each), are stored in the format of the IBM version of GEM. It seems this program was originally developed for the IBM PC, then ported over to the ST.

Note that versions 1 and 2 of the IBM GEM already have their own GDOS—which works well within the 640K restrictions of the 8-bit PCs and XTs. Entire 100-percent page layout reproductions on dual-size 640x800 monitors like the NGL Genius are feasible, with programs like Ventura Graphics. Current working copies of Atari's GDOS, by contrast, require over a megabyte of memory to store one page.

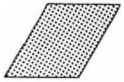

**Fleet Street** does not use Atari GDOS. As a result, a 520ST's memory can hold: the program (about 98K with resource file); any number of screen/printer fonts ranging in size from 1.6 to 12K; and page data, complete with enough overlapped clip-art to fill four 8½x11 pages—which generally consumes under 20K.

The program obviously uses some form of data compaction, which Atari's GDOS has—thus far—failed to use. **Fleet Street's** scheme—however it works—is apparently mathematical, so that each string of pixels in every character is “strung” or “unstrung” by multiplying its length with the magnification value. This value ranges from window-fitting (about 16 percent on the color screen) to an extreme closeup of 200 percent. The letters, as well as the rest of the page's contents, may thus be scaled to a convenient value.

Besides loading text from disk, **Fleet Street** allows text to be entered directly into the text or page window. Since some word processor text files (like those produced by 1st Word) have so many weird characters, they have to be converted before being imported. Although the text window does offer some editing features, its contents are displayed in a proportionally spaced graphic format, which makes manual conversion a slow and tedious process.

The first step in the text conversion procedure is to go into your word processor and resave the document as a single-spaced ASCII text file. Most of the weird characters will be stripped; unfortunately, this also replaces line feeds with carriage returns. These carriage returns wreak havoc with **Fleet Street**, which accepts them as signaling the end of a paragraph. We're left with several thousand half-line paragraphs.

The only easy way I've found to extract those returns is through a shareware utility by Ralph Walden, DCOPI, available from the Atari SIG on Delphi. It's smart enough to know that two carriage returns in succession signal the end of a paragraph for 1st Word, and will remove one return. A necessary feature for future **Fleet Street** releases: a provision for reformatting common word processor text formats.

Next on the agenda is the task of laying out the page. If you've ever seen the actual job of page pasteup performed in pre-microcomputer-age fashion, you will remember that a typesetting machine the size of a riding lawnmower is used to set the text into a long, column-wide strip of

REGULAR FEATURE

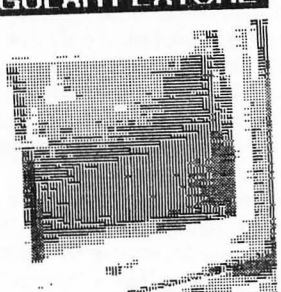

## STATUS REPORT

### FOLLOW THE BOUNCING BLITTER

D. F. Scott-

*It is the missing piece of hardware which could very well make the Atari ST the fastest microcomputer on the open market. It might also become the biggest embarrassment for Atari since the 1600SLE. For a year and a half, we've been promised the blitter chip, the hardware that makes it possible to transfer several successive bits of data as one raster, from one area of memory to another all at once. During that period of time, the projected release date has been continually pushed forward; as of the time of this writing, it is projected for 1 September.*

*Our primary source for this edition is Greg Pratt, Atari's Chief Financial Officer. Although he has had little or nothing to do with the design of the blitter component itself, two decisions made through him will affect not only the blitter's future, but the entire Atari production system. Because of press restrictions which prevented us from speaking, at the last minute, to Atari Service Division Chief Randy Bain, information from that department and from Research and Engineering was relayed to us by Marketing Communications Director Neil Harris.*

From the latest Atari corporate documentation, here is how the blitter enhancement will

work:

The main graphics routines in the ST are called the "Line-A" routines. These are used by all of TOS, including GEM, to produce lines or filled objects, control the mouse pointer and other graphic "sprite" objects, and to copy rasters from one region of memory to another--what is called a "software blit," since it is achieved by means of code and not hardware.

An assembly language program, for instance, places calls to these Line-A routines through a cleverly-designed trap--not a trap instruction per se, but a hardware-based diversion that passes control temporarily over to a subroutine. This trap is triggered by declaring in program memory, using the opcode DC.W, a word-length value (two bytes in length) between hex values \$A000 and \$A00E. It is from the high-order byte in these cases that "Line-A" gets its name.

It is the Line-A routine set, according to Atari documents, which will be carved in silicon, for an operating system speed increase approaching 50%, and a subsequent speed increase in all software which uses GEM or Line-A directly, especially those programs which rely upon Line-A for blitting.

There have been numerous complaints from developers who protest that the blitter is ineffective until accessed directly. Direct access of the blitter using

the new TOS, however, will be identical in nature to the relatively-slow internal software blit, through a word declaration of \$A00E and manipulation of the proper input/output registers--so the degree of protest may soon diminish.

The actual degree of performance enhancement can be measured, says Harris, by placing a call to the GEM Virtual Device Interface--namely #102, vq\_extnd. The system output register intout(6) should then contain the number of 16-word (32-byte) raster blits per second. Without the blitter, the system should register only 1000. Harris maintains that the reason developers have not seen --or forseem--much speed enhancement with the blitter is because they are using the old TOS.

The new six-ROM-chip TOS set will be sold with the blitter component, and perhaps also separately; however the form of the blitter package has not yet been decided. Some, but few, 1040s were equipped with a free slot for the blitter; but most existing STs are not "blitter-ready." The packages under consideration are: piEGY-backing the bare chip onto the 68000 CPU and then soldering in place, which can result in a sporadic overall system failure; offering the chip on a "daughterboard," although some STs may not have room for one; and, as Neil Harris reports, actually swapping

A sample page done with **Fleet Street**.

paper. This strip is cut to fit the layout, then pasted on a sheet that's ruled with guide marks in a shade of blue which isn't picked up by production cameras.

**Fleet Street** is designed in such a way that the user already familiar with professional typesetting will be able to draw similarities between elements of the program and ordinary typesetting. The text window thus becomes allegorical to the column strip, and the page window to the pasteup sheet. The program offers four pre-configured page sheet rulings, with the options of typing any modifications, or setting up the guides from scratch by typing in their coordinates. It accepts points/picas, metric, standard American inches, or "relative percentage units" as

units of measurement—the latter being relatively useless.

Using the guides assembled in the page window, the "microtypesetter" then decides where columns, headlines, borders and photos or clip art are to be placed. Column areas, for instance, are ruled by mouse-drawing a box for them in the same familiar GEM method as rounding up items in a desktop directory.

The box may then be scaled to fit the page guides, or to match the coordinates measured by the optional rulers which are along the upper and left window borders. These rulers—call them "side rules" if you wish—modify themselves to fit the current magnification, type of measurement and location of the window in



**NEW**

**ATARI 520ST SYSTEM  
FM PACKAGE**

- \* RGB Monitor or Monochrome Monitor
- \* Built in 3 1/2" SS Double Density Drive
- \* Basic
- \* TOS on ROM
- \* RF Modulator
- \* Full Manufacturer's Warranty

CALL FOR LOWEST PRICE



**ATARI 1040ST  
SYSTEM PACKAGE**

- \* RGB Monitor or Monochrome Monitor
- \* Built in 3 1/2" DS Double Density Drive
- \* Basic
- \* TOS on ROM
- \* Full Manufacturer's Warranty

CALL FOR LOWEST PRICE

**ATARI SF 314 DISK DRIVE  
DOUBLE SIDED/1 MEGABYTE STORAGE  
CALL**

**OKIMATE 20 COLOR PRINTER  
&  
ST PLUG N' PRINT  
\$205**

**SUPRA 20 MEG  
HARD DRIVE  
ONLY  
\$539**

**PC DITTO  
\$84.95**

**ST MODEM PACKAGE**

- \* AVATEX 1200HC MODEM
- \* ST MODEM CABLE
- \* ST TALK TELECOMMUNICATIONS PACKAGES

**\$145**

<p><b>PANASONIC</b></p> <p>PANASONIC 1080 159 PANASONIC 1091 189 PANASONIC 1092 299 PANASONIC 3131 269 PANASONIC 3151 409 PANASONIC 1592 419 PANASONIC 1595 449</p>	<p><b>EPSON</b></p> <p>LX 85 189 FX 86E 339 EX 800 409 EX 1000 549 FX 286E 479 LQ 800 469 LQ 1000 669 LQ 2500 929</p>	<p><b>STAR MICRONICS</b></p> <p>NX-10 169 NL-10 CALL NP-10 149 NX-15 329 ND-10 349 NR-15 479 NB-24/10 439 NB-24/15 (24 wire) 639</p>	<p><b>OKIDATA</b></p> <p>OKIDATA 182 249 OKIDATA 192+ 369 OKIDATA 193+ 559 OKIDATA 292E 449 OKIDATA 293E 599</p>	<p><b>CANON</b></p> <p>CANON A-50 279 CANON A-55 389 CANON A-60 349</p> <p><b>SEIKOSHA</b></p> <p>SP-180 169 SP-1000A 199 SP-1200 209</p>	<p><b>BROTHER</b></p> <p>BROTHER 1009 139 BROTHER 1509 379 BROTHER 1709 489 BROTHER HR 35 749 BROTHER 2024 LD 819 WINWRITER 5 839</p>
---	---	--	--	---	---

<p><b>MICHTRON</b></p> <p>BBS 2.0 48.95 Business Tool 31.95 Calendar 18.95 Comerman 31.95 DOS Shell 24.95 Echo 24.95 M-Disk + 24.95 Major Motion 24.95 Make It Move 44.95 Mi-Term 31.95 Michton Utilities 37.95 Cards 24.95 The Animator 24.95 Time Bandits 24.95 Mighty Mail 31.95 Personal Money Mgr 31.95 Pinball Factory 24.95 Financial Future 24.95 Eight Ball 18.95 Hard Disk Backup 24.95 Match-point 24.95 Karate Kid II 24.95 GFA Basic 48.95 Trimbase 62.95 Shuttle 2 24.95 M-Cache 24.95 GFA Draft 62.95 GFA Vector 31.95 Goldrunner 24.95 GFA Compiler 48.95 Realizer 149.95</p> <p><b>ST ACCESSORIES</b></p> <p>Flip'n' File II-Micro 19.95 Dustcovers...Call 3.5 Drive Clean Kit 16.95 Mouse Pad 8.95 Mouse House 6.95 6 Way Surge Protector 19.95 Anti-Glare Screen 19.95 6 FT SF 354/314 Cable 19.95</p> <p><b>ST DATABASES</b></p> <p>DB Man 96.95 Regent Base 57.95 Data Manager ST 48.95 Zoomracks II 77.95 Superbase Gem 94.95</p>	<p><b>ST ADVENTURES</b></p> <p>Hacker 17.95 Hacker II 25.95 Sundog 24.95 Black Cauldron 25.95 Ashal Trilogy 14.95 Universe II 44.95 The Pawn 29.95 Starglider 29.95 Dungeonmaster 24.95 Alternate Reality 26.95 Tass Times 25.95 Mercenary 26.95 Autoduel 32.95 Ogre 25.95 Defender of Crown 32.95 S.D.I. 32.95 Balance of Power 32.95 Ultima III or IV 38.95 Portal 32.95 Kings Quest 1, 2 or 3 32.95 Space Quest 32.95 Tracker 29.95 Colonial Conquest 25.95 Roadwar 2000 25.95 Wizard's Crown 25.95 Rings of Zilfin 25.95 Sinbad 32.95 Golden Path 29.95 Phantasia 1, 2 or 3 25.95 Leisure Suit Larry 32.95 Guild of Thieves 29.95 221 Baker Street 26.95 Empire 36.95 Bard's Tale 32.95</p> <p><b>ABACUS</b></p> <p>Textpro 32.95 Datrievie 32.95 Forth MT 32.95 Paintpro 32.95 Assempro 39.95 Powerplan 49.95 Abacus Books...Call</p> <p><b>ST TELECOMM</b></p> <p>ST Talk Ver 2.0...CALL BB/ST 31.95 Flash 27.95 I.S Talk 33.95</p>	<p><b>ST EDUCATIONAL</b></p> <p>Aesop Fables 31.95 Decimal Dungeon 24.95 Fraction Action 24.95 Kinderama 24.95 Read &amp; Rhyme 24.95 Math Wizard 24.95 Animal Kingdom 24.95 Speller Bee 33.95 Kid Talk 33.95 Math Talk 33.95 First Shapes 33.95 Read-A-Rama 31.95 Math Talk Fractions 33.95 Winnie the Pooh 16.95 Buzzword 27.95 1st Letters and Words 33.95</p> <p><b>ADVANCED ORDERS</b></p> <p>Magical Myths 31.95 All About America 36.95 Adv. of Sinbad 31.95 Arabian Nights 31.95</p> <p><b>ST UTILITIES</b></p> <p>Music Studio 32.95 Digi-Drum 24.95 Time Link 33.95 Midplay 32.95 Micro Cookbook 32.95 CZ Draft 64.95 EZ Track 39.95 ST Replay 99.95 Write 90 18.95 Fast 31.95 Labelmaster Elite 27.95 St Doctor 24.95 Back Pak 64.95 Video Wizard 39.95 K-Switch 25.95 Partner ST 44.95 Desk Cart 72.95 Music Construction Set 32.95 Smooth Talker 33.95</p> <p><b>ST WORD PROCESSORS</b></p> <p>Regent Word II 48.95 Wordwriter ST 48.95 Thunder 26.95 Microsoft Write...Call Word Perfect...Call</p>	<p><b>ST LANGUAGES</b></p> <p>Personal Pascal 49.95 Alice Pascal 49.95 Mark Williams C 114.95 Metaconco Pascal 69.95 Macroassembler 49.95 Lattice C 99.95 Cambridge Lsp 139.95 Modula II 67.95 Metaconco Make 49.95 Micro C shell 34.95 Modula II Developer...Call Fast Basic 48.95 True Basic 49.95 Fortran 77 124.95 LDW Basic 44.95 MTC Shell 84.95</p> <p><b>ST BUSINESS</b></p> <p>VIP Professional...Call Swiftcalc ST 48.95 Isgur Portfolio 124.95 Financial Cookbook 14.95 DAC Payroll 32.95 DAC Easy Accounting 44.95 Dollars and Sense 64.95 Sylvia Porter 48.95 A-calc Prime 39.95 Logitex Jr 57.95 Logitex Sr 89.95</p> <p><b>DESKTOP PUBLISHING</b></p> <p>Drawrite 99.95 Publishing Partner 99.95 Partner Fonts 19.95 Fleet ST Desktop Pub 74.95</p> <p><b>ST PRINT UTILITIES</b></p> <p>Rubber Stamp 18.95 Printmaster Plus 24.95 Megaloft ST 24.95 Art Gallery 1 or 2 18.95 Typesetter Elite 31.95 PM Interface 18.95 Certificate Maker 31.95 Library 1/Certificate Mkr 21.95 Print Shop...Call Fonts &amp; Borders/P.M. 21.95</p>	<p><b>ST ARCADE GAMES</b></p> <p>Winter Games 24.95 Rogue 24.95 Super Huey 25.95 Mean 18 27.95 Famous Course Disk 14.95 Leader Board 25.95 Brattacus 32.95 Silent Service 25.95 Flight Simulator II 33.95 Champ Wrestling 24.95 World Games 24.95 Video Vegas 24.95 Strip Poker 25.95 Little Computer People 16.95 Gato 24.95 Joust 20.95 Star Raiders 20.95 Chessmaster 2000 29.95 Tenth Frame 25.95 Shanghai 25.95 3-D Helicopter 32.95 Micro League Baseball 39.95 Gen Mgr/for MLB 19.95 '86 Team K For MLBB 16.95 WWF Micro Wrestling 39.95 Skyfox 14.95 Super Cycle 14.95 ST Pool 22.95</p> <p><b>DISKETTES</b></p> <p>Sony 3.5 SS/DD (10 PK) 13.95 Sony 3.5 DS/DD (10 PK) 18.95 Note: Buy Diskettes at these low prices when added to any other order.</p> <p><b>ST GRAPHICS</b></p> <p>Degas Elite 52.95 Easy Draw 64.95 CAD 3-D 32.95 Graphic Artist 124.95 Paintworks 25.95 1st Cadd 31.95 Aegis Animator 48.95 Pro Sprite Designer 36.95 Neochrome 34.95 Stereo Cad 3-D 67.95 Fonts for CAD 3D 17.95 ST Sprite Factory 25.95</p> <p><b>INFOCOM ST</b></p> <p>Bureaucracy 25.95 Enchanter 19.95 Hitchhiker 19.95 Leather Goddess 25.95 Lurking Horror 25.95 Moonmist 25.95 Stationfall 25.95 Trinity 25.95 Wishbringer 11.95 Zork I or II 25.95 Zork II or III 28.95 Hollywood Hijinx 25.95 All Invisiclues...CALL</p> <p><b>CASIO KEYBOARDS</b></p> <p>CZ 101...Call CZ 230S...Call</p>
---	---	---	--	---

No surcharge for Master Card No surcharge for Visa

To Order Call Toll Free **800-558 0003** P.O. BOX 17882, MILWAUKEE, WI 53217 ORDER LINES OPEN Mon.-Fri. 9AM-9PM CST Sat. 11AM-5PM CST

**ComputAbility**  
Consumer Electronics

TELEX NUMBER 9102406440 (ANSERBACK = COMPUT MLW UO)

For Technical Info, Order Inquiries, or for Wisc. Orders **414-357-8181**

ORDERING INFORMATION: Please specify system. For fast delivery send cashier's check or money order. Personal and company checks allow 14 business days to clear. School P.O.'s welcome. C.O.D. charges are \$3.00. In Continental U.S.A. include \$3.00 for software orders 5% shipping for hardware, minimum \$5.00. MasterCard and Visa orders please include card #, expiration date and signature. WI residents please include 5% sales tax. HI, AK, FPO, Puerto Rico and Canadian orders, please add 6% shipping, minimum \$6.00. All other foreign orders add 15% shipping, minimum \$15.00. All orders shipped outside the Continental U.S.A. are shipped first class insured U.S. mail. If foreign shipping charges exceed the minimum amount, you will be charged the additional amount to get your package to you, quickly and safely. All goods are new and include factory warranty. We do not guarantee compatibility. Due to our low prices all sales are final. All defective returns must have a return authorization number. Please call (414) 357-8181 to obtain an R.A. # for your return will not be accepted. Prices and availability subject to change without notice.



relation to the portion of the page being viewed.

The way GEM works, with only one window active at any time and the rest "dormant," isn't easy for the programmer to find a conventional data-transfer method between two windows. This is why DRI's GEM programmers conceived the GEM "clipboard," a RAM cache used to store data in transit between windows or between programs. The clipboard was another feature not ported into the ST version of GEM—and another feature masterfully duplicated by **Fleet Street**.

Once positions of text columns on the page window have been ruled in, text from the strip is sectioned out by dragging a rectangle around the piece to be cut, "picking it up" with the mouse pointer and placing it on the clipboard icon. It doesn't hurt to overestimate the amount of text to flow into the column; **Fleet Street** automatically handles overflow. In fact, it puts the overflow in a separate buffer with its own access icon.

The page window is then reactivated, and text is dragged from the clipboard into the first column, with any extra automatically activating the overflow buffer. More text may be transferred from the buffer to succeeding columns, where text may also be edited or repositioned.

In the sample, I selected the 10-point "Serif" font for the copy, which appears in my printout as it does in the page window at 100-percent magnification. The italicized first column is just as illegible on-screen as it is in print. It is in the vital category of dot-matrix output quality that Publishing Partner excels over **Fleet Street**. The latter's dot-matrix output, though much faster than the former's, can only be considered as proof quality.

Unfortunately, proof quality is all the current U.S. edition of **Fleet Street** offers, since its only printer driver is for the Epson FX80. Apparently, a laser printer driver of some sort must exist somewhere in Europe; but until it's released in the U.S., the program is no more applicable than the PC's Newsroom.

The first column on my page is left justified, without automatic hyphenation. I personally prefer this look because I deplore hyphens and I like the flush-left, ragged-right effect. It's attractive, and it leaves even spacing between letters and words, instead of the sometimes-compact/sometimes-dispersed spacing of the "full out" left-and-right-edge justification.

The right column is an example of **Fleet Street**'s automatic hyphenation, with full-

line justification. This splitting of words into two parts leads to mutations like "developers" and "relative-ly," making my text sound like a Confederate Army drill sergeant if read aloud.

Artwork to be placed in the upper right corner may be cropped from a clip-art file, which has items collected together by subject, like image \*.IMG files. Clip art is a necessity for publishers who don't have real art. A special conversion utility on the clip art disk allows Neo-Chrome, Art Director and DEGAS pictures of all resolutions to be converted to black-and-white \*.IMG files—**Fleet Street** does make real art available.

No matter what the manual says, however, when using the color monitor resource file, imported \*.IMG images may not be scaled or resized—though they can be cropped. An imported Neo picture would fall off the right boundaries of the page. So if you were thinking of importing a picture of yourself and all you have is a color monitor, you'd best be satisfied with just a nose or an ear.

While we're on the subject of color monitors, you may find it more convenient not to use medium resolution. Since the program was meant to run under 640x400's square pixels, 640x200 results in all screen contents being twice as long vertically as they will be when printed. Low resolution in this program is certainly bearable; at one time in the history of Atari, 320x200 was high resolution, and we were in awe of it then.

I did find one bug when trying to underscore my headline: I couldn't get the underscoring to stay on the screen longer than half a second before disappearing. It would return briefly once in a while, to peek in on matters, but disappear just as mysteriously. On a related matter, you'll notice the text you're reading has a tendency to **change styles often**. Those delimiters which denote when the styles change are stripped on importing a text file. If you want to leave style changes in, you have to delete the characters in the standard font, load the bold or the italic font, and retype them each time.

One minor complaint: **Fleet Street** expects the fonts to be on the same disk from which the text or page is loaded; it looks for those fonts immediately afterward. When it doesn't find one, the dialog box says *Error -33 opening file!* After a long struggle, wondering why it would not reload my page, I realized it simply couldn't find the fonts. So if you have a single-drive system and get that message,

just insert the Fonts Disk and poke the RE-TRY button.

Since **Fleet Street** and Publishing Partner are similar in price, the final judgment criteria for the two will be: print quality, ease of use and versatility. We've already established that Publishing Partner currently has the edge in print quality—at least on this continent. If the laser printout quality of the European magazine mentioned earlier is any indication, however, **Fleet Street** may soon take the lead in that category.

In ease of use, **Fleet Street**'s adherence to the letter of GEM's principles, along with its use of traditional typesetting methods, allow the amateur to comprehend 50 percent of the program from the very start. Publishing Partner, from my experience, isn't so readily comprehensible.

What the **Fleet Street** user doesn't pick up in the first hour can be learned in the first day, with one of the best program manuals I've ever read. It's written in plain English. The help files provided on disk are graphic text strips; and the clarity of the manual renders them entirely unnecessary.

Finally, there's the issue of versatility. **Fleet Street** is restricted to one dot-matrix printer driver with two modes of print, and twelve fonts, in sizes from 10 to 30 points. The fonts are external to the program, allowing them to be dynamically loaded into RAM and unloaded as necessary; yet **Fleet Street** recognizes only those twelve—no more.

The printer driver is built into the program and cannot be replaced or modified. New screen fonts, printer fonts, printer drivers, clip art and real art is released for Publishing Partner, it seems, every week—indeed, author Deron Kazmaier's font editor is public domain.

So, at least this week, Publishing Partner wins over **Fleet Street**. This may not be so by press time, as more competition enters the arena. Ready-Set-Go, silver medalist on the Macintosh, should be at the "Go" stage early next year; pressure is building for Aldus to port over PageMaker. Meanwhile, Font Factory continues to produce accessories for Publishing Partner, while revisions to **Fleet Street** may be in the works. At this time, the developments at Atari and DRI may totally alter the marketing environment for these two programs. Those who stand to benefit are small publishers on hairline budgets, and all their new writers, who'll be practicing for the big leagues. //

## Easy Draw

MIGRAPH, INC.  
720 South 333rd St., Suite 201  
Federal Way, WA 98003  
(206) 838-4677  
High or medium resolution  
Easy-Draw 2.06 — \$99.95  
Font Pack #1 — \$39.95  
Personal Draw Art #1 — \$29.95  
Technical Draw Art #1 — \$29.95  
NEC 24-Pin Printer Driver — \$19.95

by Matthew J.W. Ratcliff

**Easy Draw**, a sophisticated GEM-based drawing program, was strongly supported and enhanced over the past year, while its price was halved. In it, everything you create is an "object," and every object can be sized (dimensions changed while retaining proportionality), stretched (height or width adjusted independently), rotated, mirrored or duplicated. Its text handling capabilities are quite good, but certainly not as powerful as other desktop publishing packages.

It's important to remember that **Easy Draw** does not pretend to be a desktop publishing program; it can, however, fill that bill nicely in small applications, like newsletters or illustrated term papers.

**Easy Draw** is the most bug-free program I've had the pleasure to test run on the ST in a long time. The few complaints I have about this program are due to quirks in the user interface—minor annoyances that are easy to overcome. I've yet to find an outright bug, which is impressive considering all the complaints I've heard about the GDOS that **Easy Draw** heavily depends upon.

After using this program for a short while, I've found it simpler to create pictures with the *object* method, as opposed to the pixelated approach of graphic art programs such as DEGAS Elite or Neo-Chrome. To create the double-edged tomahawk in Figure 1, for example, I started by drawing one-fourth of an ellipse (an elliptical arc). To do this, simply click the right mouse button, and a "toolbox" pops up on the display underneath your mouse pointer. From the toolbox all drawing functions can be selected: a box or box with rounded corners, circle and ellipse, pie or elliptical pie, arc or elliptical arc (no lines connecting endpoints to center), line, sketch, polyline, or text entry.

Pointing and clicking the left mouse button on the elliptical arc icon sends control back to the drawing window, in the create mode. At this point, drag the

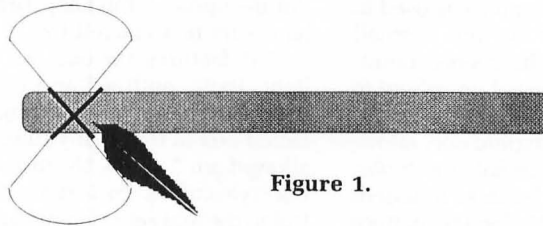

Figure 1.

object onto the display, while holding down the left mouse button. When the button is released, the object moves freely with the mouse, while the right mouse button will set the object.

Once the object is placed, it has a sizing box around it, which is a rectangle with small squares located at points where you can click and drag to stretch or resize it. You must always be aware of the current *mode* you're in, however. To return to the edit mode, you may click the right mouse button to bring up the toolbox, then click the right mouse button again to revert to the editing mode. The modes are indicated by a cross hair (create) and pointing hand (edit). Other shortcuts to enter edit mode include pressing ALT-P or clicking the left mouse button over the desktop.

The quarter ellipse is only half a tomahawk head, so I simply pressed ALT-C to instantly create a copy of it on the display, then ALT-M to mirror it. Another pop-up menu is displayed, allowing selection of left/right, up/down, or cancel for control. It's a simple matter to mirror it up/down, then slide it under the top half of the tomahawk blade. Next I selected both objects by clicking on each, while I held down the SHIFT key (exactly the same method used to select multiple files in a GEM window in the desktop), then pulled down the arrange menu and clicked on "Right" under the align option.

The two elliptical pies are then lined up at the right edge of their sizing boxes. While both are still selected, pressing ALT-plus (the + key) groups them into a single object. Grouping makes it easy to lock a logical set of objects for moving, copying and sizing. **Easy Draw** always retains the separate identity of each for individual editing if needed.

The next step is to mirror the new object, left/right, to create the opposite edge of the tomahawk.

When drawing objects, it's inevitable that some will overlap. The arrange menu allows you to place selected objects in

front or in back. You can also determine spacing from the arrange menu. You can center objects horizontally or vertically on the page with the center of page option. If you want equally spaced multiple objects, simply select them and execute the "Even Distance Spacing" function.

Alignment can also be done while creating objects, by simply enabling "Grid Snap," which will force all your objects to line up with the nearest grid line. Grid spacing can be set at 1 inch,  $\frac{1}{2}$ ,  $\frac{1}{4}$ , and so on, down to  $\frac{1}{32}$  inch ( $\frac{1}{10}$  inch is included for engineering types).

The page can be specified in inches or metric, portrait or landscape format. The page can be  $8\frac{1}{2}\times 11$  (letter),  $8\times 13$  (legal), or  $11\times 17$  (double) for wide-carriage printers. Similar metric versions are available also, which enable metrically scaled rulers and grids.

Rulers can be toggled on or off, giving you a measurement reference across the top and left side of your active window. The problem with the rulers is that there's no cross hair reference on each ruler (like the small sliders that Publishing Partner uses, or the extended cross hairs of First CADD). Since you have to "eyeball" where you are in reference to the rulers, they won't be helpful in exact placement of objects. Judicious use of the grid and snap features will enable you to create an accurately scaled drawing, using rulers primarily as a quick reference.

**Easy Draw** is flexible and often provides more than one way to achieve an effect. For example, after creating the elliptical pie, I could have pulled down the edit menu and clicked on "Arc/Pie." This allows you to point and click on any object created with the circle or pie drawing tools, and, once selected, its size (from 0-360 degrees) can be adjusted in 5-degree increments with the arrow keys. One-half degree accuracy is possible. To create the opposite edge of the tomahawk, I could have simply rotated the edge or flipped it over.

One of the drawing tools available is a



"polyline," for freehand (or freemouse?) drawing. Even this line is an "object." The line is selected, and the mouse is used to point to any portion of the line. A small square is placed over the nearest point, which can then be dragged anywhere to adjust its contour.

The line menu is a graphic one, allowing you to point to different line types, widths and end types (such as rounded, squared and arrow). Under the pattern menu, shadowing can be enabled for the currently selected object. Objects can be made transparent and pattern styles can be selected. A user pattern can be defined and selected also, with an edit, save and load menu similar to those found in DEGAS and DEGAS Elite.

Color settings can be chosen for lines, fill patterns and text. Since you'll probably be doing all your printing on a simple dot-matrix printer, you'll likely need only one color for everything. The new output program, used for printing pictures, can print your drawings to the screen. It can also be used to create a slideshow of your pictures, where color options might indeed be useful.

When you select "Text Entry" from the pop-up toolbox, you first draw a rectangle and set it on the display. After clicking the right mouse button, a text cursor appears in the top left corner. You may immediately begin entering text, or load an ASCII file. If you load an ASCII file, you are asked if you want to retain all carriage returns, convert them to spaces or reformat your text file to 60 columns as it's loaded. If your text overflows the current box, you can resize it, or position the cursor at the end of the last line that fits and break the text at that point.

Another text box will then appear below the one you're currently editing. This box contains the text overflow, which can be resized and placed elsewhere on the current page, or moved to another page. Because **Easy Draw** is object oriented, it's very easy to position your text column anywhere on the page, and to change the column size by simply changing the size of the text box.

There are two limitations that prevent **Easy Draw** from being called a desktop publishing package. First, while you're entering a box of text, all characters are in the same point size and style. If you want bold or italic, those words must be placed in a separate box. Second, text handling from one column to the next is done manually, building one page at a time. A second window is available for

working on two pages at once, but that's the extent of the text handling features. Future updates for **Easy Draw** will enhance its text capabilities.

Text features include the usual bold, light, italic, outlined and underlined attributes. These can be changed for a selected box of text at any time. Point sizes allowed are 7, 10, 14, 18, 28 and 36. Selecting styles under the text menu sends control to the font selection menu. Unless you have extra fonts loaded, only Swiss will be available.

On the Font Pack #1 disk are Rocky (courier) and HiTech (computer) GDOS fonts. The 24-pin printer driver disk is packaged with an enhanced version of the Swiss font, which takes advantage of the printer's higher print resolution. If you have other GDOS fonts for DEGAS Elite or Paint Pro, they won't do you much good with **Easy Draw**. They can be installed and used as screen fonts, but will not print properly unless you also have printer versions of the same fonts.

You cannot selectively erase portions of an object, the way you can in DEGAS or other paint programs. Once an object is created, you can only resize it, change its line patterns and colors, or delete it. When constructing technical drawings, it is sometimes necessary to create working lines, and later erase portions of them. This isn't easily done with **Easy Draw**.

**Easy Draw** needs some work on its window controls. Whenever you click on the gray areas of the scroll bar to page over to a different portion of the drawing, it moves too far. There's little or no overlap, which can be very frustrating when you're trying to drag an object from one side of the window to another while in normal or zoom modes. Clicking on the window arrows causes scrolling in increments much too small. I've found it much more convenient to become adept at guessing how far a move will be performed by moving the sliders on the scroll bars. (The people at Migraph say that the windows function according to the GEM standards.)

When it comes to copying objects from one drawing to another, **Easy Draw** provides two solutions. You can drag any object to the clipboard, or a second window can be opened. You can then copy objects between the windows just as you would with files from one disk window to another on the desktop.

When your masterpiece is complete, select "Output" from the file menu, and a new desktop will appear as **Easy Draw** ex-

ecutes the output program. A large dialog box will appear, with the name of the last page edited at the top. More names can be added to this list. When you start output, each page will be sent to the printer in the order listed in the table. Pressing ESCAPE will halt output at the end of the current page. **Easy Draw** prints a document much faster than Publishing Partner does, and the final results are impressive.

The support packages for **Easy Draw** are fun to play with. In the Personal Draw #1 package, you'll find an oversized alphabet (which can be resized simply), boats, borders (which are easily grouped and stretched to make all sorts of Print-Shop-style prints), planes, trucks, animals, and many other interesting icons.

The Technical Draw #1 disk contains another object alphabet for starters. You'll also find electronics icons, including diodes, logic gates, resistors, transformers, etc., and standard icons for electrical wiring, pipes and hydraulics. Object files with flowchart symbols, home planning icons (bath, stairs, kitchen appliances, etc.), welding symbols and microcircuits round out this package.

More font disks, laser printer support, and the Super Charger are expected from Migraph. The Super Charger, building on GDOS and its metafiles, will allow you to manipulate DEGAS, Neo-Chrome and scanned images (supporting very high dot densities). The problems that Art Leyenberger mentioned in his review of version 1.1 (the July 1986 **ST-Log** in **ANALOG Computing's** issue 44) have all been addressed and corrected.

The use of the new output program for printing means that **Easy Draw** can support all printers that GDOS supports, a list that's growing rapidly. Picture files are stored only in .GEM format now; the second .EZD file is no longer necessary to store a drawing. The program works fine from hard disk now (loading everything but GDOS, only 8K, and the ASSIGN.SYS, from the hard drive). Liz Mitchell of Migraph helped me, by providing updates for the program and support packages several times during the review process.

Migraph has a fine product in **Easy Draw**, and is obviously committed to supporting it strongly. (Not every product is enhanced sufficiently to warrant two reviews in this magazine!) **Easy Draw** is fast, bug-free, powerful and, most of all, easy to use. I highly recommend it. //

# Inside the ST Xformer

## A SPECIAL INCLUSION

### An Atari 800 software emulator for the ST—Part 1.

by Darek Mihočka

Ever since the introduction of the 68000-based machines—like the Mac, ST and Amiga—we've seen a new type of software emerge: the software emulator. Unlike hardware emulators, which are almost stand-alone computers and have large price tags, the software-only emulator requires no additional hardware and is relatively cheap.

For the ST alone, there's already a significant list of machines emulated through software: CP/M, IBM PC, the Mac, Apple II and Atari 800. Most people who've seen my Apple II and Atari 800 emulators have several questions that I've answered in detail in this article. They want to know how this can be done without any hardware; if other machines can be emulated, too; why it's so slow; and why I called it the **ST Xformer**. The last is easy: *transformer.tos* is too long to be a filename.

This article will focus on the Atari 800 version of the **ST Xformer**. The complete program, including source code is provided on the disk version of this magazine, and is also available from the Delphi Atari Users' Group. Listings were too long for inclusion here. Anyone with a Megamax C compiler can play around with the **Xformer** source code. I hope several readers will emulate new machines, such as the CoCo and the long line of Commodore machines.

But, before we get technical, I'm sure everyone wants to try the emulator first.

#### Running the ST Xformer.

The **ST Xformer** is a software-only simulator (or emulator) of an Atari 800 computer. It works on any ST with a minimum of 512K and a color monitor. It can be used to run most public domain software available for the 8-bit Atari computers, and is compatible with Atari DOS 2.0 files. All you have to do is transfer files from a 5¼-inch disk to the

ST's 3½-inch disk. This can be done by downloading from a BBS, or by using a null modem cable.

On this month's disk is a file called `__XFORMER.TOS` and the four support files described below. Simply double click the TOS file from the desktop in either low or medium resolution, and a title page should appear. Hit any key to actually "boot up." The configuration on the disk is set up so that it boots up as a 48K Atari 800 with BASIC plugged in.

To make up for keys lacking on the ST's keyboard, function keys F7, F8, F9 and F10 are the START, SELECT, OPTION and RESET keys, respectively (the same layout as a 130XE). The ALTERNATE key is used in place of BREAK, F4 is the CAPS key, and F5 is the Atari logo (inverse) key.

The joysticks are supported, with the joystick port being stick 0 and the mouse port being stick 1. For software that makes use of sticks 2 and 3, stick 0 also doubles as stick 2, and stick 1 doubles as stick 3.

If you're in BASIC, you can load and save files from disk using the same commands you normally would on your 8-bit. All drive number references are ignored; you'll go to the directory that the emulator is on. Binary files can be loaded from the DOS menu, but remember that some files require removal of BASIC. It is suggested that two disks or directories be made, one with `__BASIC.CTA` (see below) and one without. Additional directories should be made if other cartridges are copied over.

Since no emulator can possibly be 100 percent compatible with the original machine, I would like to maintain a list of software that *does* work. Anyone who would like to contribute to this list can contact me through **ST-Log**, or on Delphi, CompuServe or GENie at the ID numbers given at the end of this article.

As you'll find out, the emulator runs at about 20 percent of the speed of a real Atari 800. This figure varies from pro-



gram to program, but it's usually in the range of 10 to 50 percent. The reasons for this, and methods that can be used to speed things up, are explained later in this article.

My own list of working tested software now includes: Atari BASIC, Microsoft BASIC, BASIC XL, AtariWriter, PaperClip, MAC/65 and hundreds of public domain programs found on BBSs. Unfortunately, none of the game cartridges, like Pac-Man or Star Raiders, could be made to run.

### Support files.

The support files included are `__ATARI.FNT`, `__ATARI.FP`, `__ATARI.OSB` and `__BASIC.CTA`. Each file must start with an underscore and have the proper extender, but the remainder of the name is up to the user. Each file is in Atari 2.0 DOS binary file format, and the start and end addresses of each file are:

- `__ATARI.FNT` (\$E000 to \$E3FF) ..... Contains the character set.
- `__ATARI.FP` (\$D800 to \$DFFF) .... Contains the floating point package.
- `__ATARI.OSB` (\$E400 to \$FFFF) .. This is the ROM B operating system.
- `__BASIC.CTA` (\$A000 to \$BFFF) ..... Optional, left cartridge.
- `__*.CTB` (\$8000 to \$9FFF) ..... Optional, right cartridge.

The first three files, which make up the operating system, must be present for the emulator to function. The reason for breaking up the operating system into three files is that it makes it easier to custom tailor one's operating system using other character sets or floating-point packages. For example, you may choose to use the Fastchip floating point package which is provided on the disk as `__FASTCHP.FP`.

If either one of the cartridge files are found, that cartridge will be executed. Otherwise, a DOS-type menu will appear. Allowable commands are:

- A ..... Get a disk directory (hit SPACE BAR to pause).
- B ..... Run the cartridge.
- L ..... Load and execute a binary file.
- M ..... Run at an address.
- P ..... Enter the 6502 monitor.
- Q ..... Quit to the desktop.

The first four commands are similar to their counterparts in DOS 2.0.

### 6502 monitor.

Since the Atari 800 does not have a built-in machine language monitor (like that found on the Apple II), I have provided one in the **Xformer**. To enter it, hit `P` from the DOS menu, then hit `HELP` to get a command summary. This monitor has the advantage of occupying no memory in the virtual computer, as well as allowing you to step and trace through any code, even ROM.

The monitor may occasionally have to be used to patch up a binary file that doesn't run. For example, the program may try to access a hardware register not supported on the emulator, and end up stuck in an infinite loop. Usually, NOPping the code will do the trick. Also, machine language timing loops can be shortened to increase speed.

As is the case with most binary files, you usually have to reboot the computer to load another one. This can be done by either rerunning the **Xformer**, or by just using the `B` command in the monitor, which simulates a coldstart.

### Designing the emulator.

Here's the technical part; get out your 68000 manual!

The emulator is written in Megamax C with in-line 68000 code. I chose Megamax because of its in-line code feature, which allows fast development of a program in C, followed by later optimization in assembler. However, it should not be difficult to transfer the source code to another C compiler or even to the Amiga, since most of the code is not machine specific. I used overlays, so there's no need to worry about Megamax's 32K code size limit.

The following discussion assumes a fair understanding of the Atari 800 operating system and hardware, from a programmer's point of view.

There are four source files associated with the emulator: (1) `__XFORMER.H` contains constant and global declarations; (2) `__XFORMER.C` contains all of the code for the DOS menu, the title page, the ROM loaders, and other miscellaneous; (3) `__X6502.C` contains the 6502 interpreter; and (4) `__XATARI.C` contains all the Atari-specific hardware routines.

Before we continue, I would like to mention that I did not use the Megamax editor to create these files. I used a keyboard-based editor that did not support real tabbing, so all tabs are expanded to spaces. Also, the Megamax editor is limited to text files no greater than 32K in length. All three `.C` files fail there!

A computer such as an 800XL or Apple II contains several thousand bytes of RAM, several thousand bytes of ROM on which the operating system is usually stored, and some supporting hardware which generates the video display and sound, and performs I/O. A virtual computer performs all these functions through software. Therefore, an emulator is a collection of subroutines, which simulate the operation of the real hardware.

Since the ST has a minimum of 512K, we can be liberal about allocating memory, especially if this helps speed up the emulator. However, because space on the disk is limited, the source code has been written to put as many common pieces of code into subroutines as possible. This results in a small speed loss, which can be regained by simply expanding the subroutines.

The necessary initialization and allocation is in the file `__XFORMER.C`. The pointer `scr` is initialized to the starting location of the ST's screen. Since the emulator requires an additional 160K or so of memory, it is allocated downward from this location. The 32K block of memory immediately below the screen is pointed to by `scr__emul` and is used to store the image of the emulator's video screen.

Recall that an 8-bit computer usually has an addressing range of 64 kilobytes. Therefore, we need to allocate a block of memory 64K in length. This is done in `main()`, and the pointer to the block is `mem`.

This would be sufficient for a straight 6502 emulator, which assumes 64K of RAM. However, since the Atari 800 has many different types of memory locations (ROM, RAM, screen, hardware registers, etc.), an additional block of 64K must be allocated to keep track of this information. This block is pointed to by `stat[]`. Note that `stat` points to the middle of the block, not the beginning, to take advantage of the indexed addressing mode on the 68000.

The following map shows the memory allocation:

32K Screen Memory	end of RAM
32K Virtual Machine Screen Output Memory	scr
64K Virtual Machine Main Memory	scr__emul
64K status bytes for Main Memory	mem
free memory	stat
8K stack, accessed by A7 contains local variables, accessed by A6	stat-32K
32K static storage (globals) accessed by A4	
base page, code and text segments and low memory	

To simplify conversions between a 6502 address and a real address in the ST, mem is made to point to a 64K boundary. This way, the upper 16 bits of the address are constant, and the lower 16 bits are the 6502 address.

In addition to the RAM and ROM, there are a few bytes of memory on the 6502 microprocessor, known as "registers," which contain important variables that must be kept track of. The emulator simulates these registers by using the 68000's eight data registers. The mapping is shown below, along with the defined names of the registers:

- the instruction register (IR) stored in D0 (IR and DBUS)
- D0 also serves as the "data bus" for read operations
- the accumulator (REGA) stored in D1
- the X and Y index registers stored in D2 and D3
- the stack pointer (REGSP) stored in D4
- the program counter (REGPC) stored in D5
- the status register (REGST) stored in D6
- the "address bus" address calculations are performed in D7 (REGEA)

The four available address registers, A0 through A3, are also used and given the names REGMEA, REGOPS, REGMPC, and REGSTAT. REGMEA is a duplicate of what is stored in REGEA. This gets around the 68000's limitation of not allowing data registers to access memory directly. REGSTAT contains the value of the pointer stat and is used for speed. REGOPS points to the vector table discussed below, and REGMPC is a duplicate of REGPC to get around the same 68000 limitation mentioned above.

I gave the registers names because the code is a lot easier to follow than one full of A0s and D0s.

### 6502 simulation.

To understand how the emulator works, one must understand what sequence of steps a real microprocessor goes through when executing a program. A typical sequence is as follows:

- (1) Fetch a byte of memory pointed to by the program counter (PC) and store it in an internal register called the Instruction Register (IR).
- (2) Increment the PC to point to the next byte of memory.
- (3) The instruction stored in the IR triggers the controlling circuitry in the microprocessor to execute one of the 256 possible instructions, whether it be an add, load, store, etc.
- (4) If a value must be read from memory, its address

is calculated. This address is known as the effective address (EA). The EA is passed to the memory controller, which fetches the byte and puts it on the microprocessor's data bus. From there, it is loaded into the appropriate register.

(5) If a value must be written to memory, the EA is calculated and the value is put on the data bus. Then, the memory controller is passed the information and the byte is stored in memory.

(6) When an instruction has finished executing, the next instruction pointed to by the PC is loaded, and the cycle repeats.

One possible way of implementing this in software is shown in the following pseudo code:

```

LOOP
  IR = byte pointed to by PC
  if IR=0 then execute code for instruction 0
  if IR=1 then execute code for instruction 1
  if IR=2 then execute code for instruction 2
  .
  .
  .
  if IR=254 then execute code for instruction 254
  if IR=255 then execute code for instruction 255
  increment PC
ENDLOOP

```

Unfortunately, when I implemented this in C, it ran at about 1 percent of the speed of a real 6502. Obviously, a better method had to be found. Since the control circuitry of a microprocessor generates the control signals at the same time it reads the instructions—not sequentially, as in the example above—a method using a jump table gets the job done much more quickly, as follows:

```

variable OPTABLE : array [0..255] of pointers to functions
/* initialized to point to the 256 instruction routines */
LOOP
  IR = byte pointed to by PC
  jump to REGOPS[IR]
ENDLOOP

```

In the emulator, the table of pointers to functions is defined as follows:

```

extern
  op00(), op01(),
  .
  .
  .
  opFE(), opFF() ;
int (*vec__6502[256])() = {
  op00, op01, op02, op03, op04, op05, op06, op07, op08,
  .
  .
  .
  opFF };

```

The extern tells the compiler that the 256 instruction simulation routines, called op00 through opFF, will not be found as C functions in the current file, and are instead found in another file which contains 256 assembly language functions. This must be done to keep the Megamax compiler happy. Once that is established, the variable vec\_\_6502 is defined to be an array of pointers to the functions. In fact, this is simply an array of 32 bit addresses, which is 256 \* 4 = 1024 bytes long.

Since the addresses are 32 bits (4 bytes) long, the offset into the array must be IR \* 4 bytes. Therefore, when the IR is fetched, it must be shifted 2 bits to the left (multiplied

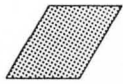

by 4) to calculate the location of the IRth array entry. An indirect jump is then made through the address stored in the array entry. The 68000 code I finally used for doing this is quite short, as the following few lines from the file \_\_X6502.C show:

```
emul:
  clr.w   IR                ; clear "instruction register"
  move.b  (REGMPC)+,IR      ; fetch an opcode
  add.w   IR,IR             ; multiply by 4
  move.l  0(REGOPS,IR.w),REGMEA ; calculate addr of opcode handler
  jmp     (REGMEA)          ; and jump to it
pemul:
  dc.l   0                  ; pointer to emul, exit__emul,
                          ; or sysvbl
```

The routine at emul is called a "dispatcher," since it determines which of the 256 opcode simulation routines is appropriate, and calls it.

To return back to emul, the pointer at pemul contains the address of emul. The code for doing this is in \_\_XFORDER.H and is defined as the macro DISPATCH. The reason a simple branch statement is not used is explained in Part 2 of this article (next month's **ST-Log**), in the hardware simulation section.

Let's take a detailed look at how some of the 6502 instructions are simulated. Of the 256 possible opcodes, about 100 of them are not defined. In the emulator, they are simply treated as NOPs (No Operation) and perform no function. They are easy to simulate. For instance, the opcode \$EA:

opEA: DISPATCH

Thus, the only function of the NOPs is to jump straight back into the main loop of the emulator.

To take a more complex example, let's look at opcode \$A5, which is the LDA zero page instruction:

```
; LDA zp
opA5:
  clr.w   REGEA            ; clear effective address
  move.b  (REGMPC)+,REGEA  ; get low byte of address
  move.l  REGEA,REGMEA     ; put into an address register
  move.b  (REGMEA),REGA    ; read the byte into accumulator
  move.w  SR,DBUS         ; get stats flags
  and.b  #(BITN|BITZ),DBUS ; mask out N and Z
  and.b  #~(BITN|BITZ),REGST ; clear old N and Z
  or.b   DBUS,REGST       ; and stuff in the new ones
  DISPATCH                                ; go do next instruction
```

First, the 16-bit effective address is cleared. Then the low byte of the address is fetched from the next byte pointed to by the PC. Since this is a zero page instruction, there's no need to load a high byte; it was already cleared to zero. Now the actual load from memory is performed, to set the 68000's N and Z flags. These are moved from the status register to DBUS, masked out, and put into REGST (the 6502 status register). Then DISPATCH returns us to emul.

Almost every opcode is interpreted in a similar way. Most of the opcode routines call some common code, like doLDA, which does the extraction of the status flags. This saves code space, but introduces an extra branch.

Generation of the effective address for absolute addressing modes was more difficult to implement. This is because a 6502 stores its 16-bit addresses in low-byte/hi-byte format. A 68000 stores its 16-bit numbers in hi-byte/low-byte format. In addition, the SWAP command does not work on two 8-bit values, just on 16-bit values. A quick way had to be found to swap 2 bytes.

The following code is the fastest way of doing the swap (I think), shown for opcode \$AD, the LDA absolute instruction:

```
; LDA abs
opAD:
  move.b  1(REGMPC),-(SP) ; get and push the high byte
  move.w  (SP)+,REGEA     ; pull it as a word
  move.b  (REGMPC),REGEA  ; fill in the low byte
  addq.w  #2,REGMPC       ; increment PC by 2
  bra     doLDAchk
```

The trick is to read in the high byte of the address first, push it to the stack as a byte, and pull it as a word. This works because of the inability of the 68000 to push a byte onto the stack. It always pushes a word. If you tell it to push a byte, it does so, but then pushes another byte of garbage. When the stack is popped as a word, the original byte is now loaded first, right into the high byte of the word in REGEA. The low byte is then read, which also clears out the garbage byte. This takes six clock cycles less than the more logical code, due to the fact that large shifts are very slow on the 68000:

```
; LDA abs using slower code
opAD:
  move.b  1(REGMPC),REGEA ; get the high byte
  lsl.w  #8,REGEA         ; shift it over 8 bits
  move.b  (REGMPC),REGEA  ; fill in the low byte
  addq.w  #2,REGMPC       ; increment PC by 2
  bra     doLDAchk
```

As can be seen, it's not too difficult to simulate any of the 256 opcodes. Most have the same format: calculate an effective address and jump to a common routine which then performs a memory read or write and updates the flags.

The "flags" are really just one of the data registers, called REGST, being used to represent the status register of the 6502. When an opcode like ORA executes, the status bits of the 68000 are set. These are then copied to register D0, and unnecessary bits are ANDed out. Similarly, bits to be updated in REGST are ANDed out, and the two registers are ORed, so that flags in REGST are updated.

One may notice that the status bits of a 6502 and a 68000 are different in some cases. A 6502 has the decimal, break and interrupt flags unique to it, while the 68000 has the extended carry flag and 3 unused bits. By combining the used bits of each microprocessor together, one ends up with 8 status bits: N V C X B D I and V. These 8 bits are used in REGST. The problem was which format to use, the 6502 or the 68000. The final decision was to use the 68000 format of the status register. A bit scrambling routine in the execute() routine rearranges the original contents of the 6502 status register into the 68000 format. When exiting back to the monitor, another routine rearranges the bits back to 6502 format, ignoring the X bit.

### Step and trace.

One feature of the emulator is that it can execute the 6502 code continuously or one opcode at a time. One of these is chosen with the S command of the monitor. I had to find a way to stop execution at any time, without introducing too much overhead code into the main loop.

Luckily, I discovered a way to do this with no overhead code. Since pemul already points to the main loop, it can just as easily be made to point to the emul\_exit routine, which returns back to the monitor. I do this by checking the



trace flag which is set by both the T and S commands. If trace is on, REGEMUL is loaded with the address of the exit routine; otherwise, the address of the main loop is loaded. This way, the main loop can be made to execute once and return back to the monitor.

### Debugging problem software.

As I've stated, the Xformer is not 100 percent compatible with an Atari 800. Some software will appear to crash when run on the emulator (it usually won't get past the title page). A common reason for this is that, after the program draws a title page, it may wait for some event to occur before proceeding. This event may be an interrupt generated by the POKEY chip, or another hardware location not supported on our emulator. The Xformer thinks the event has not occurred, so it stays in the title page. The CES demo (walking robot and spaceship) is one such program.

To find these problems, I have made the F1 key a "break" key. When it's hit, the 6502 interpreter stops and exits to DOS or the monitor. If you then enter the monitor and hit T to trace at the current PC location, the traced code will probably look like this:

```
LDA some location
BNE to the LDA
LDA
BNE
LDA
BNE, etc.
```

At that point, use the : (colon) command of the monitor to NOP out the branch statement. Then continue execution with the G command, and the program should work.

Another problem, harder to track down, crops up when an event which should change the value of the PC does not occur. An example is the BASIC XL runtime package. To coax it into working, load it from DOS and wait for it to "crash." Then hit F1 and RUN AT ADDRESS \$5000.

The majority of software tested runs without any modification. If you find a problem and a fix, let me know; I'll post patches on Delphi, CompuServe or GENie.

### Speed.

If you count clock cycles required to execute just the dispatch routine, you get about 50. Add another 20 to 100 to simulate an opcode, for an average time of 120 clock cycles. On an 8MHz 68000, this translates to about 15 microseconds. Compared to a 6502, where the average opcode takes 4 microseconds to execute, we see that the emulator will average about one-quarter the speed of an Atari 800. This does not take into account the extra time required to emulate all the hardware, as discussed next month in Part 2. Atari's CP/M emulator manages more speed because a CP/M machine has no special hardware to simulate. Until the ST becomes more powerful—through a 68020 upgrade—real-time emulation will be impossible.

Next month, we'll continue our discussion of software emulation, and the techniques used in the development of the ST Xformer will be further explored. //

Darek Mihocka is a co-op Computer Engineering student. Between his school terms, he works at Microsoft Corporation in Seattle. On Delphi and GENie, he's DAREKM; his CompuServe number is 73657,2714.

## POLYDISK ST

The highly acclaimed POLYDISK is now available! This simple plug-in cartridge provides **512K of extra memory** that can be used as a RAM DISK, Print Spooler, Cartridge Emulator, and more. Works with all ST models, even 1 meg owners benefit. It won't void your warranty — simply plug it into the cartridge port and it's ready to use. Polydisk is **reset-proof**, your work is safe even after hitting system reset. Great for programmers, business people, or anyone who needs the incredible speed of a RAM Disk, and the time saving convenience of a print spooler.

**POLYDISK 512K RAMdisk/print spooler cartridge ONLY \$199.95**

**POLYDISK Battery Back-Up Option** maintains Polydisk memory even after a power failure. Self charging. Memory intact even after 5 hours. **\$39.95**

**POLYDISK Clock Option** adds a clock/calendar board with replaceable 3 year battery. **\$29.95**

The world's most inexpensive clock cartridge. Finally its affordable to keep your time and date accurate. 3 year battery included. **ONLY \$24.95**



## COLOR COMPUTEREYES™

Incredible COLOR video digitizer.

- The first and only full color digitizer for the ST. • Uses standard video inputs like video camera, VCR, or video disk.
- Works in all ST resolutions. Low res provides 16 shade black and white or full color pictures. • Pictures can be used with Degas, Neochrome, Powerprint and others. • Automatic calibration of contrast, brightness and white balance. • Plugs into cartridge port for easy set-up. • Capture your picture or that of your favorite star. **ONLY \$199.95**

**SPECIAL OFFER** — Buy both Computereyes and Powerprint and SAVE 20.00 from the total.

## PowerPrint ST BLOW YOURSELF UP

Imagine your picture on a 6 foot poster. Create a business graph that can cover a wall. Quality output for posters, t-shirts, news letters, and more. **POWERPRINT**

Whether it's a photo digitized with ComputerEyes, a masterpiece created with Degas, or the winning screen from your favorite game, POWERPRINT can print it with unequalled clarity and resolution. PowerPrint supports **ALL ST resolutions**. It prints multiple sizes up to **GIANT WALL SIZED POSTERS**. Print to shades for incredible detail. Print the whole screen or **ZOOM** in on just the part you want. POWERPRINT offers unique effects, including **rotate, mirror, and inverse** options. Selective shading option allows you to print **multi-color pictures** on any printer by printing one color at a time (using color ribbons). PowerPrint lets you capture and print almost any ST screen. Works with Star, NEC, Citoh, Gemini, EPSON, XM8048 and compatible printers. **ONLY \$39.95**

## PROGRAMMERS WANTED

Alpha Systems pays some of the best royalties in the industry. If you program on the ST, contact us about the opportunities we can offer.

## Digisound ST

Incredible ST sound. Now your ST can speak in any language and play the sounds of a whole orchestra. Digisound lets you record, manipulate, and play sounds in their pure digital form. Digisound plugs into the cartridge port and accepts sound from a microphone, radio, tape recorder, CD player, or TV. Add special effects like reverb, sound merge, looping, invert and echo. Play the sounds back through your monitor speaker, or hook it up to a high quality sound system. Digisound by Alpha Systems was used to create the voice in "ChessMaster 2000™", and other professional programs. Use it as a voice synthesizer, a musical instrument or a special effects generator. Digisound makes it easy to add professional sound and voice to your own programs. Record, play, analyze and manipulate sounds using the power of your ST and easy mouse control. **ONLY \$89.95**

Call or write for our **FREE CATALOG** explaining our full line of ST and 8-bit products.  
**Customer Service line**  
**(216) 467-5665**  
 9am-3pm EST M-F



**24 HOUR HOTLINE | 216-374-7469**

**ALPHA SYSTEMS 1012 Skyland, Macedonia, OH 44056**  
 Include \$3.00 shp. & hdlg. (US & Canada). Ohio residents add 5 1/2% sales tax. Foreign orders add \$8.00 shp. & hdlg.

— VISA & MasterCard  
 Order by phone or send check or money order to:

# YOUR ATARI 520ST SUPPORT CENTER

<b>ABACUS</b>		Atari 520 ST Mono System	Call		
Paint Pro	33	Atari 520 ST Color System	For		<b>PRINTERS</b>
Text Pro	33	Atari SF 314 Disk Drive	Best		
Data Trieve	33	Atari SH 204 Hard Drive	Price		
Powerplan	54	Atari Hardware			<b>STAR MICRONICS</b>
PC Board Designer	139				NP-10 179
Assem. Pro	43				NX-10 229
Paint Pro Data Lib.	21				<b>PANASONIC</b>
Fourth H/T	33				KX-P 10801 199
<b>ACADEMY</b>		<b>BECKEMEYER</b>	<b>MICHTRON</b>	<b>QUANTUM</b>	KX-P 10911 259
Typing Tutor/		Micro C-Shell 39	DOS Shell 26	ST-Talk 14	KX-P 3131 259
Word Invaders	23	Micro C-Tools 19	The Animator 26	QUICKVIEW	KX-P 1592 399
<b>ACCESS</b>		Micro Make 27	Personal Money Mgr 33	Zoomracks II 99	KX-P 1595 579
Leaderboard Golf	26	RTX 53	Utilities 39	REGENT	KX-P 10921 329
Tournament Disk	14	Micro MTC Shell 99	M-Disk 26	Regent Spell 34	<b>MODEMS</b>
Tenth Frame	26	Hard Disk Accelerate 30	Softspool 26	Regent Base 67	Supra 300 ST 59
<b>ACCOLADE</b>		Ansiterm 27	Flip Side 26	Regent Word II 67	Supra 1200 ST 149
Mean 18 Golf	29	Hard Disk Tool Kit 23	Calendar 19	SHANNER	Avatex 1200 99
Sundog	26	<b>CENTRAL POINT</b>	Mi-Term 33	Soundwave SW-1 15	Avatex 1200 HC 129
Mean 18 Course Dsk	14	Copy II 26	Time Bandits 26	ST-Key 10	Compuserve Start Kit 24
<b>ACTION</b>		<b>DAC</b>	Cornerman 33	Macro-Manager 15	Microstuffer 59
Action Pak	28	Easy Accounting 47	Mighty Mail 33	Macro-Desk 10	Omega Terminal 20
Solapak	28	Easy Payroll 33	Cards 26	DB Calc II 15	Atari 301 Modem 49
<b>ACTIVISION</b>		<b>DATAPACIFIC</b>	Business Tools 33	Colorwriter 10	
Mindshadow	33	Magic Sac 119	Major Motion 26	SHELBORNE	<b>ST ACCESSORIES</b>
Borrowed Time	33	<b>DATASOFT SOFTWARE</b>	Mi-Dupe 20	Pool 23	Disk Cleaning Kit 14
Hacker	29	Pro Football Wizard 25	BBS 2.0 54	Shuffleboard 20	Dust Covers 7
Music Studio	39	Pinball Factory 27	Pro Football Wizard 25	SIERRA	Monitor Stand 12
Paintworks	47	Your Finance Future 26	Mi-Print 20	Kings Quest II 33	Ultima II 20
Little Comp. People	33	ST Protector 22	Trivia Challenge 27	Winnie the Pooh 17	Shanner Planner 29
Hacker II	33	ST Karate 22	GFA Basic Compiler 54	Black Cauldron 26	The Easel 14
Tass Times/Tonetown	29	<b>ELECTRONIC ARTS</b>	Trm Base 69	K/Q Hint Book 6	Disc Directory 20
Champ. Basketball	29	Financial Cookbook 34	Match Point 27	B/C Hint Book 6	Pocket Pak 10
Shanghai	29	Ultima III 15	Raid 27	Donald Duck 17	The Library 34
Champ. Baseball	27	Coloring Book 39	Super Directory 27	Cash Disbursements 67	Flip N File Micro(25) 6
Champ. Football	29	Golden Oldies 23	GFA Basic Interpret. 54	Space Quest 33	Flip N File " (50) 17
<b>AMTIC</b>		Arctic Fox 29	Tech Mate 26	Kings Quest III 33	Flip N File II (40) 20
C.O.L.R. Obj. Editor	23	Skyfox 33	Perfect Match 26	Kings Quest I 33	Flip N File Micro (5) 2
Maps & Legends	27	Starfleet I 32	Space Shuttle II 26	SOFTLOGIK	Flip Sort Micro (50) 7
Macro Assembler	60	Ogre 29	<b>MICRODEAL</b>	Publish. Partner 99	
Lattice C	114	Quizam 25	Karate Kid II 29	<b>SPECTRUM HOLOBYTE</b>	
Disk Doctor	23	Chessmaster 2000 33	<b>MICROLEAGUE</b>	Gato 27	<b>ST BOOKS</b>
A-Calc	45	<b>EPYX</b>	Baseball 39	SPINNAKER	Atari ST GEM Reference
Meta Pascal	75	Winter Games 26	Baseball 39	Homework Helper:Math 34	Atari ST Internals
CAD-3D	37	Rogue 26	<b>MICROPROSE</b>	Treasure Island 27	Atari ST Machine Language
A-Ram	15	Temple of Apshai 26	Silent Service 26	SPRINGBOARD	Atari ST Tips & Tricks
A-Seka	27	World Games 26	MI-GRAPH	Certificate Maker Call	Atari ST from Basic to C
GST C Compiler	60	Champion. Wrestling 26	Easy Draw 52	SSI	Atari ST Basic Training
GST-ASH	45	Super Cycle 26	Fast 33	Phantasie 26	Atari ST Ggraphic & Sound
Expert Opinion	75	<b>FIREBIRD</b>	Harrier Strike 33	Phantasie II 26	Atari ST Logo
Flash	28	The Pawn 29	<b>MINDSCAPE</b>	Flight Simulator 35	Atari ST Peeks & Pokes
Star Struck	19	Starglider 29	Brataccus 33	TDI	Atari ST for Beginners
Red Alert	19	<b>FIRST BYTE</b>	S.D.I. 33	Modula-2 75	
Kermit & Remote Co.	19	Kid Talk 32	Balance of Power 33	Modula-2 Develop.Kit 99	All books are \$16 ea.
Crystal	19	Speller Bee 32	<b>NAVARONNE</b>	UCSD Pascal 59	<b>CABLES</b>
Fonts, Primitives	19	Math Talk 32	Astrology 29	<b>TIMEWORKS</b>	ST to Printer 15
Cartographer	27	First Shapes 32	Timekeeper 34	Datamanager 53	ST to Modem 15
G.I.S.T.	27	<b>HYBRID ARTS</b>	<b>OSS</b>	Swiftcalc 53	
K-Switch	27	EZ Track 39	Personal Pascal 50	Wordwriter 53	<b>COVERS</b>
K-Resource	38	CZ Android 59	PROCO	UNISON WORLD	130XE Computer
Rambrandt	15	<b>LOGICAL DESIGN WORKS</b>	Pro-Copy 24	Printmaster 26	800XL Computer
A-Chart	30	LDW Basic Compiler 47	<b>PROGRESSIVE COMP. AMPL.</b>	Art Gallery I 19	1050 Disk Drive
<b>ARTWORK</b>		<b>MARKSHAN TECHNOLOGY</b>	Graphic Artist 132	Art Gallery II 19	520ST Computer
Bridge 4.0	19	Phaser 69	Font Editor 54	VIP	SF354 Disk Drive
Compubridge	19	<b>MASTERTRONICS</b>	Font Pak I 34	VIP Professional 149	SF1224 Color Monitor
Mailist	14	Renegade 14	Desktop Publ. Lib. 34	VIP Lite 69	SM124 Mono Monitor
Strip Poker	25	<b>MEGASOFT</b>	<b>PROGRESSIVE PERIPHERALS</b>	X-LENT	1040ST Computer
Peggamon	12	A Copier 27	Picasso's Revenge 40	Typesetter Elite 29	
Hole in One Golf	19	X-Rated Library 17	<b>PSION</b>	Rubber Stamp 25	
<b>ATARI</b>		<b>OTHER:</b>	Chess 39	Music Box 32	
DB Man	99	Certificate Maker 33	<b>PSYGNOSIS</b>	Megafont 25	
DB Master	33	Psion Chess 39	Deep Space 34	Write 90 Degrees 19	
Joust	19	Microleague Baseball 39	Arena 26	PM Interface 19	
Star Raiders	19	Aegis Animator 54		Typeset Color Icon 13	
Crystal Castles	19				<b>CALL</b>

To order call TOLL FREE

# 1-800-824-7506

ORDER LINE ONLY

## COMPUTER CREATIONS, Inc.

P.O. BOX 493 - DAYTON, OHIO 45459

For information, order inquires, or for Ohio orders (513) 435-6868



Order lines Open 9:00 a.m. to 8:00 p.m. Mon.-Fri.; 10 a.m. to 4:00 p.m. Sat. (Eastern Standard Time). Minimum \$15 per order. C.O.D. (add \$3.00). Please specify computer system. Call toll free number to verify prices and availability. Prices and availability are subject to change without notice. We ship C.O.D. to Continental U.S. addresses only! Please include 4% shipping on all Hardware orders (min. \$4.00). Software and accessories add \$3.00 shipping and handling in continental U.S. Actual freight will be charged outside U.S. to include Canada, Alaska, Hawaii, Puerto Rico and APO. Ohio residents add 6 1/2% sales tax. Canadian orders add 5% shipping, (min. \$5.00). All other foreign orders, please add 15% shipping. (min. \$10). For immediate delivery send cashier's check, money order or direct bank transfers. Personal and company checks allow 3 weeks to clear. School purchase orders welcome. Due to our low prices, all sales are final. NO CREDITS. All defective returns must have a return authorization number. Please call (513) 435-6868 to obtain an RA# or your return will not be accepted for replacement or repair. FOR YOUR PROTECTION WE CHECK FOR CREDIT CARD FRAUD. We do not bill until we ship.

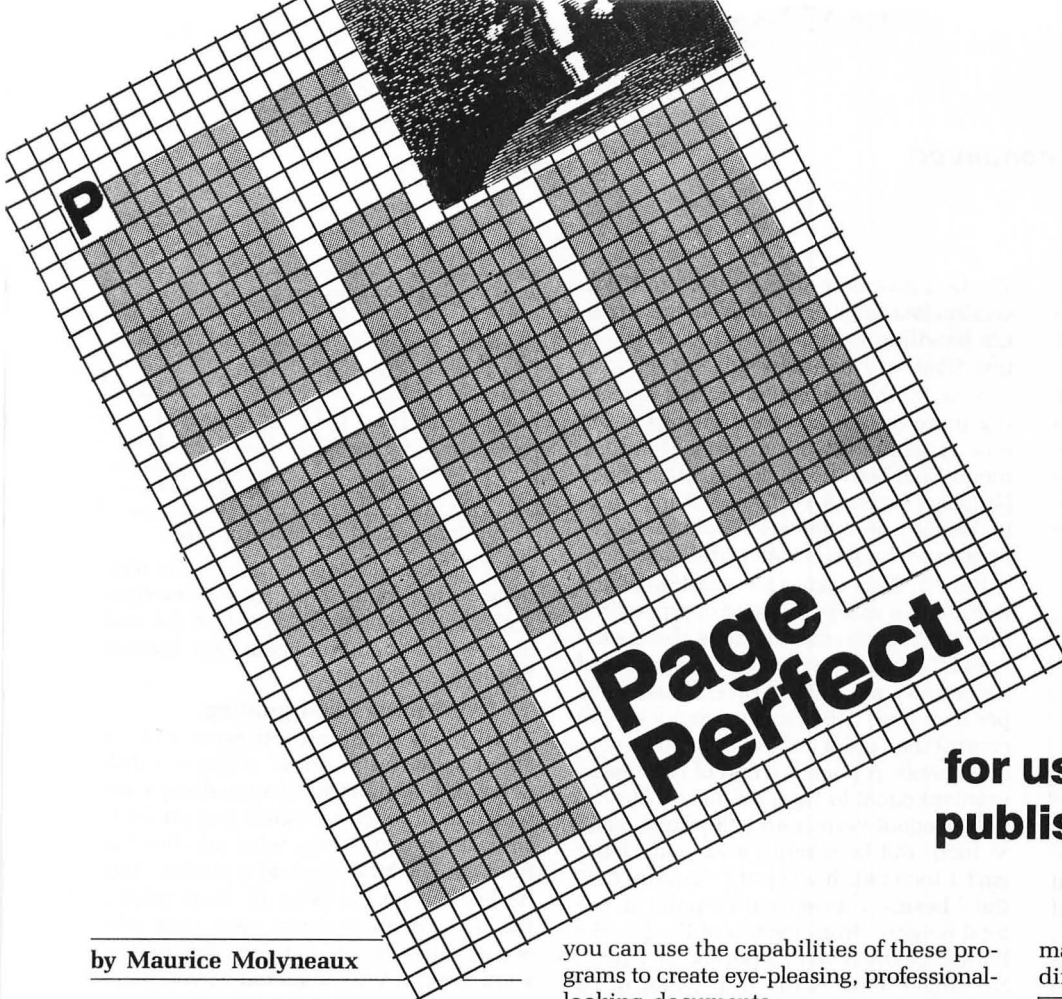

## Effective page design for users of desktop publishing software.

by Maurice Molyneaux

To say that the field of desktop publishing has grown quickly in the past few years would be as much of an understatement as saying "Hitler caused a little trouble in the 40s." Suffice it to say that the desktop publishing field has fairly exploded. Programs, support utilities and fonts for desktop publishing are spreading faster than juicy rumors. Few computers remain untouched by the flood, and most of those will be inundated before long.

Why is this? Simple. A good desktop publishing system puts in the hands of an average person the power to produce documents, flyers, etc., of a quality surpassed only by professional typesetting equipment. With a computer, printer and appropriate software, you can crank out newsletters, advertisements, reports, manuals, and more, with integrated text and graphics, multiple fonts and text styles. In essence, you can have a small publishing house right in your very own den!

Desktop publishing (which we'll call DP from here on) differs from word processing, in that the end product of a DP program is considered "camera ready," meaning that a printer can photostat it as is for reproduction. If you produced such a document on a word processor, the printer would have to have it retyped on a typesetting machine, so that the document would look "professional."

In this article, I'll explain some of the features common to DP software and how

you can use the capabilities of these programs to create eye-pleasing, professional-looking documents.

Before we start, I'd like to thank the fine people at SoftLogik Corp. for providing me with a copy of their Publishing Partner program, which was used to create all the example pages appearing in this article.

### Of fonts and attributes.

According to the *Random House Dictionary*, a *font* is a "receptacle for the water used in baptism." Funny, I can't see what that has to do with printing. Oops . . . I see; the *second* listing defines it as "a complete assortment of type of one style and size." Much better.

Fonts are important in the world of printing. Lettering styles can enhance or diminish the visual impact of your documents. If you were printing an advertisement for a medieval "faire," you would probably want to use a traditional, ornate typeface for the text rather than a hard-edged digital style. Or, if you were printing the program schedule for a science fiction convention, you would be better off using a sleek, futuristic font than one spilling over with stylish *serifs* (a serif is a small cross-stroke used to finish a main stroke of a letter, as at the top and bottom of a capital *I*). A lot of people don't understand the significance of all this. Use of an inappropriate font is like having Beethoven's *Pastorale* as the theme music in a break-dancing movie. They just don't work together (in fact, the very *idea*

makes me queasy). Figure 1 illustrates the differences between several fonts.

Courier  
**Courier Bold**  
 Helvetica  
 Avante Garde  
 Times Roman

Figure 1. — Some common typefaces.

Any DP program worth the disk it's on allows the user to select from multiple fonts, even to mix fonts within the same document. Unfortunately, a lot of the programs require the fonts used in a given file to be on the *same disk* as the document file you've created. If you saved your document to a disk other than the one containing the fonts, you'll probably have to quit the program, copy the document to the disk with the fonts (or vice versa), then rerun the DP software. An annoyance, to be sure!

Still, a font is just a font. To add *emphasis* to words or phrases, you need to be able to **alter** attributes of a given font. What is an attribute? Look at the previous lines. Emphasis is given via italics and bold type—on a computer, by underlining—or a combination of these characteristics. Such variations are known as "attributes" in typography (the study of type, *not* the science of typographical errors).



Attributes can go far beyond simple italics and boldface. You can slant text to the left (known as a "backslant"), make it light (faint), tall, upside down, outlined, reversed (inverse), and so on. Not every DP program offers every attribute, but the good ones usually cover themselves pretty well in this regard. Figure 2 displays a number of attributes. In most cases, these can be mixed—you could have bold, italic, outlined, upside-down text!

Normal	<b>Reverse Type</b>
Backslant	<b>Shadow</b>
<b>Bold</b>	<del>Strike Through</del>
<u>Double Underline</u>	Tall
<i>Italicize</i>	<u>Underlined</u>
Light	ŋb2!q6 D0M u
Mirror ɹ0ɹɹ!M	<b>Wide</b>
Outlined	

Figure 2. — Attribute samples.

Like fonts, attributes have their place. You shouldn't change attributes hither and yon, because, while they can and do add extra punch to your text, they only do so when used *judiciously*. Do not overuse them. If you do, your document will be a collage of typstyles. The reader will assume you either couldn't make up your mind or are just plain nuts (probably the latter). I've said it over and over in the past, but it bears repeating: "Nothing exceeds like excess."

As with any rule, there are always exceptions. There *are* instances where the

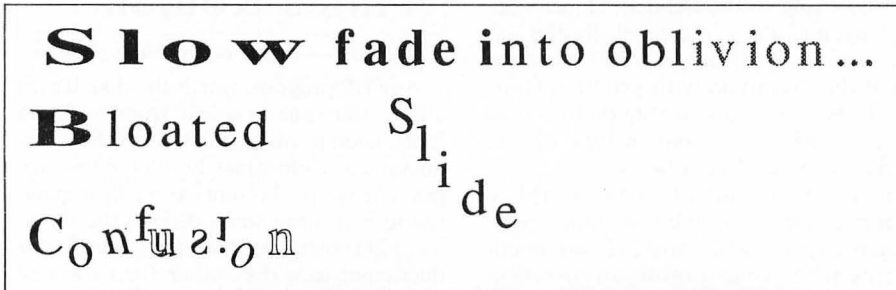

Figure 3. — Attributes used for a special effect.

changing of attributes many times in sequence can be used to obtain a specific effect. Figure 3 gives a clear example of such uses of attributes to add significant emphasis.

Note the way the gradual lessening of letter thickness and darkness heightens the impact of the words *Slow fade into oblivion . . .*, and how the wide, bold *B* gives weight to *bloated*. The staggered letters of *slide* visually convey that word, and see how the jumble of attributes and use of super- and subscripts makes the word *confusion* look really confused! The ex-

amples I give here are best used in titles, section headings, etc. Such severe attribute handling would be difficult to do in text (and still have it readable).

Now, for those of you interested in reading more on the interrelationship of letters, typography and graphics, I recommend Elizabeth Resnick's excellent book *Graphic Design: A Problem-Solving Guide to Visual Communication*, published by Spectrum Books/Prentice-Hall Inc.

Finally, there comes the question of text size. With a word processor or typewriter, the best you can usually do is change the "pitch" of the type (that is, the spacing of the letters), as in 10, 12 or 17.5 characters per inch (cpi). DP systems usually let you control the "point size" of the text in your documents. A *point* is a unit of type measurement equal to 1/2 of an inch. Thus, 36 points equal 1/2 inch and 18 points equal 1/4 inch. But be careful: a 72-point letter isn't 1 inch tall; if you put a 72-point capital *I* beside a lowercase 72-point *p*, the total height—from the top of the *I* to the bottom of the *p*—is 72 points, or 1 inch. No single letter is the full height of its point size.

Take a look at Figure 4, and you'll see how all of this has its roots in the days of metal type pieces. Each letter was cast in relief on a metal rectangle (backward, of course), and the rectangles were placed side by side, then aligned along the bottom in a "tray." Though equipment has

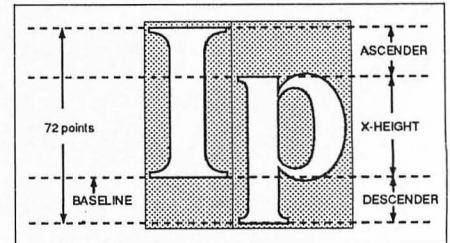

Figure 4. — Measuring type.

point sizes used more selectively. You may want 5- to 7-point type for superscripts and subscripts; point sizes of 14 and higher are good for headlines, section headings, titles, etc.

**Printers and printing.**

All these fonts and attributes will be about as useful as an ST without a disk drive, if you don't have something with which to produce a tangible end product. In desktop publishing, what you need is hard copy, which requires a printer. And not just any printer. After all, every printer has its limitations (some more than others, admittedly), and not every feature you want to print will come out as you planned.

First and foremost, a letter-quality printer using a daisy wheel or such will certainly *not* be capable of printing multiple fonts in varying pitches and attributes, in addition to printing graphics! For DP use, the minimum you need is a graphics-capable dot-matrix printer. A laser printer would be the best choice.

Of course, if you're preparing text for professional presentation, you'll need the best possible results, which almost necessitates a laser printer. If you're not presenting a report to the board of directors, then a dot-matrix or ink-jet printer will do. The average dot-matrix printer in home use has nine pins with which to print. This limits the smoothness and detail you can print. The 24-pin dot-matrix printers produce far superior documents. Laser printers, with a resolution of some 300 dots per inch, blow both out of the water. Figure 5 is presented to give you an example of the difference in printer output.

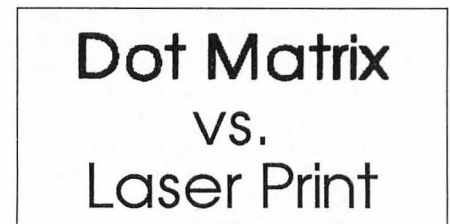

Figure 5. — Comparative output.

Notice how much better the laser printer's type is over the standard dot-matrix output. The difference is significant, but that doesn't mean the dot-matrix version is horrible. It's perfectly legible, and, as long as you don't make the text too small, it will work nicely for most applications.

If you feel you *must* have the high quality of a laser printer, be prepared to shell out some serious dollars. A cheap laser printer will cost about \$2000; an expensive one (say, an Apple LaserWriter) will run over \$5000! Atari has announced its own laser printer, which will reportedly sell for \$1500. Be forewarned: this hasn't hit the market (yet), and it will require your ST to have at least 2 megabytes of RAM. This is because the printer reportedly uses the computer's RAM rather than carrying its own, to keep printer cost down. Better get a memory upgrade or Mega ST to use this one.

### Columns and tombstones.

When we speak of text, we're almost always talking about columns. Even if each page has only one block of text, that text

is, technically, a column. If you're laying out pages for a magazine or newsletter, you'll almost always have at least two (and, maybe, three) columns of text.

If you're formatting small pages—say, less than 8½x11 inches—you probably won't want to use multiple columns, because the columns would have to be so narrow you could only fit a few words in each line. This will cause problems: one good-sized word may spill over the width of the column, be shifted down to the next line, and then you'll find the program padding the short line with so much blank space it will look awful. And, if you turn off justification (left blocking the text), you'll get ragged columns that look terrible. Further, you always have to be aware of what point size you're using—what might seem a commodious column will quickly become a cramped clutter if you use a text size that's too big for it.

Further, while smaller point sizes mean less white space padding, they can sometimes be too small. After all, 6-point text is not easy reading. In fact, a lot of people have trouble reading compressed type

(about 17.5 cpi), and that's normal height, albeit narrower. This is the reason most publications and books use point sizes in the 8- to 12-point range. Such sizes fit a good deal of material on each page, while remaining readable.

Double-column layout is probably the most "handsome" for magazine or newsletter pages. Triple columns tend to look a bit crowded. While fine for straight copy like reviews and tutorials, they're really not suitable for your hard-to-read material. Technical text should be presented in single or double columns only, unless you're printing on oversize paper (wider than 8½ inches). For examples, look no farther than the magazine in your hands. Leaf through the pages and see how various articles are formatted, how many columns are used for various types of subjects. Then look at other magazines and see how they format their pages. Do you like the way these magazines appear? Are they just fine? Too cluttered? Too empty looking? See what appeals to you, and—this is important—why it appeals to you.

In order to use any tool or technique,

<p><b>Introspection</b></p> <p>It has come to my attention that the subject of computer piracy is rampant in the Atari community. I always hear denials, and yet the accusations stand. The question is: "Is the piracy problem worse with Atari users than with users of other systems?"</p> <p>My answer is two fold. First, there seems to be more true "hackers", percentage wise, using Atari systems than with other computers, so it's not unreasonable to expect them to have the knowledge to crack the protection on some software. But then, cracking protection is a business, so we can't blame hackers.</p> <p>I feel that there isn't any worse of a problem with Atari users as opposed to users of other machines, but that since there are fewer Atari computers, the impact of the same percentage of piracy is much higher.</p> <p>This will no doubt stir up debate. Any rebuttals?</p>	<p><b>COMMIES FROM SPACE</b> A REVIEW</p> <p>Space games are in no way an endangered species, as yet another release from that overproductive company, StarKludge Software sorely demonstrates. The box art seems to promise you the most fantastic graphics you've ever seen, but once you get down to the real screen it's just another variation on Space Invaders.</p> <p>Alien Reds, led by a clone of Warren Beatty, are advancing on Earth. You, armed with a single shot cannon (can't somebody please improve the loading mechanism?), must fend off wave after wave, in rather mechanical an uninspired fashion. Move left, zap, move right, zap. In fact, the game's graphics get interesting in only two situations: when an alien lands and turns the white house into a clone of the Kremlin, and in the Bonus Round, where you must shoot down The Warren Beatty Clone's books on method acting raining on you.</p> <p>All in all, Commies from Space is misleading, and once past its "Red Herrings" disappointment awaits.</p>	<p><b>My Opinion</b> by Atilla the Nun</p> <p>It seems to me that people, particularly personal computer users, are becoming more and more nosy with regard to other people's business. Some hackers like to break into the computers of major corporations, or hospitals, examine records, and tailor them in any way that pleases them. Less sinister, though hardly more condonable, is the habit many users have acquired of reading anything and everything they can get their grubby little paws on so they will know more than their fellow hackers. This certainly requires a sick mind. After all, ignorance is bliss, and bliss is something the world needs more of today. I say a little ignorance goes a long way, and we should be closing the minds of these digital delinquents before they go too far.</p> <p>Admit it, reader, you are one of them. If not, why would you go through all the trouble to try to read this microscopic print in mock pages in an article on Desktop Publishing?</p> <p>Repent!</p>
<p><b>For Sale:</b></p> <p>--Ameoba personal computer system. Features Kickstand O.S., disk breaks, and the famous Ameoba interrupt driven multi-crashing capability. Only \$2,995.95! Call 555-9876 and make offer!</p> <p>--Atari 1090XL expansion boxes, for use with your 1450XL! Limited quantities in stock. Call your local Vapor Ware Ltd. dealer for more information.</p> <p>--In stock now! As reviewed by Arthur Leyenberger in ANALOG: Magical Software's <i>Planet Missionary</i>, and General Giant's <i>Simple Calc</i> and <i>Mall Game</i>, as well as rare copies of the script for the planned Atari Orson Welles commercials! Call Vapor-Heaven at 555-6789 now.</p>	<p><b>Ameoba Secrets... Revealed!</b></p> <p>A disgruntled former employee of Kludges R Us recently spilled the beans on the secrets of the capabilities of Kludge's famed Ameoba computer. According to our nameless source (George Jackson, 32A, Milton Ave., Hanslow, Middlesex), the Ameoba's graphics &amp; sound power resides in three custom chips: <i>Larry</i>, <i>Moe</i> and <i>Curly</i>. <i>Larry</i> plays the sound, <i>Moe</i> manages the other two, and <i>Curly</i> slaps graphics on the screen and slaps itself. As to the famous "interrupt driven multi-crashing capabilities" that is the job of the secret <i>Walk &amp; Chew Gum</i> processor, which can't do both, or anything else, at the same time. Atari's reaction to all this was "Get off the phone!"</p>	<p><b>Tired of Bugs?</b></p> <p>Are'n't we all? Well, recent studies have concluded that many of the system failures we've blamed on bad code or user error are actually caused by small insects and arachnids, which seem to have eluded an affinity to digital circuits!</p> <p>Studies at Blatidae Elegans U confirmed this long held theory. Researchers are now working on a silicon safe insecticide to combat the problem.</p>

Figure 6A.

<p><b>Introspection</b></p> <p>It has come to my attention that the subject of computer piracy is rampant in the Atari community. I always hear denials, and yet the accusations stand. The question is: "Is the piracy problem worse with Atari users than with users of other systems?"</p> <p>My answer is two fold. First, there seems to be more true "hackers", percentage wise, using Atari systems than with other computers, so it's not unreasonable to expect them to have the knowledge to crack the protection on some software. But then, cracking protection is a business, so we can't blame hackers.</p> <p>I feel that there isn't any worse of a problem with Atari users as opposed to users of other machines, but that since there are fewer Atari computers, the impact of the same percentage of piracy is much higher.</p> <p>This will no doubt stir up debate. Any rebuttals?</p>	<p><b>Ameoba Secrets... Revealed!</b></p> <p>A disgruntled former employee of Kludges R Us recently spilled the beans on the secrets of the capabilities of Kludge's famed Ameoba computer. According to our nameless source (George Jackson, 32A, Milton Ave., Hanslow, Middlesex), the Ameoba's graphics &amp; sound power resides in three custom chips: <i>Larry</i>, <i>Moe</i> and <i>Curly</i>. <i>Larry</i> plays the sound, <i>Moe</i> manages the other two, and <i>Curly</i> slaps graphics on the screen and slaps itself. As to the famous "interrupt driven multi-crashing capabilities" that is the job of the secret <i>Walk &amp; Chew Gum</i> processor, which can't do both, or anything else, at the same time. Atari's reaction to all this was "Get off the phone!"</p>
<p><b>COMMIES FROM SPACE</b> A REVIEW</p> <p>Space games are in no way an endangered species, as yet another release from that overproductive company, StarKludge Software sorely demonstrates. The box art seems to promise you the most fantastic graphics you've ever seen, but once you get down to the real screen it's just another variation on Space Invaders.</p> <p>Alien Reds, led by a clone of Warren Beatty, are advancing on Earth. You, armed with a single shot cannon (can't somebody please improve the loading mechanism?), must fend off wave after wave, in rather mechanical an uninspired fashion. Move left, zap, move right, zap. In fact, the game's graphics get interesting in only two situations: when an alien lands and turns the white house into a clone of the Kremlin, and in the Bonus Round, where you must shoot down The Warren Beatty Clone's books on method acting raining on you.</p> <p>All in all, Commies from Space is misleading, and once past its "Red Herrings" disappointment awaits.</p>	<p><b>For Sale:</b></p> <p>--Ameoba personal computer system. Features Kickstand O.S., disk breaks, and the famous Ameoba interrupt driven multi-crashing capability. Only \$2,995.95! Call 555-9876 and make offer!</p> <p>--Atari 1090XL expansion boxes, for use with your 1450XL! Limited quantities in stock. Call your local Vapor Ware Ltd. dealer for more information.</p> <p>--In stock now! As reviewed by Arthur Leyenberger in ANALOG: Magical Software's <i>Planet Missionary</i>, and General Giant's <i>Simple Calc</i> and <i>Mall Game</i>, as well as rare copies of the script for the planned Atari Orson Welles commercials! Call Vapor-Heaven at 555-6789 now.</p>
<p><b>Tired of Bugs?</b></p> <p>Are'n't we all? Well, recent studies have concluded that many of the system failures we've blamed on bad code or user error are actually caused by small insects and arachnids, which seem to have eluded an affinity to digital circuits!</p> <p>Studies at Blatidae Elegans U confirmed this long held theory. Researchers are now working on a silicon safe insecticide to combat the problem.</p>	<p><b>My Opinion</b> by Atilla the Nun</p> <p>It seems to me that people, particularly personal computer users, are becoming more and more nosy with regard to other people's business. Some hackers like to break into the computers of major corporations or hospitals, examine records, and tailor them in any way that pleases them. Less sinister, though hardly more condonable, is the habit many users have acquired of reading anything and everything they can get their grubby little paws on so they will know more than their fellow hackers. This certainly requires a sick mind. After all, ignorance is bliss, and bliss is something the world needs more of today. I say a little ignorance goes a long way, and we should be closing the minds of these digital delinquents before they go too far.</p> <p>Admit it, reader, you are one of them. If not, why would you go through all the trouble to try to read this microscopic print in mock pages in an article on Desktop Publishing?</p> <p>Repent!</p>

Figure 6B.

Figure 6. — Tombstoning.

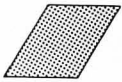

in almost any field, you must understand why you react in certain ways to its use. Then, you must gauge whether your own work will elicit the same or a different reaction if you use the same technique. For example, if you've just seen a movie you didn't like, try to understand *what* you didn't like. That way, you'll know what not to do when you make that kind of movie. Get the idea?

If your reason for liking something is that it looks neat, imagine one of the items you intend to print formatted in a similar manner. Does it look all right to you? Or is the format you're looking at well suited to the subject matter and style of that magazine, but inappropriate for your document? Such critical thinking is one of the cornerstones of artistic expression, allowing you to formulate an idea, analyze it, locate weak or bad points, then reformulate a (we hope) better idea.

Looking at the many users group news-

letters that have crossed my desk these past two years, I can see some of the no-nos I learned of in journalism class. The most common and annoying one specifically related to text columns is *tombstoning*. See Figure 6A on the previous page.

Note how each column, each division of columns, is lined up evenly with the others, like "a row of tombstones in the cemetery," as my journalism teacher used to say.

This pitfall, though it doesn't make a page unreadable, certainly makes the page look flat and boring. You want your copy to look interesting, so you'll want to avoid tombstoning at all costs. Figure 6B illustrates the same page with its columns rearranged and resized. Looks much better, doesn't it? Varying column length and width, and the arrangement of headings and "cuts" (picture elements in text) help break up the page, making it more interesting to look at.

## Side order.

Sidebar often accompany articles or documents that cover complex or broad subjects. Careful placement of these can help break up what would otherwise be page after page of flat-looking text.

Let's say you're working on your users group newsletter, and you have an article discussing the last Atari Expo. You also have a short article about plans for the next scheduled Expo. You could print it elsewhere in the publication, but, since the smaller article is on a topic related to the main one, it would be a good idea to put them together. The best way to integrate the duo, without actually merging the two articles (which would surely annoy the authors), is to make the shorter one a sidebar in the main one.

So, on the second or third page of the main article, you reserve one column and put the short article there, physically separating it from the main article with

back left corner of the keyboard, which is where port 1 (joystick) is also located. The mouse port (0) is in a notch under the center of the back of the keyboard. There is a narrow "channel" for the mouse cord to follow, leading out the right side of the keyboard. If you are left handed, you simply ignore the channel, feed the cable out the back of the notch, and it will easily go around the left side of the unit. These ports are much easier to get at than those on the 1040ST! The keyboard also has two flip out panels on its bottom, which are used to tilt the keyboard towards you. When closed, the keyboard lays quite flat.

As to the keys themselves, they don't look any different, but they definitely are much tighter. It's not nearly so easy to trigger a key by brushing it. Even the function keys don't feel "mushy".

**THE NEW TOS/GEM**

Perhaps "improved" is a better word. The Desktop looks just like always. Same old stupid icons. The menus are the same, with the exception of the Options menu, where at the very bottom is an option called "Blitter"! If a check mark appears next to it, the blitter chip is ON, if not, it's inactive (more on this later). The Print Screen and Save Desktop functions now present Alert Boxes confirming if you wish to proceed or cancel. You can't set a drive for saving the Desktop to, but at least this will prevent you from accidentally overwriting your current DESKTOP.INF file (which I seem to do about half the time I aim for "Set Preferences").

The first thing I tried was typing an underline in the time/date area of the Control Panel, and, much to my relief, I wasn't greeted by the three bombs which usually accompany this action with the old TOS. In fact, my best efforts proved insufficient to crash this machine. No file or I/O error I created caused a bomb. Hopefully this is a good sign.

Neil Harris stated that the text handling routines had been overhauled, and even sans blitter, the text in windows seemed a

*Continued...*

**DO YOU NEED A MEGA?**

Of course, many of you are rolling your eyes at the prospect of another ST. You just got a 520 or 1040, and now you wonder if Atari isn't trying to get you to buy a new computer every year! Of course, we all know Atari would be tickled if we bought a new ST yearly, but that's impractical. The question remains as to just what the Mega ST units have to offer, and if it's an offer you can't or shouldn't refuse.

The first thing the Megs offer is more RAM. 2 & 4 megabytes respectively. If you need more RAM, though, you can purchase it for your current unit. I've seen 2 and 4 megabyte 520s and 1040s, so RAM really isn't enough of a reason to trade up.

The second thing they offer is the blitter chip and the new TOS. The blitter will no doubt be put to use by software developers, and I imagine soon you'll see ST products with the label "blitter chip required" on the box. Further, the revised TOS fixes a number of bugs in previous releases, and seems less prone to bomb. Both are worth having, although a few programs may not run at first because of some programming trick that the new TOS doesn't allow. Atari has stated that the new TOS ROMs and blitter will be made available as "upgrades" for current ST owners, though no one has really stated just how the blitter will be inserted into a computer without a socket. Putting one in may be more trouble than it's worth.

Finally, if you want the potential for extensive system expansion, the Mega allows access to the full processor bus, which the 520 and 1040 don't. Theoretically, the Megs will be able to easily take on memory upgrades, peripheral boards, etc., with no need for extensive internal tinkering.

Finally, the Megs have an improved and detachable keyboard better suited for touch typing, which you might prefer.

You must weigh all these factors and decide if a Mega is in your future. If you have doubts, *don't* buy! They'll still be there six months later if you find you can't live without one!

**Figure 7.**  
**Sidebar.**

a scroll bar will result in a auto-repeat scroll. No more multiple clicks to scroll through a window. 1st Word benefitted from this, and when the blitter was engaged, seemed faster at going from end to end in a large file.

**The Blitter!!!**

I have been *dying* to try this out for ages! Anyway, it's present in the Mega, and, by golly, it *does* work! On the Desktop, it seems to speed up window fills and screen redraws, though it's hard to tell. The "pop" of appearing and disappearing windows is the same, though I imagine that's because the routines are timed to one of the system clocks.

---

...the best example of the blitter at work was the *NEO-Bird* demo. Imagine it going 4 to 5 times normal speed and you can imagine what the blitter can do.

---

Many users have voiced worries that the blitter would cause some of their programs to go crazy with speed. I found this shouldn't be much of a problem. I tested StarGlider, Star Raiders, Crystal Castles and Battlezone, and all ran as always. Apparently, they too monitor system clocks, and are unaffected by the blitter. Maybe you're disappointed by not getting to play Star Raiders at Warp 45, but it keeps the games playable.

However, the best example of the blitter at work was when the good old *NEO-Bird* demo was run. If you have it, run it, and notice how fast the cockatoo goes. Now, imagine him going between 4 and 5 times that speed and you can imagine what the blitter can do. Why, that chip could potentially make even the Aegis Animator ST's jerky cel animation halfway

**Figure 8.**  
**Blocks of text.**

presentable!!! Shiny Bubbles and FujiBoink! showed no difference in speed.

The system default is for the blitter to be "on", although Neil Harris told me that if a DESKTOP.INF file were present on my boot disk, the blitter would be disengaged. I imagine that Save Desktop now saves the status of the blitter as well, which could be indicated with a single bit for on or off.

### A Few Failures

While Charles F. Johnson's "Font-Trix" worked, an early version of another accessory of his (coming to ST-Log soon!) didn't. The machine got as far as drawing the menu bar and seized up. No idea why. Also, Beta versions of Broderbund's Art Director and Film Director wouldn't run. The error I got was something like "Not enough memory to run this application. Use TOS in ROM or remove all Desk Accessories before retrying." This on a 4-megabyte ST! I have a feeling this has something to do with memory addressing, and the error is generated when a free RAM check reveals a number out of the specified range. In this case, it could be that the some 3,850,000 bytes of free RAM was so big that the programs didn't realize what it really meant!

Programs I tried that DID work, apparently without a hitch, were: CAD-3D 2.0, Star Glider, Crystal Castles, Star Raiders, DEGAS Elite, 1st Word, NEO-Chrome, Battlezone, SLIDE.NEO (NEO-Bird), Shiny Bubbles, Fuji-Boink and Flash.

### Until Next Time...

Neil Harris said the plan is to ship the Mega ST2 and 4 units in bulk in August. The Mega ST1 has been shelved, sparing the 1040ST from an early grave. As to blitter and TOS upgrades for the current ST models, I have no inside knowledge.

Hopefully, another "close encounter" will be soon following, and when it does, all of you will be the first to know. Now, if you'll excuse me, it's late, and I'm going to bed... visions of blitter chips dancing in my head!

# The GEM programmer's package of the year!

- Prospero Pascal or Fortran compiler
- GEM-based 4-window editor
- Programmer's workbench
- Linker
- Librarian
- Run-time library
- Complete set of 190 GEM bindings for Prospero Pascal or Fortran
- Symbolic debugger
- Cross referencer
- Syntax checker
- 250 pages of language documentation
- 250 pages of GEM VDI documentation
- 250 pages of GEM AES documentation

Need we say more?

Pascal: \$149 Fortran: \$199

Prospero Pascal for GEM and Prospero Fortran for GEM for Atari ST will be available from October 1987. Call 011-441-741 8531 for a free info pack or to order (Visa, MC, Amex). Upgrade available for existing users. Our mailing address is Prospero Software Ltd, 190 Castelnau, London SW13 9DH, England. Fax 011-441-748 9344. Telex 8814396. GEM is a trademark of Digital Research.

## Prospero Software

LANGUAGES FOR MICROCOMPUTER PROFESSIONALS  
190 CASTELNAU, LONDON SW13 9DH, ENGLAND TEL 01-741 8531 TELEX 8814396  
CIRCLE #130 ON READER SERVICE CARD

## ATARI USERS' GROUPS

Bakersfield Atari Computer Enthusiasts (BACE)  
P.O. Box 40203, Bakersfield, CA 93384  
Meetings; BBS; newsletter. President: Bob Brown.

South County Atari Users Group (SCAUG)  
c/o Dave Sillas, 501 Sieber Ct., San Jose, CA 95111  
Meetings; newsletter.

Santa Barbara Atari Computer Enthusiasts (SBACE)  
P.O. Box 3678, Santa Barbara, CA 93130  
Meetings; BBS; newsletter. President: Conrad Weiler.

Atari Federation  
P.O. Box 5367, Vandenberg AFB, CA 93437  
Meetings; BBS; newsletter. President: Shirl A. Dellinger  
(805) 734-2451 (voice) or (805) 734-1407 (BBS)

Front Range Atari Users' Group (FRAUG)  
c/o Gerald Belfor, 3012 Rockborough Ct.,  
Fort Collins, CO 80525  
Meetings; newsletter.

Blackhawk Atari Computer Enthusiasts (BACE)  
220 Sherman Ave., Waterloo, IA 50703  
Meetings; newsletter. President: Allan Freeman.

Suburban Chicago Atarians (SCAT)  
P.O. Box 72266, Roselle, IL 60172  
Meetings; BBS; newsletter. President: Jeff Williams.

Atari Computer Owners Resource Network (ACORN)  
c/o Ken Helms, 3627 Iowa Ct., Fort Wayne IN 46815  
Meetings; newsletter. President: Kim Stahn.

Lawrence Atari Computer Club (LACC)  
P.O. Box 1415, Lawrence, KS 66044  
Meetings; BBS; newsletter. President: Mark Duncan.

Greater Kalamazoo Atari Users Group (GKAUG)  
607 Lay Blvd., Kalamazoo, MI 49001  
Meetings; BBS; newsletter. President: Daniel Young.

Manitoba Atari Computer Club (MACC)  
718 Beresford Ave., Winnipeg, Manitoba R3L 1K1, Canada  
Meetings; BBS; newsletter. President: Rick Singbeil.

Atari Computer Users' Group of the Future  
Alejandro Lotwin T., Apartado Postal 11-456,  
06100 Mexico, D.F. Mexico  
Phone: 584-33-28, 519-71-63

### ATTENTION USERS' GROUPS

If you would like your organization to be listed here, send information (and newsletter, if appropriate) to **ST-Log** Group Listing, P.O. Box 23, Worcester, MA 01603. **ST-Log** is not responsible for errors in copy.

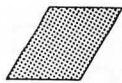

a box or lines (see Figure 7). Thus, in effect, the short piece becomes part of the main article—while both maintain autonomy. This also breaks up the main article, so it doesn't look tombstoned.

Short blocks of text can be intermixed almost anywhere. You could create a double-column block and put it at the top or bottom of a page, rather than run it straight down as one column. One of the best ways to break up a boring page is to print a quote in large type somewhere toward the center of the page, as in Figure 8. This technique, like all others, should be used sparingly; overuse makes even the best idea monotonous.

**White space.**

Nothing you should think about . . . Let me rephrase that. You should think about how much *nothing* you have in your document. Every page has some blank space, and you have to decide how much to leave: margin size, space between columns (gutters), amount of blank paper at the top and bottom of pages, etc.

It's easy to leave too much blank space, making your readers think you didn't have enough material. Too little blank space is just as bad (or worse), as your document will look cluttered. Your readers might well think they'll get eye strain just looking at it. As always, you have to find the appropriate balance. Sparing use of blank space, particularly at the beginning of an article or at subheadings, can provide a little visual "breathing room," so the text doesn't look as if it will suffocate under its own weight (so to speak).

**Graphics and text.**

Fonts and formats are all well and good, but one of the best things about DP software is that it lets you integrate text and graphics in the same document. Not only do all the programs I know of give you tools for creating graphics from inside the program, but you can usually "import" pictures created outside (such as DEGAS- or TINY-format pictures). This gives you tremendous latitude for visually interesting documents.

Figure 9 features an illustration of the back panel of a Mega ST, drawn with DEGAS Elite (high resolution) and imported into Publishing Partner. The picture was "cropped" (trimmed as needed) and scaled to fit in a particular space, and the labels for the illustration were added when the page was being formatted. The columns were resized to fit above the illustration. By providing such an illustration, you give the reader additional in-

**PROCESSED PROSE**

By Maurice Molyneux

**CLOSE ENCOUNTER WITH THE MEGA ST4**

We've ALL been waiting what seems like forever for Atari to finally get its Mega ST computers out the door. They were announced in January (seems like longer back, though), and only now does absolute proof of their existence appear to mine eyes in the form on an actual unit! Not only did I get to see one (Mega ST4) in the "flesh", but I got to sit down and play with it for quite a while. In fact, I ran something like 10 programs on it. My thanks to Neil Harris of Atari and Rod Coleman at Cimmaron Computers in Reno, Nevada, for the opportunity to play with this long sought machine. (Now, *don't* go calling Cimmaron and expect to order one, because as of this date -July 12- they don't have them yet. The one I saw was there for a special event and went back to Atari HQ several hours later.)

**THE SYSTEM UNIT**

This hasn't changed since the photos we've all seen. The main unit is a box, about 13 x 13 inches square and about 3 inches tall, with a double-sided 3.5 inch

floppy drive in the front of the machine to the right. Interestingly, all systems lights on the unit I saw were *green*. No red LEDs. The right side of the unit is blank, though the left side has an opening which reveals the connector for the keyboard cable just forward of the cartridge slot. Around the back of the unit are all the usual ports, and one interesting hatch, arranged as follows :

The interesting hatch is, as we've all been hoping for, an open line to a connector which gives access to the FULL 68000 bus, thus permitting simple memory expansion, and even the possibility for carrying the bus *outside* the ST to where things like card slot equipped expansion boxes, multifunction peripheral boards, etc., can be added. Next to it is a small nameplate with the Atari logo, which one magazine claimed was where a second DMA port could be added. I do not know if this is true.

Finally, the Mega has a very quiet internal fan and a built-in battery backed up clock. I'd forgotten about the clock, but when one of my disks auto-ran a program to read the clock, I was suprised to see that it worked!

**THE KEYBOARD**

This is nearly the size of a 520ST, though slimmer and *much* tighter. The keyboard is connected to the system unit by a cable which connects in a notch under the

*Continued...*

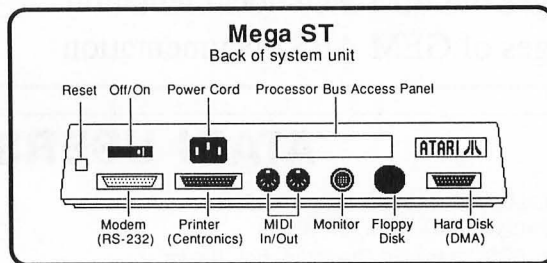

Figure 9. — Adding graphics.

formation for reference—and you keep the page visually interesting (a constant challenge).

There's not a whole lot I can say about graphics, just that you have to pay attention to many of the same things you do in text. You have to decide if the graphic will enhance or detract from your text. Will it clutter the page unnecessarily or look like something you stuck in for filler?

As to importing pictures, it's important to remember that color pictures are difficult to use. When converted to black-and-white "dithered" patterns for printing, they can look strange. (Really, how many of us have four-color printing equipment?) If you're going to import a color picture, it's best to convert it beforehand. If nothing else, change the colors to gray scales; that will make it easier for the program to assign textures for printing. Best of all, use a program to convert the picture to monochrome *before* you import it. PIC

SWITCH 0.7 (it's Share-ware) does an excellent job converting color to monochrome. By the way, you don't need a monochrome monitor (with Publishing Partner) to import and use monochrome pictures in your documents.

**Page eject.**

What all this comes down to, really, is developing an eye for which techniques work or do not work in combination, and in which situations they are suitable or not. It's not something someone can teach you, but something you have to learn.

The trick is to keep the following constantly in mind: clarity, readability, logical progression (you don't want the end of an article continued on a page preceding the beginning of the piece), and overall look. Of course, it's also nice if the text you're going to print is well written and interesting. . . but that's another article. //



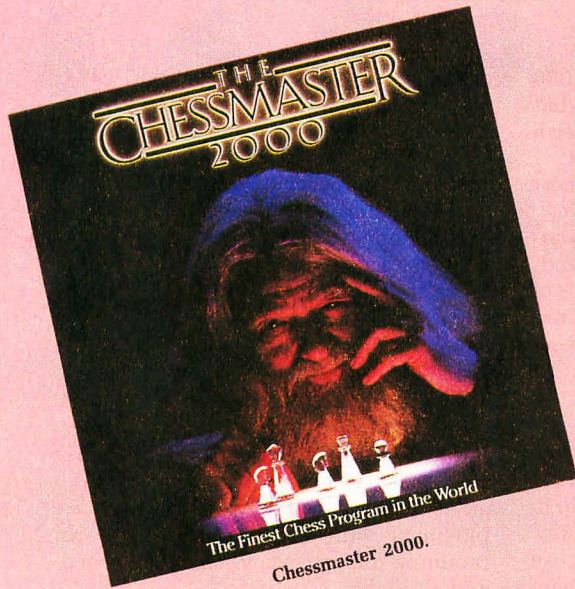

# Thinking man's gaming.

## ST programs to test your wits.

by Bill Kunkel, Arnie Katz  
and Joyce Worley

Skill and luck are the basic building blocks of all games. The percentage of each ingredient determines the flavor of the contest. Sometimes the emphasis is on chance, as in card games; even in the world of pasteboards, thinking can provide one contestant with an edge.

An example is in the "card-counting" strategy used by some Blackjack players. Unlike ordinary 21 players, who bid or stay based exclusively on the cards they hold (as well as on essentially meaningless conditions, like how lucky they feel), card-counters keep mental track of what's already been played. This minimizes the chance factor, and puts the weight on skill and knowledge. The efficacy of this approach is testified to by the fact that long-time card-counters like Ken Huston (also famous for authoring several volumes on video game strategy) are *persona non grata* at gaming tables from Las Vegas to Baden-Baden.

The thinking gamer always strives to emphasize skill over chance. Chance or luck is arbitrary, undependable and, as the Temples of Mammon in Vegas and Atlantic City prove, is ultimately geared *against* any individual player. Luck is fine for the dilettante who visits the gaming halls, race tracks or card tables as an occasional diversion. However, the professional horserace handicapper, who plays day

after day, must supplement his good luck charms and totems with a solid underpinning of horse sense and behind-the-scenes information.

Games like chess emphasize strategy to the exclusion of chance. Chance is intrinsic to any game's basic dynamics (different opponents play games differently), but chess eliminates variables within itself. Chess is a symbolic representation of war, but, unlike the real thing—where random elements such as weather play pivotal roles—chess is war fought under laboratory conditions. The conflict is waged between symmetrical armies on a Rorschach battleground where the wind doesn't blow, the tides do not change and the horses never get sick.

Bridge requires more skill and involves less chance than any other card game. **Bridge 5.0**, designed by Art Walsh and published by Artworx, is perfect for sharpening bidding and trick-taking skills when you don't have three potential participants at hand. It lets the solitary computer user compete against a computer-controlled team with a robot partner.

The program, which runs in medium resolution or monochrome, includes the Standard American Bidding System and recognizes the popular Blackwood and Stayman conventions. The computer will make a bid for you with a click of the mouse, if desired.

Although it's possible to type in bids, the mouse-activated command control system is quick and easy to use. The same

point and click methodology works nicely for the actual play of the hand.

Bridge 5.0 has many handy features. The most important allows the user to enter a hand for each player, and then save those hands to disk. This makes it possible to conduct a solitaire "duplicate" tournament with this program. This arrangement removes the single biggest chance element—the randomness of the deal. When several participants play the same cards, it's easy to see who is, in fact, the most skillful.

The graphics are serviceable rather than stunning. The cards are easy to see and manipulate, but Walsh has done little to make Bridge 5.0 visually exciting. As it probably should be, the spotlight is on the strategy.

Anyone who knows the rudiments of bridge can enjoy this program, but it's no "learn to play" disk. Novices should forego Bridge 5.0 and try the same company's **CompuBridge**, which is a computerized tutorial. For those who know their trumps, however, Bridge 5.0 deals a grand slam of entertainment.

The best news chess mavens have had in years is that **Chessmaster 2000** from Software Toolworks has arrived on the ST. The state of the art home chess program, CM 2000 provides everything but actual tactile contact with the intricate pieces.

CM 2000 plays a fine game of chess, but its designers were clearly looking for more than just another "it beat Sargon!" chess wizard. The vast majority of users will

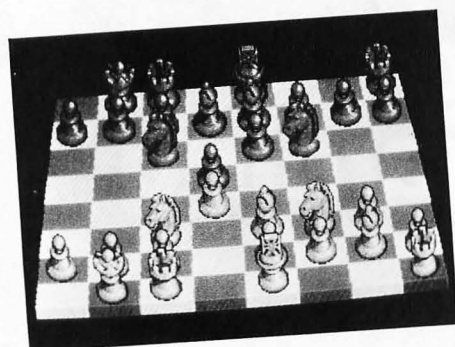

Chessmaster 2000.

never come close to maxxing out even the simplest chess program; they are more concerned with how the game looks and plays (speed, extras, movement system; i.e., the play environment). This program addresses those aspects brilliantly. Pull-down menus let the user change pieces (metal or wood) and board colors, or alter the perspective from which they view the game (two-thirds or overhead). The board can be rotated a full 360 degrees, and the program uses excellent digitized speech to regularly communicate with the human player.

The mouse manipulates the on-screen cursor, which, in this case, is a tiny hand with which players "pick up" and move pieces. Above the visual display, the move number is noted, and each move is timed to the second.

The program also offers an impressive range of extras: moves can be displayed exclusively in chess notation; printouts are available at any point; and players can set up special positions or solve mate.

Chessmaster 2000 also features all the usual "File" options (saving a game, loading a previously saved game, etc.), and plays a brisk game. The only possible complaint would be the inability of the user to fine-tune the difficulty level of the computer player. The program offers a "newcomer" mode for beginners, and the style of the computer opponent can be dictated to a certain extent. In "best" style, the computer always makes its optimal move. In "normal" mode, it generally makes the optimal move, and "coffee-house" play means a mix of random and optimal moves.

The problem is obvious: how does one make the computer play stupidly without degrading the entire process? Of course, even when the computer makes a so-called "random" move, it isn't *really* just pulling a move out of its silicon hat; the system simply expands its parameters slightly.

In short, even at entry level, CM 2000 plays a rugged game. One can't help but feel that the novice user might prefer a wider range of selectable skill levels.

But then, war is hell—even in its most rarified form.

Strategy fanatics who prefer their warfare a little less abstract and ritualized, can appease their appetites with a pair of new releases for the ST: **Colonial Conquest** and **Roadwar 2000** from SSI (where "strategic" isn't their middle name, it's their *first* name).

Colonial Conquest is a game in the grand tradition of Diplomacy, the board game Risk, and Electronic Arts' Lords of Conquest (not available on the ST). Up to six major countries (England, Germany, France, the U.S., Japan and Russia) use the twin tools of diplomacy and warfare in a battle for control over more than 120 minor countries, with three scenarios covering the years 1880-1914. Conquests, both on the battlefield and behind the scenes, are rewarded with "victory points."

The six empire-building nations are controlled by human players, the computer, or are neutral. Human players can negotiate, à la Diplomacy, and establish informal agreements (adding the delightful element of treachery, and a large dollop of that ol' debbil "chance").

The game breaks down into three annual phases: Build (army and/or navy fortification, economic aid, espionage and subversion); Movement (army/navy); and Combat.

The screen display consists of a map four screens wide and two screens high, with major and minor countries, status squares (the primary area within a country), regions (the world is divided into eight), and bodies of water (for access by the navy), all graphically delineated.

Colonial Conquest is an excellent adaptation of a classic strategy gaming theme. This type of game requires not only an ability to strategize, but a high degree of interpersonal and communication skills. Colonial Conquest challenges the player to be diplomat *and* supreme military commander, a blend of abilities rarely tested in tandem.

Roadwar 2000, on the other hand, assigns you a more clear-cut role: four-wheel warlord in a post-armageddon nightmare. Cities still exist in this wasted land, but from the player's perspective, they're fit only for plundering.

The player moves his army along the highways of a nuked-out America through the visual expedient of an icon-based

overhead map. At each location, using mouse and pull-down menus, the human commander can scout the area, loot it, and/or send a search party in after new vehicles and recruits. An army can travel on its stomach, but an auto cavalry's belly requires more than just people food; it wants regular infusions of gasoline and spare tires, as well.

Periodically, the player's force will encounter rival road warriors, precipitating a showdown (which Roadwar presents in Abstract, Tactical and Quick action). At the point of encounter, a prompt inquires if the user prefers "detailed" combat. Abstract combat is fast and furious, whereas detailed battle allows for precise deployment with such lovely options as ramming, maneuvering, changing speed and firefights.

Board games comprise an interesting mix of skill and chance. Traditionally, players flip a spinner or roll dice (the classic methods of producing a random number) to determine movement options, then rely on their skill once they arrive at a milestone or destination. Straightforward board game translations rarely turn up in electronic form. Hence, Intellecreations' **221B Baker St.** is all the more welcome to the ST.

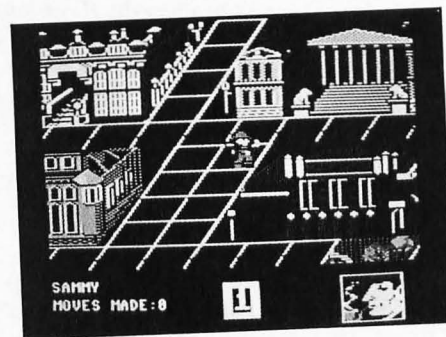

221B Baker St.

Based on an original board game by (no kidding) Jay Moriarty, and brought to the ST courtesy of Steven Duboff, Jeff Harth, John P. Sohl and Russ Wolvek, 221B is an attractive, highly playable, mystery-solving contest, in which pieces representing characters from Conan Doyle's Sherlock Holmes cannon (Holmes, Watson, Irene Adler and Inspector Lestrade) are moved around a scrolling on-screen "board" seen from a two-thirds perspective. Players move their surrogates after "rolling" a random number from one to six (a number generator keys through the space bar) and race to visit any of fourteen locations (apothecary, bank, docks, hotel, etc.), each of which contains a clue. The user

predetermines whether or not the clue will be coded (depending upon his fondness for word scrambling).

The package includes documentation, a casebook (absolutely necessary to solving cases), and a pad of solution check-list sheets (helpful, though not critical). Thirty cases are included with the basic disk, and Intellicreations promises supplemental cases down the line.

Board games are so unusual on com-

puters that 221B Baker St. may seem like a diversion from the Stone Age for some computer gamers, but partisans of this type of contest should be delighted. The only thing obviously missing from this translation is a computer-controlled player (or players, using simple AI programs) to contest with the solitary user. The game can be played solo, but not against a computer player. The random number generator becomes a moot element here, since

the player isn't racing against other pieces. The game is concerned exclusively with decoding and solving the mystery.

In any case, the brain's the thing here, and deductive reasoning is the skill of the day. Games like these are all thinking persons' delights. So put on those cogitation caps, get ready to scratch your head, and check out the latest in high-tech strategy games. //

## Star Fleet I

**ELECTRONIC ARTS**  
1820 Gateway Drive  
San Mateo, CA 94404  
(415) 571-7171  
All resolutions \$55.00

by Andy Eddy

In the mid-70s, college students across the country were immersing themselves in the fantasy world of "Star Trek," as the television program got its second wind in syndication. Meanwhile, many others were playing a mainframe-based strategy game of the same name that required the player to navigate the *Enterprise* in outer space, destroying Klingons while maintaining the ship's welfare in the name of Federation.

In the earliest editions of the game, players were forced to print out each screen to track their ship's location and status, followed shortly thereafter by a slow video display. It's easy to see that, with its plodding pace and high popularity, the game had computer rooms clogged with students waiting their turn.

Later, as personal computers became the vogue, public domain versions of this contest were available for virtually every brand of computer (an ST version recently turned up on the ANALOG Publishing Atari SIG on Delphi). Each program tried to beat the last in "user friendliness" and excitement, but there was only so much you could do to improve it.

Now a game has been released that recreates the original and adds new features to surpass it—namely, a pinch of arcade action. **Star Fleet I**, created by Cygnus/Interstel Software, is being licensed and marketed by Electronic Arts, which is displaying a newfound commitment to ST users. Due to obvious copyright legalities, all references to "Star Trek" are squelched, but with no loss to the gameplay.

**Star Fleet I** is quite flexible: you can play a long, medium or short version; select the difficulty level of competition you face; and pick from thirty-six different spacecraft (though damage accumulated in higher levels will put certain ships out of commission for a bit).

To start, you are placed in one quadrant of a 10×10 grid. Each quadrant is respectively broken down into a 10×10 grid of sectors. At any time, you can call up a long-range scan of the eight quadrants that surround yours, or fire a probe (of which you have three) to get a readout of what objects are in each quadrant. The information you receive tells you the location of enemy ships, starbases and stars. The latter serve no purpose, other than to get in your way.

The opposition comes in two forms: Krellans and Zaldrans, who take the place of the original Klingons. To make things more difficult, the Zaldrans are mostly invisible to you and won't show up on your charts. As the game progresses and your captain's talents increase, you'll find that the skill of your opponents is increasing, as well. Nobody said this would be easy.

In addition to the above-listed evils, time is also an enemy. To begin your mission, you're given a certain number of alien ships to destroy and a time period in which to do so. During this time, you must blow away the enemy with phasers (which will drain your energy reserves), mines and torpedoes. You also have to prevent saboteurs from creeping aboard and wrecking your ship. This is done by occasionally dispatching security forces to sections of your craft.

The program recognizes your achievements through all this by keeping records of your successes and failures. Much like a bulletin board, you have to log in at the start, giving your last name and a reference to a word in the main manual—a deterrent to piracy, as the game's not copy-protected—before you're allowed to enter combat. Multiple users can have their records kept on the main disk, inspiring competition.

Rivalry comes in the form of promotions. Each successive level requires that a certain number of battles be completed with a predetermined mission rating (given as a percentage). This rating is calculated from the time it takes you to destroy the required number of ships, as well as any captured prisoners and enemy ships you deliver to a starbase, starbases rescued, etc.

The original contest is enhanced with the addition of transporters (used to send a crew of marines to the other ship for battle and the acquisition of prisoners), tractor beams (for towing ships) and elaborate shield control, among other subtleties. All of these factors are fully controllable by the player/captain.

**Star Fleet I** also has mouse or keyboard control (through the use of number and function keys). While mouse handling requires that some numbers be plugged in from the keyboard occasionally, it's recommended over full keyboard input, which is quite unreliable and inaccurate if you don't keep a careful eye on things. This is about the only black mark on an otherwise clean product.

Other positive additions are graphic

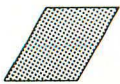

## Donald Duck's Playground

SIERRA ON-LINE, INC.  
by Al Lowe and Mark Crowe  
Coarsegold, CA 93614  
(209) 683-6858  
Low resolution \$24.95

by Joyce Worley

Huey, Dewey and Louie love to play in Duckburg's city park, but there's never enough playground equipment to keep the young quackers busy. They've complained to Uncle Donald, and it's up to him (with a little help from junior gamers) to raise the cash to outfit the park with teeters, slides and all the action toys that kids—and ducks—like best.



Learning is fun in Donald Duck's Playground.

representations of your ship's shield status, on-screen tracking of torpedoes and displays of exploding spaceships, as well as tons of bells, whistles and siren sound effects to add an arcadelike flavor to a formerly dry strategy contest. It's not overdone, either.

With software like this, it's inevitable that documentation be provided to explain all the commands and features—**Star Fleet I** is no different. To jump into the battle headfirst is inadvisable; the Officer's Manual must be read carefully, even if you've played a "Star Trek" game before. This is due to all the added features and changes the developers have undertaken. While the manual is sizable (about 100 pages), it's well-written. Also included is a supplement that singles out changes pertaining to the ST version, and

a training manual that gives detailed information, examples and hints on various segments of the game.

It's good to see Electronic Arts getting behind some satisfying software for the ST. **Star Fleet I** is a quality contest that does justice to the memory of the countless "Star Trek" games I played in college. And to tell you the truth, I'm not getting any more work done now than I did back then! //

*Andy Eddy works as a cable TV technician in Connecticut, but has been interested in computers since high school. While his family's Atari 800 is four years old, he's been an avid arcade game player since Space Invaders and is a former record holder on Battlezone.*

**Donald Duck's Playground** has entertained young computer users for several years. Hailed as the finest educational game ever devised, it was originally introduced for lower memory computers. Now, this excellent child-pleaser is available in a brand new version, with flashy ST graphics that make it look even better than before. That's saying a bill-full, since this program's graphics were specifically designed to enchant kids.

Donald Duck stars in the production, along with his supporting cast of Mickey and Minnie Mouse, and Goofy, who help Uncle Donald mind the stores and assist him with his purchases.

To choose a skill level (beginner, intermediate or advanced) the player "walks" Donald through the appropriate city gate, into the town of Ducksburg. At the two upper levels, the games move a bit faster, but the duck earns more money for each chore completed.

Ducksburg is a storybook-perfect township, with a sparkling fountain in the middle of the city. On the left side of Main Street are stores where Donald can buy toys and playground equipment. But before he can buy anything, he must earn the money to pay for the purchases.

The right side of the street is lined with businesses where Donald can seek employment. Here, the ambitious duck gains fortune by sorting produce, unloading baggage at the airport, stocking a toy store, or working for Amquack Railroad.

Each of Donald's jobs are action-filled adventures. At McDuck Airlines, he gets a job sorting baggage. In a beautifully animated sequence, a plane lands, then taxis into the airport. Donald earns money by grabbing boxes labeled with three-

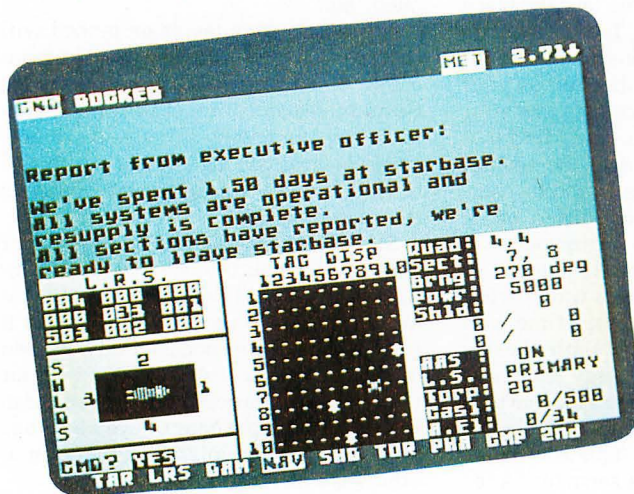

Keep the Federation safe in Star Fleet I.

letter codes as they pass on a conveyor belt across the foreground of the screen. Each package has to be tossed into matching receptacles, to be routed to its appropriate destination. Donald earns a few cents for each box correctly loaded.

The produce market is also hiring. Donald gets a job there, catching produce as it's thrown off a truck and sorting it into bins. Potatoes, grapefruit, strawberries, melons, pumpkins, and other fruits and veggies fly off the truck. The gamer maneuvers Donald under each one to catch the produce, then drop it into its appropriate crate.

Donald's job at the toy store is a bit more challenging. He's been hired to stock the shelves with new merchandise. To do this, he has to move a ladder to the spot where the toy belongs, pick up the toy, climb the ladder and place the toy on the shelf. Then he must climb back down, move the ladder to the correct spot for the next toy to be stashed, and do it all over again. But every time the Amquack Special passes through town, the rattling and rumbling of the engine makes toys fall from the shelves and break on the ground, and the cost of each broken item is deducted from the sad duck's earnings. Each time a train approaches, Donald must throw a switch to close a safety shield in front of the shelves.

The final activity—and the most advanced game, puts Donald to work as a switchman for the Amquack Railroad. The railway system fills the top half of the screen, with the train moving around the tracks like a computerized miniature. Donald operates a row of switches along the front of the screen and thereby routes the train, by shuttling it along the appropriate tracks.

To earn money, Donald also picks up packages in one city, as directed by the computer, then delivers them to their correct destinations. The child must quickly decide which route is best and quickest, then move Donald in front of that junction switch. Opening or closing the proper switches routes trains between towns, and Donald is paid for each package picked up and delivered.

The gamer chooses the length of time for each "work shift," then directs the action with control keys and mouse, joystick or ST number pad. The child can walk Donald around town, in and out of the stores (where he can look at objects, but can't take them until he has money to pay), or across the railroad tracks and into the city park. (The duck carefully looks

both ways before crossing the tracks, a subtle reminder to the child to always do the same.) In the park, the gamer finds one of Donald's nephews, anxious to frolic among the playground equipment that Donald can manage to purchase.

The real meat of the game comes on payday. After Donald finishes a shift, a payroll window appears. His hard-won earnings are carefully counted out, coin by coin. The child not only receives a lesson in work ethics (no work, no pay), but also gets an excellent tutorial in counting and handling money.

Each coin is carefully identified. When ten pennies are accumulated, five of them are turned into a nickel. Nickels add up to dimes, and coins add up to bills. By sheer force of repetition (Donald is paid after each and every work shift), the relative coin values are drilled into the player's mind, without the child ever realizing that there's a lesson involved.

The reward for the effort comes as soon as the child accumulates a few coins. Donald can visit Minnie's 5 & 10, Mickey's Hardware Store, or Goofy's Junk Shop, and select items for the playground. To make the purchases, Don signals that he's ready to pay, then the scene switches to the cash register screen. The child uses the on-screen cursor to move the funds, coin by coin, bill by bill, from Donald's stack to the cash register. If the player counts out too much money, the register will open to let the child make change. What a wonderful lesson in money management, money counting, and even work ethics and honesty!

The playground itself is a delight. The picture-pretty graphics extend over several screens, and Donald's purchases are delivered and installed automatically. Some of the equipment can be moved around the playground and placed where it's desired; others are fixed on their spot. Once the gamer has filled the playground with toys, it's a lot of fun to manipulate Huey, Dewey or Louie up and down the ladders, over the jungle gym, to swing or teeter or slide. Watching the little duck play is almost as amusing as the action skill games that earned the money for his toys.

**Donald Duck's Playground** is wonderful entertainment for children. The best thing about it is they'll never realize it's teaching them something; they'll be too enchanted by the games, the lovable Disney characters, and the charming town that forms a backdrop for this great educational program. //

## SBM ST

\$149.95

This system was designed to operate in a wholesale or retail Environment. SBM ST is an inventory control, point of sale program that produces invoices, purchase orders, statements, price labels, quotes, cash register receipts, inventory, sales and account reports, and more. Program Environment: Machine language. Search for accounts by number or name. Mailing labels printed for all or selected accounts and vendors. Sales reports consist of daily, periodic, and annual. Ten programmable tax rate keys. Track up to 30 salespersons. Capacities: Parts, Accounts, Vendors-32,000+ per file, unlimited files. Requirements: Atari ST system and printer. Options: Serial cash drawer.

Check your local dealer or contact:

Newell Industries  
602 East Hwy. 78  
Wylie, TX. 75098  
214-442-6612  
Dealer Inquiries Welcome

CIRCLE #131 ON READER SERVICE CARD

## WHAT IS ST-CHECK?

Most program listings in **ST-Log** are followed by a table of numbers appearing as DATA statements. We call them "ST CHECKSUM DATA." These numbers are to be used in conjunction with **ST-Check** (which appeared in ST-Log issue 11, February 1987).

**ST-Check**, by Clayton Walnum, is designed to find and correct typing errors when readers enter programs from the magazine. For those readers who would like copies of the article, you may send for back issue 11, for \$4.00.

## ST-LOG

P.O. Box 625, Holmes, PA 19045

# MasterPlan <sup>TM</sup>

## FINANCIAL SPREADSHEET

**MasterPlan** <sup>TM</sup> is an inexpensive, powerful, easy to use spreadsheet written totally within Digital Research's "GEM" operating system. MasterPlan utilizes extensively the graphics and mouse capabilities of the ATARI ST personal computer. HELP is built right into the program. You will be able to create worksheets and graphs within minutes.

### Atari ST <sup>TM</sup> Special Features.

- Mouse or keystroke operation.
- GEM interface with pull-down menus, icons, dialog boxes, ranging, scroll bars, column grabber, etc.
- Sparse matrix for conserving memory.
- Supports hard drives & printers supported by GEM.
- Supports color or monochrome monitors.
- Ultra-fast floating point math. Multiple windows for viewing graphs and worksheet at the same time.

### Spreadsheet Features

Reads/Writes .WKS data files, so MasterPlan will work with both Lotus 1-2-3 or VIP Professional data files. Giant 8192 x 256 spreadsheet grid. Date, Financial, Logical, Mathematical, Special and Statistical Functions. Cell and range operations. Cell and range naming. Cell Pointer expansion. Automatic, manual & natural recalculation. Optional display of formulas in cells. Print formatting options include printing borders, margin control, headers & footers, automatic pagination. Separately formattable windows. Frozen titles horizontally, vertically or both. Copy or move cell or range contents. Delete or insert rows or columns. Undo editing command. Protection of all or portions of the worksheet. Change column-width globally or with mouse. Import data from other business programs.

### Graph Features

Line, bar, stacked-bar, pie, and scatter graphs. "Exploded" pie graph. "UNDO" toggle graph. Displayable in color or monochrome. Up to six separate data ranges. Four different graph titles. Automatic or manual scaling. Symbols, line or data-labels for line graphs. Legends for labelling data ranges. Horizontal and/or vertical grids. Multiple graphs can be created and stored for each worksheet. Saves files compatible with DEGAS & Publishing Partner.

SYSTEM REQUIREMENT: Atari ST minimum 512K. 0.5 meg drive & color or monochrome monitor. MasterPlan is a trademark of DITEK International; Atari and ST are trademarks of Atari Corp.; GEM is a trademark of Digital Research Inc.; Lotus and 1-2-3 are trademarks of Lotus Development Corp. All specifications subject to change without notice.

Receive all the power of MasterPlan with color presentation graphs for only **US\$129<sup>99</sup>\***

\*Dealers may sell for less.

suggested retail.

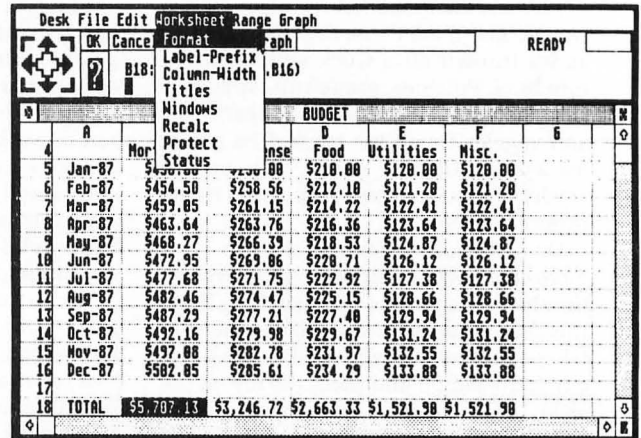

Home Budget Spreadsheet.

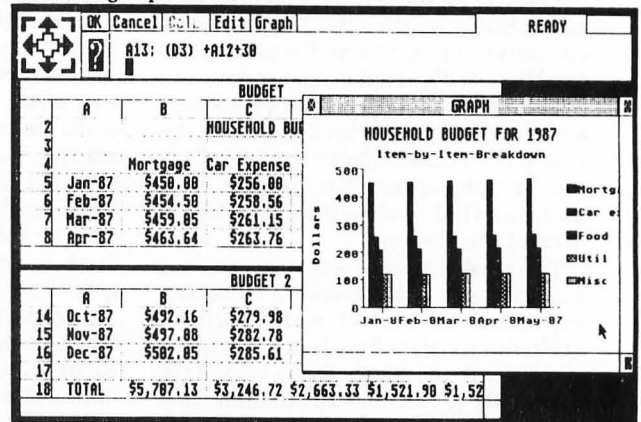

Home Budget, Multiple Windows With Bar Graph.

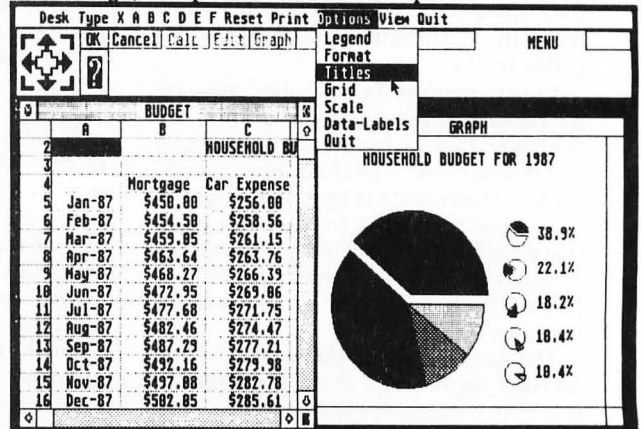

Home Budget, Multiple Windows With Exploded Pie Graph.

CONTACT YOUR LOCAL ATARI DEALER AND ASK FOR THE POWER OF

# MasterPlan <sup>TM</sup>

CIRCLE #132 ON READER SERVICE CARD

# Step 1

## PROCESSED PROSE

### A beginner's look at word processors.

by Maurice Molyneaux

I've been *dying* to use that subhead for months! Call it nostalgia, but my old column for my user's group newsletter was called "Processed Prose," and now I get to dredge it up one more time. Anyhow, we're back to some semblance of normalcy this month. The last two installments of **Step 1** were chock-full of only loosely related tidbytes of info, so it's nice to return to a single topic.

On to business. This time out, we'll discuss what I'd bet is the most commonly used of all computer application programs... *word processors*. In this article, I'll refer only to the two most common ST word processing programs: 1st Word and ST Writer. My observations on both programs are based upon the current versions I have of each (1.06 of 1st and 1.70 of ST, respectively).

#### Desktop publishing?

I'd like to make a distinction here. As this is the desktop publishing issue, you might assume this article is on that subject. Not quite. While word processing and desktop publishing can, and often do, go hand in hand, they're not the same. Desktop publishing software is designed to produce high-quality, usually "camera-ready" print. They feature special functions for page layout, graphics, borders, etc. A word processor is, generally, a program devoted to the creation, editing and printing of text. The output of a good word processor will have more in common with a professionally typed paper than with the camera-ready output of desktop publishing programs.

Please note that most desktop publishing programs can "import" text created with a word processor, so the two can be used in tandem. In fact, in many cases, it's a good idea to use a word processor to compose the text for use with desktop publishing software. This is because the word pro-

cessor's dedication to the task of composition and editing will usually make it a more powerful tool for composition than the simple text editors found in most desktop publishing programs.

#### It slices, it dices!

Just about every new user concocts some witty remark concerning the parallels of food processors and word processors. To the common man "processed" brings up images of cheese spreads, or Veg-O-Matics reducing a perfectly good apple (not computer, though that might be fun, too. . .) to mush.

In other words, if something's been processed, that means it's been pulverized or rended to bits, then reconstituted or reformed into something else. Apply this to writing, and the reaction you might come up with would be, "Gee, wouldn't it be neat to have a program tear my stilted writing apart and make it come out as uniformly consistent and smooth as Cheez-Whiz! In fact, maybe it would be fun just to watch it do the shredding part!"

Although the above is meant as a joke (as is usual in my bizarre comparisons), the truth isn't all that far removed from the peculiar example I've given. In fact, a word processor can be viewed as a kind of digital blender, but one with two settings: pulverize and reverse. A word processor can be used to tear down, destroy and rearrange the component elements of your documents—but, at the same time, can be used to assemble bits of text "mush" and form them into cohesive documents. Try picturing a food processor into which you dump spaghetti sauce—and out comes a whole tomato!

Okay, enough silliness. Word processors are programs intended for the manipulation of text. To many people, they seem to be nothing more than something to make your ST and printer act like a typewriter, costing half what the com-



## Step 1 *continued*

puter system did. If you've ever really used a word processor, it's a fair bet you'd never want to use a typewriter, no matter how good its features were.

Some years ago, when my experience with computers was limited to playing with the Atari 800 and 600XL of my siblings, I was looking for a tool with which to replace my recently deceased electric typewriter. Then I saw a beautiful Brother daisy-wheel electronic typewriter, with full-line correction and all kinds of other neat goodies. Well, I fell in love and some time later, when I was able to scrape up the cash, I bought it. Shortly thereafter, I purchased an Atari 800XL for graphics work. About that same time, I took a job doing computer work, which involved handling a word processor (WordStar).

Needless to say, my new typewriter, with all its shining points, paled next to the power of the program I used at the office. Within six months of purchasing my typewriter, I'd purchased a word processor for my 800XL, and gotten the necessary interfaces to make my typewriter act as a letter-quality printer (not all electronic typewriters can be so easily interfaced).

Consequently, since that time I've never actually typed on the typewriter's keyboard, except to make disk labels or jot a few lines on a note. All those wonderful features on the typewriter have gone to waste. I never use them, because they're easier to do with a word processor. When I bought my ST, I also got a dot-matrix printer, so my typewriter sees even less use than before.

Do you get the idea? The word processor made such a difference to me that something I had considered the tool of my dreams only months earlier quickly became an expensive and seldom used peripheral!

How can this be? What sinister powers do word processors command that they can sway writers to utterly abandon their first loves? Simple: a typewriter is merely a machine that prints characters. Even with all the fancy bells and whistles many of them have today, you *still* must retype entire pages or documents when you make changes of more than a line or two.

Sure, with a neat electronic typewriter you can delete words, or even reprint the page you just typed. But imagine dealing with a term paper, or a lengthy report, where information is being updated even as you finish the latest draft. Picture retyping whole bibliographies, tables of contents, or manually renumbering dozens of pages because you had to insert one or more early in the document.

You can do it all with a typewriter, but no matter how good a typist you are, you can do it *faster* with a word processor. Want to add a page? We'll just insert it here, and the program will automatically renumber all subsequent pages for the next print. Need to change one name to another? A quick universal "search and replace," and there we go. Let's have a cup of Earl Grey while the latest edition rolls out of the printer.

To bring this to a quick end, a word processor makes more *efficient* the task of writing and getting clean, error free copy. The most significant thing a word processor does is remove the physical "chore" of writing. Your train of thought is no longer broken because you have to listen for the right

margin warning bell, insert a new piece of paper, or whip out the correction fluid to snuff out a massive typo. Neither do you have to retype whole pages to get small changes. You don't have to cut and paste pieces of paper in order to rearrange things.

With a word processor, all you have to do is *write*, and any changes you want can be made while you're thinking of the next line. (In fact, I just fixed a typo while composing this line in the old gray matter. . . all in three seconds!)

Furthermore, a word processor almost begs for you to experiment. You can look back, decide that a word doesn't seem quite right, change it and, if it still isn't what you want, change it again and again—until you get what you want. You can move or delete whole chunks of text, see how the change looks and undo it if it isn't what you desire.

### **Standard equipment.**

Comparing a typewriter to a word processor is a bit like comparing a base model hatchback to a luxury sedan. A typewriter is a lot like that hatchback—stripped down, with almost everything being optional. You want line correction? You want variable pitches and auto-centering? You want anything but straightforward typing? Be ready to pay for it through the nose. They're all extras. But with a luxury sedan, in this case a word processor, they're standard equipment.

One of the most common—and welcome—things a word processor lets you do that a typewriter won't is give you the ability to insert and delete text, and work on any section of your document at any time. Suppose you type: *The ball is blue.* You suddenly realize that you must convey the size of the ball, so you want to change the line to read: *The BIG ball is blue.* No problem. Simply move your cursor to where you need *BIG*, make sure the insert mode of your word processor is on, and type away. The word *BIG* will push the rest of the sentence over, so you needn't retype the whole line.

Many word processors have a toggle to switch between "insert" and "replace" modes. In insert mode, everything to the right of the cursor is pushed along as you add text. If you toggle to replace, what you enter will obliterate whatever you type over. Not all word processors feature such a toggle. In fact, ST Writer programs previous to version 1.50 are *always* in insert mode, with no replace mode permitted. You must delete the text you wish to change, rather than just typing over it.

Most word processing programs offer a toggle to switch right margin "justification" on and off. What this means is that the program, knowing the width of your document's margins, will pad each line with the extra blank spaces necessary to make the right margin just as smooth as the left. In fact, the text in this magazine is justified. Both the right and left sides of the copy are at the margins; all lines, except at the ends of paragraphs, are the same length.

Chances are, your printer probably won't produce text as neatly and uniformly spaced as what you're reading here, so you'll have to experiment to see whether or not justification looks good on a given document. With justification off the right margin will be "ragged," each line ending wherever it will. This is different from proportional spacing,



which assigns characters of different widths spaces proportional to their size. Thus, the letter *M* would be wider than an *I*. Most word processors won't show this on-screen, but sometimes you can set your printer to do it.

One thing you need to know about word processors is that the RETURN key is *not* used in the same manner as on a typewriter. On a typewriter, a carriage return is used to move down to the next line when the current line has reached the right margin, or is completed. Thus, unless your typewriter features auto-carriage returns, you'll be striking RETURN at the end of every line on your document. This is unnecessary (most of the time) with word processors, because they feature what's known as "word-wrap." When you reach the on-screen right margin, you just keep typing. The computer will take the word which overflows the margin and automatically pop it down to the next line. The only place you need to press RETURN is at the end of a paragraph, or at the ends of lines where you don't want the word-wrap.

There's more to this system than just minimizing your use of the RETURN key. Since paragraphs aren't "broken" in midstream by carriage returns (which, in this case, force the cursor back to the left margin and down one line—known as a "carriage return-linefeed" combination), the program is free to adjust the text to fit into the margins if you change them.

For example, if you used RETURN at the end of every on-screen line, then decided you needed to make the margins narrower, you would have to manually insert new carriage returns, line by line, at the same time deleting the old. Imagine doing this on ten pages of text! Sounds perfectly horrible, right? But with word-wrapped text, all you need to do is change the margins, and the program itself will make all the necessary adjustments.

Please note that some programs do this automatically (i.e., ST Writer), while others require the user to signify when he or she wishes to reformat paragraphs (i.e., 1st Word). Such reformatting is necessary, not only when changing margins, but also when adding or deleting text. If you add six words in the middle of a sentence, they would surely push the following text past the right margin. Reformatting functions eliminate the trouble such changes could cause.

By the way, for paragraph indentions, some programs merely require you to press the TAB key, while others may use a special symbol to indicate the start of paragraphs, and will replace that symbol with a selected number of spaces when it comes time to print.

Other bits of standard equipment usually include the ability to specify page breaks, and page length and width. You can also set up custom header and footer lines that will automatically be printed on each page of text (where you might specify the page number, author, title, etc.). Look at the top and bottom of these two pages. "Step 1 continued" is the header, and the footer contains the page number, magazine name, and month and year of the issue. More powerful word processing programs will automatically create tables of contents and indexes, and feature special functions like footnoting. Unfortunately, footnoting has been ignored in every ST word processor I've used up until now.

### **Left, right, center, hut!**

Ever take a typing class? In order to center a bit of text, they teach you to move to the center of your current line and then backspace once for every two letters in the text to be centered. Easy to goof, and if you make a big typo, you might as well white out the whole line and do it again. Such effects are simple with most word processors. Usually, all that's required is to type the text, then press or click on a "center" command. The program will then figure out where to put the text so it's centered between the right and left margins. No more backspacing!

Another common function is right margin flush. What this does is take the line of specified text and pull it against the right margin, rather than the left. Not all word processors will do this, and, as far as I can tell, 1st Word is one of those that lack this feature.

Line spacing is often variable in word processors. Since you really shouldn't overuse carriage returns, you can't manually jam spaces in to get special distances between lines. 1st Word lets you choose between either single- or double-spaced lines. ST Writer lets you set any spacing you want—single, double, triple, etc.—as long as the spacing is in full lines. You must set the value in numbers of half-lines, but odd numbers are not accepted. You can't, therefore, set 1½-line spacing.

### **Typing out in style.**

With most typewriters, indicating emphasis on a word can be done in one of three ways: underline the word; type the word all in caps; or "mark" it with quotes. This isn't as professional looking, as what you'll see in books and magazines, where boldface and italics can be used for special emphasis. If your printer supports such text effects, you can probably get your word processor to tell it what to do. Some word processors support only a few text effects, while others let you do whatever you want.

1st Word allows you to use boldface, italics (skewed text), light, underlined text, or some combinations of those effects. However, you can't normally use variable type sizes, like elite and condensed type (between 12 and 17.5 characters per inch, or cpi, as opposed to the 10 cpi of the default pica type most printers use), expanded (double-wide) print, or subscripts and superscripts (small text above or below the horizontal centerline of a line of text). ST Writer does allow you to access these and many more effects.

Both 1st Word and the latest releases of ST Writer allow the user to type special characters not normally seen on the keyboard. However, just because you can type these doesn't mean they will print properly. Your printer's character set and your ST's are more than likely *not* identical.

Be warned that a number of text and other effects your word processor offers may not work with your printer. In some cases, the printer simply doesn't support the effect. But more often, your word processor just doesn't know how to tell your printer to activate a special mode or get specific special characters. This communication problem can usually be remedied by customizing the program's printer configuration data file (also called a *driver*).

Also, don't assume that, just because you obtain a printer configuration file that says it's for your printer, it will

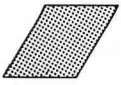

## Step 1 *continued*

work flawlessly. Many such drivers implement only some of the custom features of your printer, and may still need to be worked on.

For those of you who have been afraid to try creating a printer driver, or have tried and had trouble, the next **Step 1** will be devoted *exclusively* to that topic.

### **Hide-and-Seek.**

If you've done much writing, you're certain to have had those moments where you wished you'd put one piece of text before another. In such cases, most people either go on without doing anything, retype the affected pages, or resort to scissors and glue. No need when you have a word processor. You can simply grab the chunk of text that needs to be moved, and relocate it.

You do this by specifying start and end markers. The text between the markers is now a text "block" you can work with in various ways. You can move it to another location, make a copy of it elsewhere in your file, delete it, or even save it to disk as an independent file. In any case, the pages will automatically be restructured to fit the change. If you save the block to disk, you can, at a later date, load it, print it, or merge it into another file. If you decide not to act on the marked block, you can simply remove the block markers and forget it. (With 1st Word, you can use the Hide Block option.)

Now, we come to what is surely the most powerful function of most word processors. Since the text you type is, to the computer, only a mass of numbers, it can easily track down specific values, or even find those values and change them to something else. This feature is commonly called a "find" or a "search and replace."

Let's say you want to check to see if you've used the name *John Doe* in a document. You should go to the beginning or end of the file (so as to scan the *entire* document), call up your word processor's find command, type in the word you're searching for, and let 'er rip! If found, the cursor will move to the word in question. If not, you'll either get a message that the word couldn't be found, or be placed at the other end of the document from where you started.

Search and replace works much the same way, only you must specify, not only a word or words to find, but also what you wish to change them to. This is great if you realize, after finishing a document, that you've repeatedly misspelled a name or word.

When using such commands, you sometimes have additional options. You may, in most cases, carry out searches in either forward or reverse directions. You can also tell the program to automatically search and replace every instance of a word, or prompt you to see whether or not you want to make a change every time it finds the subject of the search. With 1st Word, you can even tell the program whether you want it to match the exact use of capitals and lowercase letters, or ignore the case.

A few helpful clues about these search functions: sometimes the program will find the word you're searching for imbedded in another word. For example, if you're searching for *car*, the program will find the *c-a-r* in *scarred* or *carried*. This could be a real mess if you perform an unprompted search and replace. My advice is to use a prompt-

ed search on such small words, or specify that you want to search for whole words only (if your word processor allows it). If you can't specify whole words, type spaces before and after the word when entering the subject of your search. Type SPACE*car*SPACE. This way, words like *scarred* won't be found. Of course, neither will *car.*, etc.

An additional hint for you speed demons: if you have to repeatedly type large or difficult to spell words in a document, make up an abbreviation to use when typing. When you're finished, search and replace that abbreviation with the full word. For example, you type 1W throughout your file, then search and replace it with *1st Word* (some reformatting may be necessary if your program doesn't do it automatically).

### **1st Word vs. ST Writer.**

If you're using one of these two programs, or have never used either, you may be wondering which is better. Well, I'm not going to tell you, because such comparisons are meaningless and admittedly subjective. What I *can* tell you is which program is better at certain things, and which one is best suited to specific users and tasks.

Both programs feature the most important "standard equipment." Both can type in boldface, italics, etc., center text, use headers and footers, and all that kind of thing. So, for the basic functions, both stack up equally.

Now, for those who need to be able to look at—or work on—two or more documents simultaneously, 1st Word is it. The user can have four documents open simultaneously in separate windows. ST Writer only allows one document in RAM at a time.

If you're an occasional user, who won't be doing massive amounts of writing, and like the "friendliness" of the GEM interface, again, 1st Word must be the choice.

Finally, if you like to see on screen pretty much what the page will look like, with all the special text effects visible as they will appear, it's still got to be 1st Word. Why? 1st Word is a "What You See Is What You Get" (WYSIWYG) word processor, displaying all the text styles and layouts as they'll appear when printed. ST Writer normally shows only control codes, and its print preview does not display text effects like italics, etc.

It may sound like 1st Word has it all over ST Writer, but that's not so. ST Writer is tougher to learn. All commands are issued from the keyboard, often involving cryptic button presses like CONTROL-G 1 to set bold pica type. The program features no windows, no menu bars and no helpful alert boxes. But, by not having these graphic niceties, ST Writer has something 1st Word doesn't. . . *speed!*

GEM is none too fast, and 1st's extensive use of it makes the program slow. Try jumping from one end of a large document to another in both programs. 1st Word takes a few seconds, but ST Writer is there in a flash.

Speed isn't the only important factor. ST Writer allows the user to punch in special printer codes from *within* a document, to do various things. For example, you can turn on your printer's slashed zeros for page 2, then turn them off for page 3. You can use almost any size print your printer supports (pica, elite, condensed, super- and subscripts, or expanded variations of these) while using effects like bold-

face or italics. You want boldface, expanded subscripts in compressed type? You've got it with ST Writer, while 1st Word just scratches its head in puzzlement.

Furthermore, since all the special effects in ST Writer are controlled by special codes which can be edited and deleted just like normal text, they can also be searched and replaced. Want to eliminate all the commands to start elite italics? Search and replace CONTROL-G 12 with nothing. All done! You can print double-column text (good for newsletters) and output special "spooled" text files, with control codes imbedded, which can be printed from the desktop without ST Writer being in RAM. All the special text effects you used will print, whereas they would normally be ignored when printing from the desktop.

In conclusion, if you're using either of these programs, or planning to, I'd suggest trying to obtain both. Give each one a try, and see which is best suited to your needs. And,

when you do choose one, keep the other anyway. You never know when you might want or need to use it.

### Energize!

Well, that's it for this month's expedition. As I mentioned earlier, next time we'll go over the basics of configuring your word processor's printer driver to work with your particular printer, and then we'll take a "test drive" to see how it works. Until then, may the Great Bird of the Galaxy roost upon your planet. *Beam me up, D.F. Scotty! //*

*Allergic to all things Commodore, Maurice Molyneux is an author/artist who—when not writing for ST-Log—continues to struggle with a recalcitrant 8-year-old science fiction novel, paints, illustrates and uses his ST for "every conceivable task." His interests include classic cel animation as well as the computer variety, and he draws the meanest "Star Trek" pictures on microcomputers. His Delphi username is MAURICEM.*

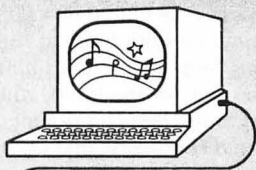

**Dr. T's™ MUSIC SOFTWARE**  
SERIOUS SOFTWARE FOR THE THINKING MUSICIAN

220 Boylston Street, Suite 306 • Chestnut Hill, MA 02167 • (617) 244-6954

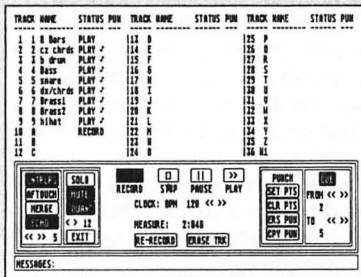

### KEYBOARD CONTROLLED SEQUENCER™ ST (KCS)

The ST-KCS contains THREE modes of operation:

**TRACK MODE:** an automated 48-track tape recorder using the mouse to select ALL major functions. It features a "continuous overdub" function allowing patterns to be built up layer-by-layer in REAL TIME with NO STOPPING!

**OPEN MODE** provides the generalized structuring system that the KCS has become famous for. 126 sequences are available which may be recorded on, independently looped, and chained together in ANY manner desired.

**SONG MODE** allows sequences created in Track or Open modes to be chained with a minimum of effort.

**OTHER FEATURES** are FULL editing of ANY MIDI event or parameter, extremely flexible CUT and PASTE, and many more edit options. STEP-TIME entry functions allow you to painlessly enter parts that you might be unable to play yourself.

		COMPUTERS					
		ATARI-ST	CGA/128	C128	IBM	APPLE IIe/+	MAC
SEQUENCER	PRODUCTS						
	KCS	*	*	*	*	*	
	MRS	*					
SCORING	VIEWS						*
	THE COPYIST				*	*	
COMPOSITION	CONVERTIFILE	*					
	ALGORITHMIC COMPOSER		*				
	ECHO PLUS		*				
	BACH SONG BOOK	*	*			*	
HARDWARE	DR KEYS/DR. DRUMS	*	*			*	
	DX-PATCHES	*	*			*	
PATCH EDITOR/LIBRARIAN	MODEL-T		*	*			
	CZ CARTRIDGES				*		
	DX-HEAVEN	*	*				
	4-OP DELUXE (TX81Z/F801/DX100/27/21)	*	*			*	
	ESQ-1	*	*				
	CZ-RIDER	*	*			*	
	CZ-PATCH	*	*				
	MATRIX-6	*	*			*	
	PCM 70	*	*				
	JX-8P	*	*			*	
KAWAI K3	*	*			*		
VDS (MIRAGE)	*	*					
WAVEFORM (MIRAGE)	*	*			*		
DX-PATCH	*	*			*		

Call or write for our free brochure.

**LIMITED ONLY BY YOUR IMAGINATION**

CIRCLE #133 ON READER SERVICE CARD

## SCHEDULED ATARI FAIRS

SEPTEMBER 19 & 20, 1987  
GLENDALE, CALIFORNIA  
Glendale Civic Center  
Sponsored by ACENET  
Contact John King Tarpinion at  
(818) 760-1831

OCTOBER 10 & 11, 1987  
WORCESTER, MASSACHUSETTS  
Worcester Centrum  
Sponsored by the BCS — contact  
Alan Glick at (617) 296-8286  
or ANALOG Publishing at  
(617) 892-3488

OCTOBER 24 & 25, 1987  
WASHINGTON D.C.  
Fairfax High School, Fairfax, VA  
(near Rt. 50)  
Sponsored by NOVATARI  
Contact Geogia Weatherhead at  
(703) 938-4829



their labs a year ago. Encore Systems and Sequent Computers have been using the NS32000 series in the designs of their multiprocessing machines for the last several years. Sabre Technologies is selling NS32032 workstations that perform at 1.2 MIPS. The NS32000 line has been—and still mostly is being—used in the designs of graphics boards, because of its higher throughput, more than any other microprocessor in the industry. National's microprocessor line is for real, and has been so for the last few years.

Lastly, National's manual may not indicate the clock cycles for each instruction; it was a generic reference manual for the entire line. (Can Motorola do this?) Clock cycles vary from chip to chip. "Experience then teaches one to look" at the data books for the clock cycles. The clock cycles of the NS32016/NS32032 instruction set are, generally, comparable to those of the MC68000 instruction set. The integer math instructions of the NS32000 series required fewer clock cycles.

Out in the industry, developers of the NS32000 line are reporting impressive performances. Byte magazine had an article on a 10-MHz NS32032 coprocessor board with one wait-state for the IBM PC. Byte's benchmarks reveal a performance comparable to a Vax 11/750. Another company selling a similar board without wait-states for the PC reported a performance comparable to a Vax 11/780. Encore Systems has a multiprocessing machine consisting of twenty NS32332s; the computer is benchmarked to go at 40 MIPS. With proper research, I am sure one can find more proof of the NS32000 series' performance in the industry.

One last note on the comparison of microprocessors. Besides a constant clock speed, similar data path widths, and on-chip caches, the MPUs compared should be of the same generation. Most microprocessor companies, including Motorola, placed the NS32032 as National's only 32-bit chip, and are unwilling to make any comparisons with the NS32332. Such a

comparison is incorrect. The NS32032 is of a previous generation. Motorola claims Intel compares "apples with oranges." In reality, Motorola is also guilty of the same action. A correct comparison would be:

MC68008, MC68000	1st Generation	NS32008, NS32016
MC68010, MC68012		NS32032
MC68020	2nd Generation	NS32332
MC68030	3rd Generation	NS32532

Raymond Chin  
Chelsea, MA

Okay, so send us a data book. This is the first time we've seen a lack of documentation adduced as evidence of the superiority of a hardware design; but that's progress for you.

As far as the 68000's "missing features" are concerned: there's always something missing. For instance, the 68020 lacks an instruction to calculate high tides in Kuala Lumpur during leap year. It's all how you look at it. The way we see it here, the 68000, compared to its then competitors, stands out head and shoulders, and all of us can only thank Atari for choosing it.

We're surprised by your remark about "incompatibility between the two chips" and the need for software emulation. The 68020 manual explicitly states that "the 68020 is object code compatible with the earlier members of the M68000 family." You may need to reassemble (or recompile) your source code due to extensions in the addressing scheme, and those silly enough to have used the top byte of the 68000 addresses will find themselves in trouble, but there's certainly no need that we can see for software emulation.

That sounds like a page from the Intel book. Thanks for your comments. —Ed.

### VIP notice.

The price and address given for VIP Professional in last issue's "Spreadsheet Comparison" were incorrect. Please note that VIP Professional is priced at **\$249.95**, from ISD Marketing, 2651 John Street, Unit 3, Markham, Ontario L3R 2W5, Canada. The phone is (416) 479-1880. Our apologies to all.

—Ed.

## Award Winning Software!

Winner of the Antic 1987 Outstanding Product Award!  
MT-CShell — \$129.95

You've heard promises about multitasking... But we've been delivering high quality multitasking for over one year!

Don't miss out on the new enhanced second generation of multitasking from Beckemeyer Development Tools!

- Installable device drivers increase functionality and flexibility.
- File and Terminal Control Functions are now available.
- Share hard disk files and resources with other users.
- Easy to Learn Unix-Like Operating System (similar to 4.3 BSD).
- Built-in print spooler allows you to work and print concurrently.
- Electronic Mail can automate your current communication system.
- Working Memory Manager eliminates erroneous "out-of-memory" messages.
- MT-C-Shell even fixes TOS I/O bugs.
- Free On-Line Customer Support on the BDT Forum (416) 462-4792.

#### Other Quality Products from BDT:

- ON-Line Manual (\$19.95) Documentation at your fingertips!
- VSH Manager (\$34.95) GEM Interface. Multitasking windows!
- MICRO C-Tools (\$24.95) Features, calendar program, calculator, text editor, find program and many more.
- AniTerm (\$24.95) Multitasking ANSI Terminal Emulator.
- Become a MICRO RTX registered developer for only \$250.00.
- Complete Beckemeyer Development Tools MICRO RTX System (includes all hardware and software) Only \$1,995.00.
- ADVANCED BUSINESS SYSTEMS — Call about our complete line of Multitasking/Multiuser Point-of-Sale Systems which include electronic cash registers, inventory control, and managerial reports with optional accounting package. Available NOW!

Beckemeyer Development Tools 416.462-1129 B.B.S. 416.462-4792  
478 Santa Clara Avenue, Suite 300, Oakland, CA 94610

CIRCLE #128 ON READER SERVICE CARD



# Status report

## When "new" gets old.

by D.F. Scott

The Summer Consumer Electronics Show, held annually at McCormick Place in Chicago, is a show not so much for consumers as for dealers, whose criteria for a product may range from estimated shelf-life and targeted buyer age to the impulse-buying potential generated by the color of the package. Products displayed this season varied in form, from pocket financial forecasting devices to the movie *Blood Frenzy*.

Each corporation rents a portion of one of this nation's largest show floors—contained within three buildings, one with two stories. Even with that much space, some exhibitors build temporary two- or three-story structures in the hall. Perhaps 100,000 people walk for miles within the mammoth halls, passing exhibits featuring such attention-catchers as scantily-clad bathing beauties and seven-foot dancing pocket calculators. The mood throughout CES is uniformly rosy, since the show signals the threshold of a new and burgeoning era in sales—an era which never comes. The "empirical data" quoted at CES proves not only that nothing can possibly go wrong, but that nothing has ever gone wrong.

Atari entered this (often) carnival-like atmosphere last June as the largest American computer manufacturer to show there. Competitors Apple and Commodore chose instead to show at the Computer Dealers' Expo, inconveniently scheduled at the

same time, in Atlanta—not many companies could attend both.

With Atari's dealer-advertising motto, "Flying High," waving atop subLOGIC's Piper, and its TV-advertising motto, "Business is War," playing on the tape machines below, corporate executives acted as salesmen. They displayed the ST to prospective retailers, professed the joys of incompatibility—offering their PC to those who didn't share that joy—and measured the impact their marketing scheme has on full-time salesmen.

We of the press, however, were measuring the effect those salesmen have on Atari corporate policy. We've reported before that Atari chiefs are openly reluctant to support the corporation's PC product. This reluctance is exhibited at the very top of the corporate ladder. If Atari as a whole doesn't want an 8088-based PC, why is it building one? If Atari retains faith in the XE as a veritable home computer, why is it repackaging that product as a game machine? Is Atari spending too much time *deciding* and not enough time *doing*?

Our **ANALOG Computing/ST-Log** CES team was: Publisher Lee H. Pappas, East Coast Editor Arthur Leyenberger, Midwest Editor Matthew J.W. Ratcliff, and yours truly.

We spoke to Sam Tramiel, Atari's President; Sigmund Hartmann, Executive VP and OEM (Original Equipment Manufacturer) Sales and Software Division Manager; Gershon Blumstein, International Software and Peripherals Marketing

Research Coordinator; Neil Harris, Marketing Communications Director; and John Rossi, President of Blue Chip Computer, one of the leading mass-market PC manufacturers (and a former Commodore employee under Jack Tramiel's command).

### Giving dealers what they want.

Neil Harris, at last May's AtariFest in Dallas, expressed the corporate mood about the PC: "The first time I heard we were going to do a PC, I said, 'What is it we're doing here? I thought we were trying to do good computers.' Our engineers feel the same way, that they're trying to push technology so these people can get really high-power computers they can afford. And here we are, regressing to six-year-, seven-year-old technology. On the other hand, you have to realize it doesn't take a lot of work to put out a PC clone these days. We had a couple of engineers working for a couple of months. The next thing you know, we had a product. You put a little bit of work into it, get the product out, and you make a lot of money—and you use that money to fund development of other things."

John Rossi of Blue Chip had a different point of view. When asked if repackaging the PC for the home market is merely a delay of its inevitable obsolescence, he responded, "I think that's really pushing it. There are something like 20,000 programs available for IBM compatibles. I think there's a tremendously large installed base. In fact, if you go back to the difference between 8-bit and 16-bit computers, the 16-bits were introduced rough-



ly five years ago and [1986] was the first year the 16-bits actually outsold the 8-bits, in terms of units. I don't think anybody would suggest [the 8-bit] is over the hill or dead. They're very, very suitable purchases for the home office."

If there is such a large installed base—if so many people own PCs—then wouldn't there be fewer people needing one? "In the case of my own company, I'm not trying to sell to people who already have units. We're trying to spread the market out to people who don't have a computer now, or have one they purchased a number of years ago. We think something like 85 percent of the market is untapped. Our steps are: number one, more powerful hardware at lower cost; plus our system of giving a helping hand to people who don't know too much about computing... to get people with no experience over that threshold.

---

*“... pressure from mass merchants [convinced] Atari to produce its PC.”*

---

"Nobody has to tell them about copy machines, because they're so easy to use. Computers aren't like that; they do require a period of training. Unfortunately, until now, it's been very frustrating for my company—and all the other companies in my category—to address the question of making the system easy to use for individual people."

It would seem logical that mass-market retailers and department stores, without many of the resources necessary to provide service after the sale, would invest in a solid, easy-to-learn system like the ST. The truth is, the ST has had difficulty making inroads in the mass market. It is the ST specifically which these retailers feel they can't sell—any more than they could sell a Hewlett-Packard or Apollo workstation.

Blue Chip Computer—whose sales have reportedly dropped, leading to a loss of some retail outlets—sells its machines through retailers who believe that the reputation of PC compatibles alone will sell the product. Sam Tramiel stated he feels "IBM compatibles sell in the mass market in toy stores. The analysis from our side: the toy stores or the mass merchants sell to the public that knows what

it wants and just buys a box. To buy an ST [one asks], 'What is an ST? What does it do? Explain it to me.' The store cannot explain it. You [already] have to know what you want."

Sam agrees the ST is the easier machine to use, but "the world doesn't know that."

What influenced Atari to produce its PC, according to Gershon Blumstein, was increased pressure from mass merchants, who wanted to compete with the Blue Chip and Amstrad dealers. This corporate lobbying reached the attention of Atari's general managers.

"General managers' subsidiaries [Atari's term for sales representatives] are God in their territories," explains Blumstein. "They're the ones responsible for the bottom line on what's going to happen. Essentially, it was a group decision: do you want it, or do you not want it? The group decision was: that's a market we want to sell into. Yes, some people are unhappy about it. Not everyone will be happy with all decisions. The effort hasn't detracted from the ST, but it's been a hard push."

Yet perhaps the project has detracted from the ST, on a psychological level. Atari showed no Mega STs at the Summer CES, nor any STs with blitter and the new TOS installed. The laser printers were also missing, although the longest-awaited product, the SX212 modem, did turn up attached to an XE.

There was one PC on display, with its new PCH204 hard disk drive and EGA monitor. It appeared the theme this season was not "where Atari is going," but "where Atari is now." The XE Game System commanded the second floor, other game systems assuming an indoor position within the nucleus of the "booth." The STs surrounded the nucleus like supercharged electrons.

Sam Tramiel closed Atari's case against its own product, admitting, "I hope the PC doesn't do so well. We're going to make the PC, since there's a gigantic market for it. The STs and the 8-bits are our bread-and-butter. They're what we're going to be pushing as hard as we can."

It looked embarrassing at times to have been a corporate executive "pushing" the ST—since every new ST enhancement announced at the Winter CES, that was supposed to have been released before the Summer CES, was not. Did the PC delay Atari's plans for the ST product line, or were those new products just announced too soon?

### **Would you believe next year?**

The single most common criticism

against Atari is what enthusiasts at the Dallas AtariFest described vehemently as its trend toward sloth.

Atari's defense, up to this point, has either been silence or retaliation—both of which are rather difficult to typeset, let alone quote.

Almost everyone at Atari HQ believes the main corporate problem is, not developing products too slowly, but announcing them too early. Surprisingly, the man upholding this view is Neil Harris, who, in discussions with Atari enthusiasts, has been the brunt of bad jokes. "It's at the point now," Harris says, "where I call home and my little kid gets on the phone and says, 'Hi, Daddy, I miss you; where's the Mega ST?' It's like that on Genie and Delphi, too. If you wait for it every day, or you watch the stock every day, you go crazy."

"The PC announcement," maintains

---

*“... the main problem is, not developing products too slowly, but announcing them too early.”*

---

Sam Tramiel, "was the strategic thing to do to raise the stock [value]."

The PR firm Amidei and Company, in the future, will be handling much of the work that previously weighed down Neil Harris's desk. Still, there's a lone advocate of the "controlled leak" method of spreading new product information. Said Harris in Dallas, "Sam Tramiel once said we shouldn't announce any products before they're actually ready to ship. Then he had a change of heart. It's an ongoing problem, figuring out when things are going to be ready."

Sam Tramiel, referring to a German computer magazine, suggested "the computer industry [become] like the car industry. [You] don't announce a car until you're ready to ship it; but magazines make sneak previews, take photographs behind the fence and spy on the cars—and make rumors. If it should become a rumor announcement, then you make the official announcement."

Gershon Blumstein—whose business is now peripherals—admits it's Atari's desire not to be competitive in peripheral production. "We're not going to have a

whole slew of peripherals," he says. "What we're going to do is take areas that make sense for the customer, for broad-base distribution. We're going to meet people's needs, but we're not going to go out and step on other people's toes."

So, if Atari isn't in the peripherals business as a serious contender, then what will the Mega ST—the computer built for peripherals—do?

#### **Insert Idea A into Slot B.**

If Atari didn't intend to enter the peripherals business, why build the Mega at all? With Shiraz Shivji's Research and Engineering division working on standard interface connectors and networking cards (which no one outside his division has bothered to mention), could Atari be pumping too much energy and money into production that will prove to have been pointless?

About the future capabilities of the Mega, Neil Harris says, "That's up to everybody. One of the things you can do is create a board that can support a Motorola math coprocessor, which we'll probably be selling ourselves. Economically, it's not feasible for a company to support every possibility. When we ourselves look at the marketplace, see a product and say, 'This is really neat, but we can only sell 500 of them'—are we going to do it? No, not for 500.

"There's a certain threshold. With an add-on board for a computer, that's a market we're not terribly interested in. What we're going to do is publish the specs for the bus—basically the 68000 processor bus with the addition of a few interrupt lines—and say, 'God bless you all out there,' because there are a lot of companies that know how to make boards."

The job of finding new outside peripherals to support from the inside belongs to Gershon Blumstein. "The way you get kicks into a product," he claims, "is by doing promotions; add peripherals to the product, to give it the kick. Essentially, in the hardware business, they put out a piece of hardware, then provide an operating system that's more usable, then come up with applications, then come out with a printer and peripherals.

"The whole story is: system solution. So we're providing more and more peripherals to make it a complete solution. One-stop shopping, one vendor solving your needs—you don't have to go from here to there, to there, worrying about solutions. Atari will take care of you. This is very prominent in the industry: IBM does it, Apple does it, HP does it."

Software production—Blumstein's former title—has now fallen back into the hands of Executive VP Sig Hartmann. Instead of using an internal programming team, Hartmann will seek out "productivity packages" from independent ST software developers.

At a meeting of such programmers in Chicago, Hartmann says, he told them their primary direction should be "to concentrate on high-level packages. We now have 1,243 software packages on the ST. A hell of a lot of it is duplication; but many of those software packages were written, initially, when the guy learned our machine. So, I would say, the quality is acceptable; but it isn't the high-end, quality software.

"I said, look at Excel. That's a high-end product. Now that we're coming out with the Mega machine—2-meg, 4-meg, desktop publishing—we're going into the vertical marketplace. We need products like Excel, products like those of Lotus and Ashton-Tate. But what we're looking for is an improvement, something that makes ours different from the products out there—the next generation product level."

---

*“Weighing in Atari's favor. . . its first quarter figures for 1987—a 411 percent increase over last year's first quarter.”*

---

If the software product was good enough, said Hartmann, the producer might have the option of selling the entire ST hardware package, bundled with their software, as a VAR (Value-Added Reseller). Atari would provide the tools and training. For those developers interested in this course of action, Atari will ship a new developer's kit soon, which will replace the DRI Alcyon C compiler with Mark Williams C.

As for signing on any larger VARs, it's the lag in production that slows down Hartmann's job. In order to negotiate an agreement, he explains, "You have to have a product ready to sell. I don't have a 2-meg Mega machine, I don't have a desktop publishing system available today. So it becomes very difficult to get ComputerLand, and all the rest of the guys, to sign a contract. But I think, this coming fall,

we'll have all of ours ready. We're definitely making the right inroads with those people. They expressed an interest; that's why we're talking to them."

#### **Meanwhile, back in the vault . . .**

The one piece of convincing "empirical data" weighing in Atari's favor is its first-quarter figures for 1987, which are beginning to be an echo of the boom days of Raymond Kassar and Asteroids Deluxe: \$65,133,000 in sales, with \$9,365,000 of it in net income—a staggering 411 percent increase over last year's first quarter. Earnings per share also quadrupled—32 cents per share. If the company's doing something wrong, it doesn't show here.

Yet the production scheduling/public announcement snag still exists, and the resulting internal tumult is at its worst. The solutions, however, may be underway—in the form of the new PR firm, the new U.S. factory, and a new grey packaging scheme called the XE Game Machine (issue 57 of **ANALOG Computing** covered it in detail).

"Business is War," Atari's new TV ads state. If this is the war, we asked Sam Tramiel, where's the ammunition? "We're like Montgomery in the war in Africa," he answered. "We want to have an overwhelming army before we attack."

That's **Status report** for this month. I'll see you on Delphi. //

---

### **SOPHOS CHESS!**

ATARI ST 3-D GRAPHICS.  
SELECTABLE MODES AND  
LEVELS OF PLAY.  
COMPLETELY MOUSE DRIVEN!  
SIMPLE TO USE! AUTOMATIC  
CASTLING UPON REQUEST.

**ONLY \$22.50**

SEND CHECK OR MONEY ORDER TO:

**SOPHOS CHESS  
P.O. BOX 166  
EAST MANSFIELD, MA 02031**

(617)339-0884

PLEASE ALLOW 1-2 WEEKS FOR DELIVERY

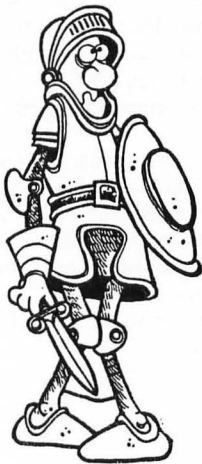

## ST news, information and opinion.

---

by Ian Chadwick

---

Computer applications seem to me to appear as great waves that crash into our lives and change the way we do things. Word processors, databases and spreadsheets—all have had a remarkable impact on not only our commercial lives, but our private lives as well. The majority of the people I know use a computer at home, and many have moved into full-time freelance jobs because of it. The computer hasn't brought us a new industrial revolution—it's more like a full-scale civil war.

Desktop publishing (DP) is the latest wave to hit the beaches and one of the most important thus far. Actually, the term is misleading—it sounds as if there's another form of publishing that takes place away from desks—maybe stovetop publishing? Anyway, Gutenberg's mechanization of the printing process was the seminal event in the evolution of information processing—and DP is a major milestone along that route.

Sound pompous? Yeah, it does to me too. But I'm serious. The crux of the entire issue—with computers and, indeed, with the whole information exchange process—lies in the computer's ability to put the control of such things in the hands of the user. This is precisely what the printing press did with the written word. The art of the scribe was soon a lost art.

Of course, new technology demands new skills: typography, typesetting and printing quickly became crafts in their own right. With the advent of electronic

typesetting, a lot of the composition skills were assumed by graphic and layout artists, while the actual setting of type became more of a mechanical process. Typographers, nowadays, are a rare breed.

Word processors, computer typesetters, digitizers, graphic and paint programs, telecommunications—all have been used in the preparation and production of books, magazines and newsletters for years. DP programs synthesize all of this, along with a host of other features: page layout, document control, pagination and effective printer control. DP programs are, perhaps, the most sophisticated, complex software yet to appear.

It helped DP software that a simultaneous wave was cresting in printer development. But let's face it: dot-matrix printers—even the superb 24-pin machines—are simply not good enough for final output at any professional level, period. They can't do real micro-spacing, kerning or vector graphics. They're great for home-grown output—user group newsletters, self-made greeting cards, Print-Shop-type stuff—but nowhere near good enough for books or magazines. Then again, neither are most laser printers. Even the highly touted Postscript printers with a resolution of 300 dots-per-inch (dpi) are still at the low end of acceptability for commercial output. Most publishers demand 600 dpi—or more—for even straight text.

I've recently been working with a 1200-dpi Printware laser printer, and that's about as coarse as I'd ever care to get for anything involving graphics. Its output is easily recognized as a computer product



# Ian's Quest

by anyone with a magnifying glass. Since laser printers with 600 or higher dpi are currently few and far between, and those that are available are rather expensive, DP tends to remain outside the economic range of the casual user. Today, at least.

Be that as it may, the various models of Hewlett-Packard's LaserJet have cornered roughly 70 percent of the laser printer market. With the "inexpensive" entries into the field by Canon and Ricoh, it seems likely that people will be buying these printers than the more expensive Postscript compatibles, which may offer more versatility, but at a higher price. Publishing Partner supports HP, but none of the others (as far as I know) do.

A key selling point for DP programs is their automation of tedious or complex layout and typesetting processes. Here, *tomation* is the key word. That's where Publishing Partner fails to meet its promises in many areas.

Take a look at kerning, for example. Kerning is the reduction of space between certain pairs of characters, so that they're more visually attractive. Some of the more frequently kerned pairs are: Yo, We, To, Tr, Ta, Wo, Tu, Tw, Ya, Te, P, Ty, Wa, yo, we, T., Y., TA, PA and WA. In the example of Yo, kerning reduces the space between the two so that the o is actually underneath the upper limb of the Y. In practice, most DP programs kern over 200 pairs, but more than 500 are used in most typesetters.

Kerning is now a regular practice in typesetting. It not only makes the flow of type more attractive, by reducing unnec-

essary white space, but it tightens up the lines of text themselves, allowing far less wasted space.

Let's talk about Publishing Partner. It's a great, fun program for homebrew output. My friends at Atari Canada do a reasonable job with it to produce their educational newsletter, but it won't win any design awards. Don't get your hopes up if you're planning to create and format your great novel on it—the program's a long way from capably handling any lengthy professional-level document.

Publishing Partner has only manual kerning—a task simply beyond comprehension in a book-size publication. Curiously enough, it's not even indexed under kerning; it's under "manual kerning." I can't determine the amount of space the kerning applies or removes; it appears to be in points, a grossly large amount for kerning.

Kerning, like many typesetting functions, works best on the basis of a text-size-relative unit of measurement, not an absolute one. For example, the commonly used "point" ( $\frac{1}{72}$  inch) is a typesetter's and printer's absolute measurement. But type is often dealt with in *Ems*. An Em is a square equal in width to the total height of the type (so a 10-point Em is 10 points on a side). [For more on type height, refer to Figure 4 in "Page Perfect," on page 50.] This is broken down into *Ens* (one-half Em), *thins* (one-third Em) and *Units* ( $\frac{1}{54}$  Em). The characters are usually kerned in Units (or a percentage of the space between them), not in points.

Yes, Publishing Partner allows a certain

amount of control over the spacing between characters (in Units, it turns out—the only place I can see that Units are used in the entire program—and they're poorly explained, at that), but only on highlighted text. Nothing can be automatically applied to an entire article or chapter. Unfortunately, their elegant little dialog box for adjusting the character spacing uses one size of text—not what's necessarily chosen on the page—so the effect is achieved by trial and error.

Line spacing—more commonly called *leading*—is adjusted in the same box. I can't figure out if it's measured from baseline to baseline, baseline to ascender, or descender to ascender. At least I know from the display that it's in points. Despite the nicety of negative leading, I wonder why they bothered with such an enormous range, when the effect has limited practical value and is absolutely wasted if the negative spacing exceeds the point size. A negative leading of 42 points on 11-point type is just plain silly.

If the terminology is confusing, you'd better learn it fast. DP is based on typesetting and printing terms. I doubt most people would readily understand what's meant when I talk about type that's *10 on 12*, or *set solid*, or *minus leading*—yet they all involve the simple process of line spacing.

What about *Pi characters*? *Drop caps*? *Gutter widths* and *gutter rules*? *Text greeking*? *Serif* and *sans serif* typefaces? *Bullets*? *Set size*? The difference between a *font* and a *typeface*? *Quadding*?

You can't really discuss the issues with-

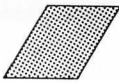

out understanding the jargon, any more than you can discuss auto mechanics without knowing the names of engine parts. Of course, there's no glossary in the program to help you learn this new vocabulary. Better start reading other books on the subject, if you want to appreciate what this is all about!

Measurement is another issue: Publishing Partner is dependent on the printer's line resolution. But typesetting demands exacting control. Can you create a *hair-line* or *half-point line* with your printer? What happens when the line is on an angle? Does it look more like a staircase? This is where both resolution and vector graphics become important. Publishing Partner supports lines from .5 to 6 points, but finer control would be appreciated—something more closely linked to a laser printer output.

The handy metal ruler used by typesetters and graphic designers has been replaced by a screen ruler. A nice idea, but not carried through as needed. Rulers need a wide variety of measurement units, but you only get picas (1 pica= 12 points),

inches and centimeters. Everyone I know in the printing business deals in points. Many of this program's measurements are in points also, but you have no accurate way to measure them. Anyone doing precise work on a laser printer soon learns to work in its resolution—dots. Many printers have a 300-dpi resolution, so users need a ruler in that scale, as well.

The rulers are at the top and left sides of the screen, which means measuring an object requires moving the page to the ruler, rather than the other way around. The rulers are absolute to page edge—you can't set the starting point to suit your page design. And, finally, you don't have "floating" rulers to measure diagonal objects on the page.

Character sizes are limited to full-point increments (some programs allow half-point increments). The maximum character size is 72 points, which is probably as large as most people ever need, but banner headlines sometimes exceed that. Adobe's PostScript fonts go up to 255 points—you won't be able to use them, however.

Hyphenation can be a serious problem. Since we're dealing in variable width structures, such as columns, there's no way to guarantee that the lines of text imported from outside editors will properly fill the lines. A hyphenator that can properly divide words is absolutely essential for newspaper, newsletter or magazine output—actually any output that uses both right and left justification. The many rules of hyphenation are complex, and having to apply those rules over long text is a tedious, unrewarding task—a task you must assume with Publishing Partner, unfortunately.

An important selling point in DP is its ability to create *text runarounds*. These happen when you drop graphics into a text area, and the text breaks and flows around the graphics. Line breaks and hyphenation change to suit the graphic's border. No can do in Publishing Partner—at least not automatically. You can wrestle with column margins and simulate the effect, but it's not the same.

Perhaps Publishing Partner's greatest weakness is in its handling of pages and columns. First, you'll have to decide—before you load the text—how long the document will be, then delete extra pages later (something that drives users crazy in PageMaker). But worse, when you go to all the trouble of creating a complex layout—say, a two- or three-column page—then fill it with text, you're stuck with it. If you want to move column one a few points left, you have to manually adjust each one on each page. Nothing automatic here, folks—it's often easier to throw your design away and start again.

This program has a lot of nice, elegant and handy features: plenty of file and disk commands, graphic features and a bunch of ways to fool around with type. It also supports page sizes up to 18 inches—a nice touch, even if you can't tile-print on a smaller page size.

Publishing Partner is above Print Shop and that lot, but can't stand knee-high to Ventura, PageMaker, Harvard Publisher or The Office Publisher—the big guns in the DP marketplace. Maybe version 2.0? We'll see. . . //

*Ian Chadwick is a Toronto-based writer who currently works in the desktop publishing industry. He's been an author, book editor, magazine editor and roustabout in the publishing business for many years. In his spare time, he brews his own beer and plays wargames.*



We have no real reason to put this here; our staff just likes the guy. —Ed.

## K-Series Software by KUMA

- |                       |                      |
|-----------------------|----------------------|
| K-Switch              | K-Word <sup>2</sup>  |
| K-Spread <sup>2</sup> | K-Data               |
| K-Spell               | K-Graph <sup>2</sup> |
| K-Comm <sup>2</sup>   | K-Minstrel           |
| K-Seka                | K-Resource           |

AVAILABLE THRU

### ScanAm Enterprises, Inc.

P.O. Box 1145  
Ridgewood, NJ 07451  
201-445-5260 or  
800-524-0484

*Call or write  
today for catalogues*

CIRCLE #112 ON READER SERVICE CARD

# C-manship

## Still more on windows.

by Clayton Walnum

In our last GEM experimentations, we learned some of the basic functions used to manipulate windows. We discovered how to initialize, open and close a window, as well as draw its interior (the work area), and handle the messages GEM sends to our application when the user wishes to move the window or make it full-size.

As I'm sure you've guessed, there's still more to learn before we can call ourselves window experts—a *lot* more. We still need to know how to handle many other types of window messages, not the least of which is the redraw message. We also need to know how to use the window's sizer button, scroll bars and arrow buttons. And then there's the matter of multiple windows!

Relax. We're not going to cover all that material this month; we'll save some for the future.

### This month's demo.

Type in the sample program shown in Listing 1 and compile it. (Disk subscribers need only run the WINDOW2.PRG file found on this month's disk version.) Note that the listing was developed with Megamax C. If you have a different compiler, you may have to make some minor changes to the code.

When you run the program, a full-screen window containing some text will be opened. You can drag the window around the screen by placing the mouse pointer on the title bar and holding down the left button. You can change the size of the window, using the mouse to click and drag on the sizer button. When you're through experimenting with the window, exit the program by clicking the closer button.

It doesn't seem as if there's a lot more going on here than in last month's program, does it? But there is...there is...

### Any size you like.

The GEM window form provides a button used to set a window to any size the user requests. When the user activates the sizer button (by click/dragging it), an outline of the window appears on the screen. The outline expands and contracts with the movement of the mouse pointer—as long as the left button is held down. The moment the button is released, the window is redrawn at the size selected by the outline.

Handling the sizer button is simple (well, there are a couple of complications we'll get to in a minute). First, of course, when initializing the window, you must tell GEM to include the sizer button in its parts list. Then it's just a matter of waiting for the `WM_SIZED` message and using the call:

```
wind_set ( msg_buf [3], WF_CURRXYWH,
           msg_buf [4], msg_buf [5], msg_buf [6],
           msg_buf [7] );
```

This sets the window's current size to that returned in the message buffer. (If you've forgotten how this message stuff works, review the last couple of *C-manships*.) Easy.

However, (have you noticed that there's always a "however"?) there are two things we have to watch out for. The first is a redraw message. We will receive one of these when the window is moved from a partially off-screen position back to the desktop, or when it's increased in size, either horizontally or vertically. Also, it's up to us, the programmers, to keep the size of a window within certain limitations.

The maximum size of a window really isn't a problem. The window will never be larger than the desktop, anyway. It's just nice to know that, if we ever decide we want the window kept below a certain maximum size, we can.

The minimum size, however, is important. If we don't check the requested size of the window before setting it, we may find we've left the user with a tiny, unusable blob

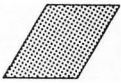

on the screen. It's the programmer's responsibility to make sure the window isn't set to a size too small to contain the parts needed to function.

Take a look at the `do_wndw()` function in Listing 1. It's here that we handle the messages GEM is sending us. You'll notice that both `WM__MOVED` and `WM__SIZED` messages are dealt with the same way, via a call to our function `do_move()`. The reason is that both these window events are handled with the `wind_set()` call.

In the function `do_move()`, the first thing we do is check the requested window size, returned to us in `msg_buf[4]` through `msg_buf[7]`. If the height or width of the requested window is smaller than the minimums we've set (the actual values can be found in the `#defines` at the top of the listing), then we replace the unacceptable values with our minimum values. The user can try to set the window as small as he likes, but it will never be drawn at a size smaller than our minimum.

If we need to control the window's maximum size, we would do it the same way, adding another set of `if` statements to check for compliance with whatever maximum values we wished to force on the window.

### Redraw messages.

As we move our window around the screen, and as long as we stick to certain limitations, GEM is perfectly happy to redraw the window and its contents for us. But there are times when GEM stops right in its tracks, scratches its silicon head and says, "Here! You figure it out!" To understand why this happens, we need to know a little about how GEM does its window tricks.

Basically, GEM has no trouble redrawing a window's contents (its work area), as long as all the data needed is present on the screen. For instance, let's say we've drawn a small window in the center of the screen and filled the work area in with a white background. Now we move that window a little to the right. GEM can redraw the window because all the information it needs is still on the screen. When it does the redraw, all it does is "blit" the old screen information to its new location. The complication begins when we do one of two things with our window: move it on to the screen from a partially off-screen position, or enlarge it.

In both of the above cases, as I'm sure you can see, the information GEM needs to redraw the window isn't available on the screen. It will make the attempt and redraw as much information as it can, but when it gets to the missing data, it'll give up and tell us to handle it, by sending a redraw message.

This description is, of course, an oversimplification. Things get much more complicated when you start dealing with multiple windows, since any movement of the active window (the topmost window) will surely result in redraw messages for some or all windows underneath.

Redrawing a window is not, unfortunately, a simple process. To do it properly, you must perform the following steps:

- (1) Lock the window for an update.
- (2) Get the first rectangle to be redrawn from the rectangle list.
- (3) Check if the rectangle returned from the redraw message (stored in `msg_buf[4]` through `msg_buf[7]`)

intersects the rectangle obtained from the rectangle list.

(4) If there's an intersection, set the clipping rectangle equal to the rectangle obtained from the rectangle list, and redraw the window.

(5) Get the next rectangle from the rectangle list.

(6) Perform steps 3 through 5 until the rectangle list is empty (width and height both equal to 0).

(7) Unlock the window.

Sound like fun? Let's take an in-depth look at each step.

### Lock the window.

The first thing we must do before updating a window is lock it away from GEM. This prevents the user from doing anything to "pollute" the screen—such as activating the menu bar or a desk accessory—while trying to get the window redrawn. Essentially, it stops two applications from writing to the screen at the same time. To lock a window, we use the call:

```
wind_update ( BEG_UPDATE );
```

The integer `BEG_UPDATE` (defined as 1) tells GEM we're going to start updating the window and that other writes to our window should be disallowed. The `wind_update()` call also supports three other functions, depending on the value of the flag. The four flags and their values as defined in the `GEMDEFS.H` header file are as follows:

<code>END_UPDATE</code> . . . . . 0	Unlock window
<code>BEG_UPDATE</code> . . . . . 1	Lock window
<code>END_MCTRL</code> . . . . . 2	Lock mouse control
<code>BEG_MCTRL</code> . . . . . 3	Begin mouse control

### The rectangle list.

In order to facilitate redrawing, GEM divides each window into a series of complete rectangles, then stores the coordinates of these rectangles in a rectangle list. We'll be discussing the rectangle list in greater depth next month, when we start working with multiple windows; for now, it's enough to say that each time we get a redraw message, we must read each rectangle in the list, compare it to the rectangle returned from the redraw message, redrawing those rectangles that need updating.

In Listing 1, the function `do_redraw()` demonstrates how to handle the rectangle list. We get the first rectangle in the list with the call:

```
wind_get ( msg_buf[3], WF_FIRSTXYWH,
           &x, &y, &w, &h );
```

Here, the integer `msg_buf[3]` is the window's handle (returned from the redraw message) and `&x`, `&y`, `&w` and `&h` are the addresses of integers where the coordinates of the rectangle will be stored. The flag `WF_FIRSTXYWH` is defined as 11 in the `GEMDEFS.H` file.

We know we're at the end of the rectangle list when both `w` and `h` are 0. So, after getting the first rectangle, we enter a while loop that tests for this condition.

Once we have a rectangle, we must test to see if it lies within the "dirty" area of the screen (usually the full area of the window that generated the redraw message). We use the call:

```
rc_intersect ( rec1, rec2 );
```

Here, `rec1` and `rec2` are pointers to data of type `GRECT`. This returns a 0 if the rectangles don't intersect, and a 1 if they

do. GRECT is defined in the GEMDEFS.H file and is nothing more than a structure whose members consist of four integers: the X- and Y-coordinates of the rectangle, and its width and height.

### The clipping rectangle.

If the two rectangles intersect, we've found an area of the screen that must be redrawn. In order to be sure the data we're going to write doesn't overflow its window, we set a clipping rectangle.

A clipping rectangle confines all writing to a specific portion of the screen. Anything that we try to draw outside of this area will be "clipped" off. Once we've set a clipping rectangle, we don't have to worry about figuring out exactly what to draw and where; we just redraw the entire window and let the clipping function do the hard part.

To set a clipping rectangle, we use the call:

```
vs_clip ( handle, flag, pxy );
```

Here, handle is our application's handle; flag is an integer that, when FALSE (0), turns clipping off, and, when TRUE (1), turns clipping on; and pxy is a pointer to an array of four integers where the coordinates of the upper left and lower right corners of the clipping rectangle have been stored.

See a small problem? The rectangle we want to redraw is given to us in the usual AES form of X, Y, width and height; yet the clipping rectangle must be set using the VDI type of rectangle form. That's why, in our function set\_clip(), we first have to do some simple conversions.

Once the clipping rectangle is set, we just redraw the window's interior, letting the clipping function figure out where and where not to place data. When we're through updating the window, we call vs\_clip() a second time with flag set to FALSE to turn off clipping.

### Emptying the rectangle list.

To be sure we've updated the entire screen (wherever it needed it), we must "walk the rectangle list." That is, check every rectangle in the list against the rectangle returned from the redraw message. To get the remaining rectangles in the list, we use the call:

```
wind_get ( msg_buf[3], WF_NEXTXYWH,
           &x, &y, &w, &h);
```

The parameters here are the same as for the call we used to get the first rectangle, except that the flag is now WF\_NEXTXYWH, which is defined as 12 in the GEMDEFS.H file.

We continue pulling rectangles from the list and redrawing them, if necessary, until the width and height values we get are both 0. At that point, we know we've checked all the rectangles.

Once we've completed the rectangle list, the only thing left to do is unlock the window with the call:

```
wind_update ( END_UPDATE );
```

### Something of interest.

At the top of Listing 1, we've defined the text we need for our window work area like this:

```
char *text[] = {
    "This is some sample text",
    "for use in the C-manship",
    "window demonstration found",
    ""
};
```

```
}; "in ST-Log, Issue 17."
```

This is a way to simulate string arrays in C. The array text[] is actually an array of pointers to character, each containing the address of one of the strings found within the quotes. The element text[0] contains the address of *This is some sample text*; element text[1] contains the address of *for use in the C-manship*, and so on.

In Listing 1, the function draw\_interior() shows how to access this array to print the text to the window. We simply use a for loop to advance through each element of the array, while in each iteration of the loop, we use the current array element as an argument to v\_gtext().

### The agenda.

That's enough book work for this month. Next time around, we'll look at some sample code for handling more than one window at a time. We'll also dig deeper into this confusing rectangle business. And, who knows? Maybe we'll find some other trouble to get into, as well. //

Listing 1.  
C listing.

```

/*****
/* C-manship, Listing 1
/* ST-Log #17
/* Developed with Meganax C
*****/

#include <gemdefs.h>
#include <obdefs.h>

#define TRUE 1
#define FALSE 0
#define PARTS_NAME|CLOSER|MOVER|SIZER
#define MIN_WIDTH 64
#define MIN_HEIGHT 64

/* GEM global arrays */
int work_in[11],
    work_out[57],
    pxyarray[10],
    contrl[12],
    intin[128],
    ptsin[128],
    intout[128],
    ptsout[128];

/* Global variables */
int handle, fullx, fully, fullw, fullh, wrkx, wrky,
    wrkw, wrkh, curx, cury, curw, curh, w_handle,
    char_w, char_h, box_w, box_h;

int msg_buf[8];
char *title = "C-MANSHIP #17";
char *text[] = {
    "This is some sample text",
    "for use in the C-manship",
    "window demonstration found",
    "in ST-Log, Issue 17."
};
int num_lines = 4;

main ()
{
    appl_init (); /* Initialize application.
    open_vwork (); /* Set up workstation.
    do_wndw (); /* Go do the window stuff.
    v_ciswvk (handle); /* Close virtual workstation.
    appl_exit (); /* Back to the desktop.

open_vwork ()
{
    int i;

```

```

/* Get first rectangle from list */
wind_get ( &rec2.g-x, &rec2.g-y, &rec2.g-w, &rec2.g-h );

/* Loop through entire rectangle list, */
/* Redrawing where necessary. */
while ( rec2.g-w && rec2.g-h ) {
    if ( !intersect ( rec1, &rec2 ) )
        draw ( rec1 );
    wind_get ( msg_buf[3], &rec2.g-x, &rec2.g-y, &rec2.g-w, &rec2.g-h );
}
/* Unlock window after update. */
wind_update ( END_UPDATE );

set_clip ( flag, rec )
{
    int flag;
    GRECT rec;
    int pxy[4];

    /* Convert rectangle to pxy coords. */
    pxy[0] = rec.g-x;
    pxy[1] = rec.g-y;
    pxy[2] = rec.g-x + rec.g-w - 1;
    pxy[3] = rec.g-y + rec.g-h - 1;

    /* Turn clipping on or off. */
    vs_clip ( handle, flag, pxy );
}

open_window()
{
    /* Find the size of the desktop's work area. */
    wind_get ( 0, MF_WORKXVWH, &fullx, &fully, &fullw, &fullh );

    /* Create window in memory. */
    w_handle = wind_create ( PARTS, fullx, fully, fullw, fullh );

    /* Set the window's title. */
    wind_set ( w_handle, MF_NAME, title, 0, 0 );

    /* Draw the window on the screen. */
    graf_growbox ( 10, 10, 10, 10, fullx, fully, fullw, fullh );
    wind_open ( w_handle, fullx, fully, fullw, fullh );
}

close_window()
{
    /* Get current size of window for use in graf_shrinkbox. */
    /* then close and delete the window. */
    wind_get ( w_handle, MF_CURRXYWH, &curx, &cury, &curw, &curh );
    graf_shrinkbox ( 10, 10, 10, 10, curx, cury, curw, curh );
    wind_close ( w_handle );
    wind_delete ( w_handle );
}

```

```

/* Get graphics handle, initialize the GEM arrays and open */
/* a virtual workstation. */
handle = graf_handle ( &char-w, &char-h, &box-w, &box-h );
for ( i=0; i<10; work-in[i]++ = 1 );
v-opnwk ( work-in, &handle, work-out );
}

do_wndw ()
{
    /* Initialize and open our window. */
    open_window();

    /* Change mouse to arrow. */
    graf_mouse ( ARROW, 0L );

    /* Receive event messages until the window closer is clicked. */
    do {
        event_msg ( msg_buf );
        switch ( msg_buf[0] ) { /* msg_buf[0] is message type. */
            case HM_MOVED:
                do_move();
                break;
            case HM_REDRAW:
                do_redraw ( GRECT *) &msg_buf[4] );
                break;
        }
    } while ( msg_buf[0] != HM_CLOSED );

    /* Close and delete the window. */
    close_window();
}

do_move ()
{
    /* Set window at new location. Also disallow any */
    /* window sizes less than our minimum allowable size. */
    if ( msg_buf[6] < MIN_WIDTH )
        msg_buf[6] = MIN_WIDTH;
    if ( msg_buf[7] < MIN_HEIGHT )
        msg_buf[7] = MIN_HEIGHT;
    wind_set ( msg_buf[4], msg_buf[5], msg_buf[6], msg_buf[7] );
}

draw_interior ( clip )
{
    GRECT clip;
    int pxy[4], y, x;

    /* Turn mouse off prior to drawing. */
    graf_mouse ( H_OFF, 0L );

    /* Calculate clip rectangle and turn clipping on. */
    set_clip ( TRUE, clip );

    /* Get coordinates of window's work rectangle. */
    wind_get ( w_handle, MF_WORKXVWH, &wrkx, &wrky, &wrkw, &wrkh );

    vsf_interior ( handle, 1 );
    vsf_color ( handle, WHITE );

    /* Draw the background in the window's work area. */
    pxy[0] = wrkx;
    pxy[1] = wrky;
    pxy[2] = wrkx + wrkw - 1;
    pxy[3] = wrky + wrkh - 1;
    vsf_rectf ( handle, pxy );

    /* Write the text to the window. */
    y = yksg ( box-h, lines, 4 );
    v_gtext ( handle, wrkx+8, y, text[x] );
}

/* Drawing over, so turn the clipping */
/* off and turn the mouse back on. */
set_clip ( FALSE, clip );
graf_mouse ( H_ON, 0L );
}

do_redraw ( rec1 )
{
    GRECT *rec2;

    /* Lock window for update. */
    wind_update ( BEGIN_UPDATE );
}

```

# Clip-Art Contest WINNERS

**FIRST PRIZE — \$1000 and 3 software packages**

SYLVIA M. HANNA  
Victoria, British Columbia

**SECOND PRIZE — Supra 10-meg hard drive and 3 software packages**

MARYANN E. RAEDER  
Sparks, Nevada

**THIRD PRIZE — Double-sided drive or monochrome monitor and 3 software packages**

LARRY ADLON  
Bramalea, Ontario

**RUNNERS UP — 1-year ANALOG/ST-Log disk subscription and 1 software package each**

SUSAN F. PORUBCAN  
Whitewater, Wisconsin  
ROBERT POWERS  
Annandale, Virginia  
MAURICE MOLYNEAUX  
Hawthorne, Nevada



Next month, a look at the winning entries.

# Make Your Own Magic.

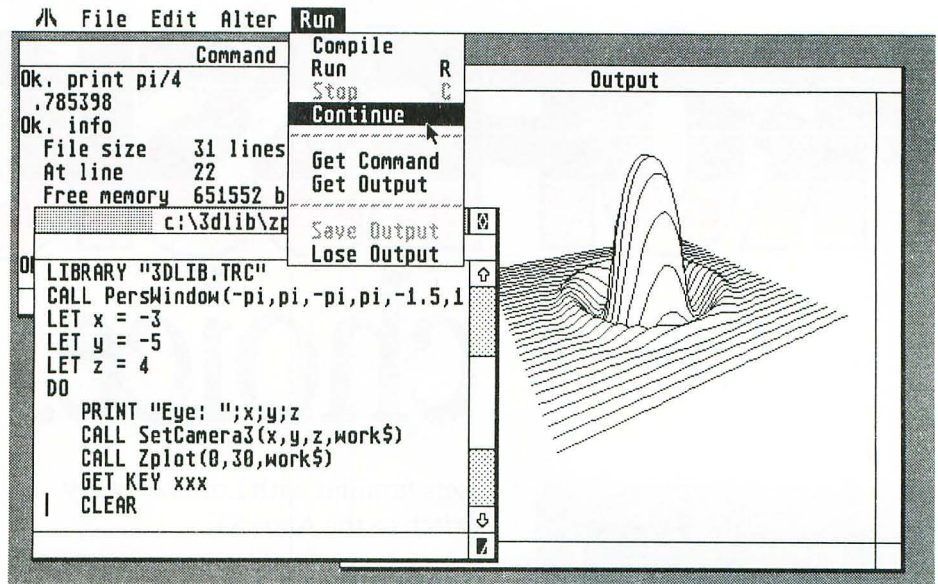

Speed, great graphics and a little bit of magic: that's what you expect from your Atari® ST. And that's what you get from programming in True BASIC.

It's a structured language that's easy to use. A compiler, editor and debugging tools rolled into one. It's the latest from Kemeny and Kurtz, the inventors of BASIC.

If you crunch numbers, you'll appreciate floating-point math that's very fast. Support for large, dynamic arrays, and built-in syntax for matrix algebra.

And True BASIC makes graphics easy. Define your own coordinate schemes and color palettes. Plot entire arrays with a single statement. Apply built-in 2D transforms. Or use the 3D Graphics Library to put some depth in the picture.

You can change line styles, add pull-down menus and get at all the GEM and AES routines. But if portable code is important, there's True BASIC for the PC, Macintosh™ and Amiga® as well.

True BASIC lets you build your own libraries. They can be separately compiled, in BASIC, C or assembly. Debug with breakpoints and immediate mode. Visually trace program execution. Create macros and script files to complement True BASIC's fantastic mouse-based editor.

But if you're just learning, True BASIC will coach you with on-line HELP and friendly error messages. If you need more, we have textbooks and videotapes.

Find out why thousands of engineers, developers, and students use True BASIC to make a little magic. Visit your Atari ST dealer, or call us today at 1-800-TRBASIC.

## Now Shipping!

Language System	\$ 79.95*
Runtime	79.95*
Both	149.95
Libraries	49.95 each

\* Special introductory price

Amiga is a registered trademark of Commodore-Amiga — Macintosh is licensed to Apple Computer — Atari is a registered trademark of Atari Corp. — True BASIC is a trademark of True BASIC, Inc.

### LANGUAGE

- multi-line, user-defined functions
- local, global variables
- SELECT CASE, DO/LOOP
- recursion, modules
- GKS graphics, 2D transforms
- access to GEM, AES features

### COMPILER

- compiles to fast, compact b-code
- parameter type-checking
- optional LET statement
- optional declared variable names
- Runtime package creates stand-alone file

### LIMITS

- strings, program lines to 1 megabyte each
- floating-point 5e-309 to 1.8e+308
- 14-digit floating-point accuracy
- unlimited program size, data space
- variable names up to 31 characters

### EDITOR

- full-screen, mouse-based editor
- global search, replace
- block copy, move, delete
- menu, function key, command line interfaces
- keyboard macros, script files

### DEBUGGING

- set breakpoints and continue
- immediate mode execution
- visual trace, single-step execution
- cross-reference utility

*True*  
**BASIC**™ inc.

39 South Main Street  
Hanover, NH 03755  
(603) 643-3882

# Make the PROFESSIONAL™ choice.

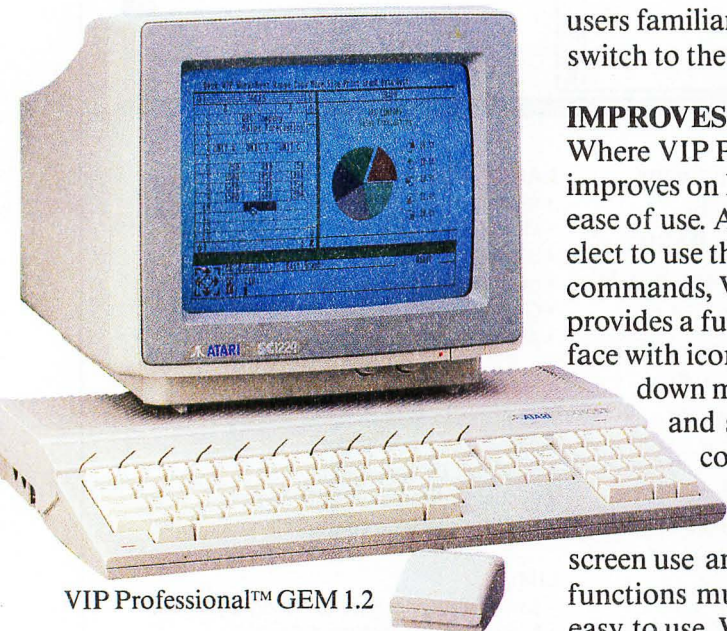

VIP Professional™ GEM 1.2

## VIP Professional™ GEM 1.2, the new generation spreadsheet

Spreadsheet, Database, Graphics and  
Macros With Total Lotus® 1-2-3®  
Functionality.

### A total Solution

#### LOTUS COMMANDS

VIP Professional™ uses commands  
identical to Lotus 1-2-3 allowing

VIP Professional™ is a trademark of DITEK INT'L; Atari  
and ST are trademarks of Atari Corp.; GEM is a trademark  
of Digital Research Inc.; Lotus and 1-2-3 are trademarks of  
Lotus Development Corp.

users familiar with Lotus to easily  
switch to the Atari ST.

#### IMPROVES 1-2-3

Where VIP Professional™ really  
improves on Lotus is its attention to  
ease of use. Although the user may  
elect to use the keyboard for all  
commands, VIP Professional™ also  
provides a full-featured mouse inter-  
face with icons, dialog boxes, pull-  
down menus, mouse ranging  
and scroll bars. This makes  
command selection,  
movement in the sheet,  
range selection, split-  
screen use and a score of other  
functions much more intuitive and  
easy to use. What were once complex  
commands with Lotus are now a  
mouse-click away.

## Atari™ ST™ Special Features

GEM interface with pull-down  
menus, icons, dialog boxes, ranging,  
scroll bars, column grabber, etc.  
Sparse matrix for conserving  
memory. Works with 520ST, 1040ST  
and beyond. Ultra-fast floating point  
math. Compatible with printers  
supported by GEM. Saves graphs  
compatible with Degas™ and Neo  
Chrome™. Totally supports hard drive.  
Works with color or monochrome  
monitors. Multiple windows for  
viewing graphs and worksheet at the  
same time.

Enhanced Text Version 1-2 now available.

Professional available for:

**APPLE® IIgs**  
**APPLE® IIe/c**  
**ATARI ST™**  
**AMIGA™**  
**XENIX®/UNIX®**

#### FLEXIBILITY

VIP Professional™ gives the user, no  
matter the computer, a uniform,  
powerful program that conforms to  
the Lotus standard and which can  
exchange data with any other  
program using the 1-2-3 file format.  
VIP Professional™ is available for  
the Atari ST, Apple IIe, IIc, IIgs and  
Commodore Amiga.

Available at your local Atari dealer.



CIRCLE #132 ON READER SERVICE CARD



## QMS-PS 800+ PostScript Laser Printer

QMS, INC.  
P.O. Box 81250  
Mobile, AL 36689  
\$5945.00

by Charles Bachand

For the sake of argument, let's say that your business needs an Apple LaserWriter, a Diablo 630 daisy-wheel printer, a Hewlett-Packard LaserJet Plus and a Hewlett-Packard 7475 Plotter.

How much would you be willing to pay for all this? Before you answer, let me give you a few prices. LaserWriters currently list for \$5999.00, while a LaserJet Plus will take an additional \$3995.00 out of your wallet. That's ten grand—and you haven't even picked up the plotter or the daisy-wheel yet.

Now, what if I told you that you could get all these printers wrapped up in one package? You don't believe me? Do I look like the type who'd sell you a few parcels of swamp land? No, of course not, and besides, I just happen to have the proof sitting on my desk now: a brand spanking new **QMS-PS 800+** laser printer. I've been having a lot of fun with this puppy (although this printer is definitely not a *dog!*) and I've only started to scratch the surface of its capabilities.

The **QMS-PS 800+** is, first and foremost, an extremely fast (8 pages per minute) laser printer that implements the latest release of the PostScript programming language. It can print text and do screen dumps, as well as execute PostScript programs to draw lines, curves, figures and text—in any size or any orientation, in black-and-white or any number of shades of gray—through its built-in PostScript

commands. This is, I feel, a truly amazing machine.

To accomplish all this magic, the **QMS-PS 800+** incorporates the same processor in its design that's found in the ST itself—the powerful 68000. This chip has access to 2 megs of internal RAM (shades of the Mega ST) and 1 megabyte of ROM. A little over half of the available RAM is used to store the display image, with a resolution of 300 dots per inch, both vertically and horizontally. You can produce pretty detailed images with 90,000 dots per square inch.

The 1 megabyte of ROM holds the PostScript language and thirty-five scaleable character fonts, the Diablo 630, Hewlett-Packard Laser Plus and 7475 Plotter emulators. I've used the **QMS-PS 800+** in all modes except the one for the 7475 Plotter (I don't have any graphic software that can talk to a plotter), and they all work well. Any minor differences in operation between the **QMS-PS 800+** and the printer or plotter that it's emulating (such as the internal 7475 Plotter software not being able to handle multi-colored pens simply because a laser printer is a black/white-only device) is documented in the manual that comes with the unit.

The lack of Epson emulation on the machine has caused me to start rewriting several print utilities (we currently use a QMS Kiss in Epson mode for magazine listings), and I sadly miss the ability to do an ALT/HELP from my ST to generate a screen dump.

The **QMS-PS 800+** comes only with serial I/O connectors (a 9-pin for use with the AppleTalk network, and a 25-pin to communicate with the rest of the world). The standard baud rates of 1200 and 9600 are switch selectable, but other rates can easily be implemented under software control.

A parallel printer port would have been a nice addition here, but parallel ports usually only handle data going one way. The PostScript language sends error messages and other bits of information back to the computer as strings of text, hence the need of a two-way data path via a serial port.

The printer remembers these settings (as well as other parameters like parity, number of pages printed, whether or not to print a test page on power-up, etc.) by storing them in an EEROM (Electrically Erasable Read Only Memory). An EEROM can be programmed about 10,000 times before it finally wears out. This gives it a lifetime of about thirty years—assuming that the EEROM chip gets programmed only once per day in that time period.

My one other complaint has to do with documentation: one of the reasons to get a machine like this—one that emulates a number of different printers—is so you won't be needing a roomful of different printers. If a particular piece of software wants to talk to a Diablo and another wants to talk to a Hewlett-Packard LaserJet Plus, all you need do is flip a switch to, essentially, have an entirely new out-



**SCHEDULE E**  
(Form 1040)  
Department of the Treasury  
Internal Revenue Service

**Supplemental Income Schedule**  
(From pensions and annuities, rents and royalties, partnerships, estates and trusts, etc.)  
▶ Attach to Form 1040 ▶ See Instructions for Schedule E (Form 1040).

**1979**

Name(s) as shown on Form 1040 \_\_\_\_\_ Your social security number \_\_\_\_\_

**Part I Pension and Annuity Income.** If fully taxable, do not complete this part. Enter amount on Form 1040, line 17.  
For one pension or annuity not fully taxable, complete this part. If you have more than one pension or annuity that is not fully taxable, attach a separate sheet listing each one with the appropriate data and enter combined total of taxable parts on line 4.

1a Did you and your employer contribute to the pension or annuity?  Yes  No  
b If "yes," do you expect to get back your contribution within 3 years of the date you receive the first payment?  Yes  No  
c If "yes," show: Your contribution  1 of Contribution received in prior years  2

2 Amount received this year \_\_\_\_\_  
3 Amount on line 2 that is not taxable \_\_\_\_\_  
4 Taxable part (subtract line 3 from line 2). Enter here and include in line 18 below \_\_\_\_\_

**Part II Rent and Royalty Income or Losses.** If you need more space, attach a separate sheet.

5a Have you claimed expenses connected with your vacation home (or other dwelling unit) rented to others (see instructions)?  Yes  No  
b If "yes," did you or a member of your family occupy the vacation home (or other dwelling unit) for more than 14 days during the tax year?  Yes  No  
c Did you elect to claim amortization (under section 181) or depreciation (under section 167(o)) for a rehabilitated certified historic structure (see instructions)?  Yes  No  
d Amortizable basis (see instructions) \_\_\_\_\_

(a) Property code (insert in Part V)	(b) Total amount of rents	(c) Total amount of royalties	(d) Depreciation (explain in Part VI) or expenses (attach computation)	(e) Other expenses (explain in Part VI)	(f) Loss	(g) Income
Property A						
Property B						
Property C						
Property D						
Property E						
7 Amounts from Form 4853...						
8 Totals...						
9 Total rent and royalty income or (loss). Combine amounts in columns (f) and (g), line 8. Enter here and include in line 18 below						

**Part III Income or Losses from —**

(a) Name	(b) Employer identification number	(c) Loss	(d) Income
Partnerships			
Estates or Trusts			
Small Business Corporations			

10 Add amounts in columns (c) and (d) and enter here \_\_\_\_\_  
11 Combine amounts in column (c) and (d), line 10, and enter net income or (loss) \_\_\_\_\_  
12 Additional first-year depreciation \_\_\_\_\_  
13 Total Partnership Income or (loss). Combine lines 11 and 12. Enter here and include in line 18 below \_\_\_\_\_

14 Add amounts in columns (c) and (d) and enter here \_\_\_\_\_  
15 Total estate or trust income or (loss). Combine amounts in columns (c) and (d), line 14. Enter here and include in line 18 below \_\_\_\_\_

16 Add amount in columns (c) and (d) and enter here \_\_\_\_\_  
17 Total small business corporation income or (loss). Combine amounts in columns (c) and (d), line 16. Enter here and include in line 18 below \_\_\_\_\_

**Part IV**  
18 **TOTAL** income or (loss). Combine lines 4, 9, 13, 15, and 17. Enter here and on Form 1040, line 18. \_\_\_\_\_

19 Enter your share of gross farming and fishing income applicable to Parts II and III. \_\_\_\_\_

don't have to get your hands dirty programming in a new language. Publishing Partner from SoftLogik is like this. It incorporates a PostScript printer driver that will produce documents of unbelievable quality. To accomplish this, Publishing Partner interprets the contents of the page and generates a PostScript program that is then sent to the printer. This is great for most of your typesetting work, but for those who want something really special—and who have the time to sit down and learn PostScript—there is literally no limit to what can be accomplished. The examples of presentation-type graphics shown here were all done on the QMS-PS 800+

The QMS-PS 800+ is faster than the Apple LaserWriter it replaces, and it's cheaper, too. The speed is mainly due to the extra memory space available to it (2 megabytes as opposed to 1 megabyte on the LaserWriter) and the latest rendition (Version 46.1) of the PostScript language, which makes superb use of the extra memory.

And now, bear with me for a little bit of information about the language itself. PostScript is a FORTH-like language, in that it implements an operator stack in a fashion similar to the Hewlett-Packard pocket calculators that use RPN (Reverse Polish Notation). The operands must be pushed onto the stack before the operations can be executed. For example, to add 2 and 3 on an algebraic calculator—the type that has an "equals" key—you punch

put device. Great! But if you want to start from scratch and write your own LaserJet Plus driver, you run into a problem. What commands, parameters, etc., does a LaserJet support? The QMS documentation leaves you with this line from their manual, "For information about these commands, refer to the LaserJet Plus documentation." Gee, I was under the impression that I had bought this thing so that I wouldn't have to buy a LaserJet. Looks like it's time to call Hewlett-Packard and see if they'd like to sell me a manual or two (the 7475 Plotter docs say the same thing).

On the brighter side, their PostScript documentation is excellent. QMS was thoughtful enough to have included the two manuals written by Adobe Systems incorporated—to get you started. These books are an outstanding value in both cost (they come free with your printer) and in the wealth of information present-

ed. The first book, "PostScript Language Tutorial and Cookbook," gets you started in using the language. It makes intensive use of programming examples as it walks you through interesting graphics and text applications, always building on what has gone before. The other book, the "Language Reference Manual," documents all of PostScript's built-in commands. If you anticipate acquiring a PostScript-compatible printer in the future, I heartily recommend these two books. Some ST application programs present PostScript output directly to the printer, so that you

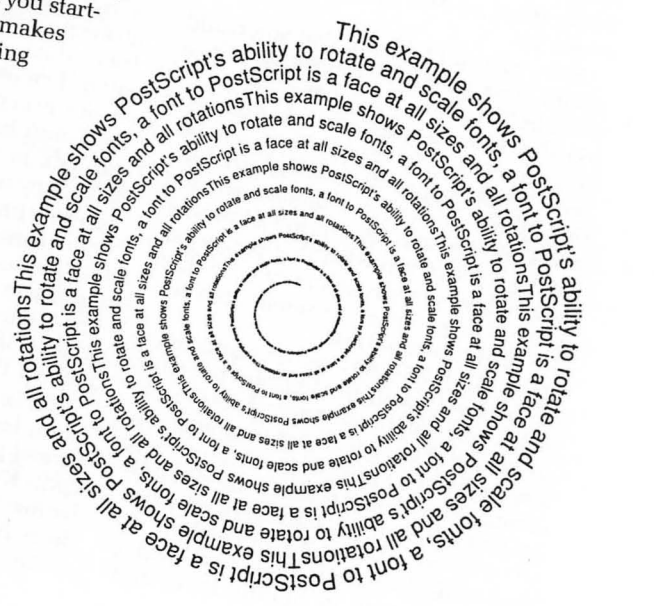

in the sequence 2+3=, and the number 5 appears. On an RPN calculator, you would type the sequence 2 ENTER 3 + to get 5. The ENTER key is used to tell the calculator when one number ends and another begins.

Since programs written in PostScript are standard text files, we can use the SPACE key to separate different values. And, since PostScript uses the word *add* instead of a plus sign to signify addition, our example in PostScript would look like this: 2 3 *add*. This leaves the value of 5 on the stack, all ready for the next operator to use.

What goes into a PostScript printer is usually *not* what comes out of it. A short example is probably in order. The following program will draw a square that measures one inch on each side. This square will be positioned one inch up and to the right of the bottom left-hand corner. We then print the text *Demo Box* above it, using the Helvetica font in 18-point size. Oh, I almost forgot: the standard unit of measure in PostScript is the point, and there are 72 points to an inch. Also, any text that follows a percent sign (%) is considered a comment by the PostScript software; it will not be executed. Here's what you'll need:

```

XXXXXXXXXXXXXXXXXXXX Demo PostScript Program
72 72 moveto % move current point up and over one inch
0 72 rlineto % draw relative line left one inch
72 0 rlineto % draw relative line up one inch
0 -72 rlineto % draw relative line right one inch
closepath % draw back to the origin set in moveto
stroke % draw the box into RAM area
/Helvetica % push font name onto stack
findfont % replace name with font directory
18 scalefont % scale the font to 18 point size
setfont % make it the current font
72 146 moveto % move current point to just above box
(Demo Box) % push text "Demo Box" onto the stack
show % draw text in current font into RAM
showpage % print everything on paper and eject page

```

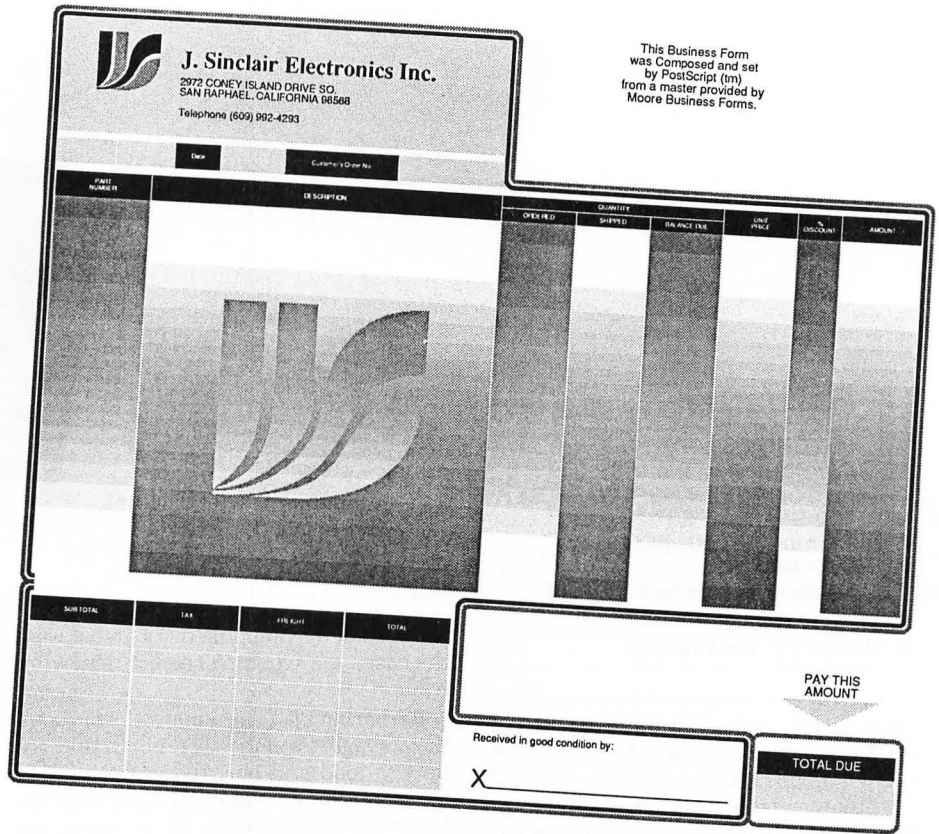

I usually write PostScript programs in the capture buffer within the terminal program Flash. As I add new sections of code, I like to get test printouts of the work in progress (in order to see just how badly I've messed things up). To do this, I merely upload the capture buffer to the printer, wait a few seconds for the QMS-PS 800+ to do its stuff and presto—instant gratification!

All in all, I'm extremely happy with the QMS-PS 800+ printer. It has done everything that I've told it to do, and if I won the Lottery tomorrow, I'd probably go out and buy one for my very own. But at a price of nearly six grand, it certainly won't be the printer for everyone. //

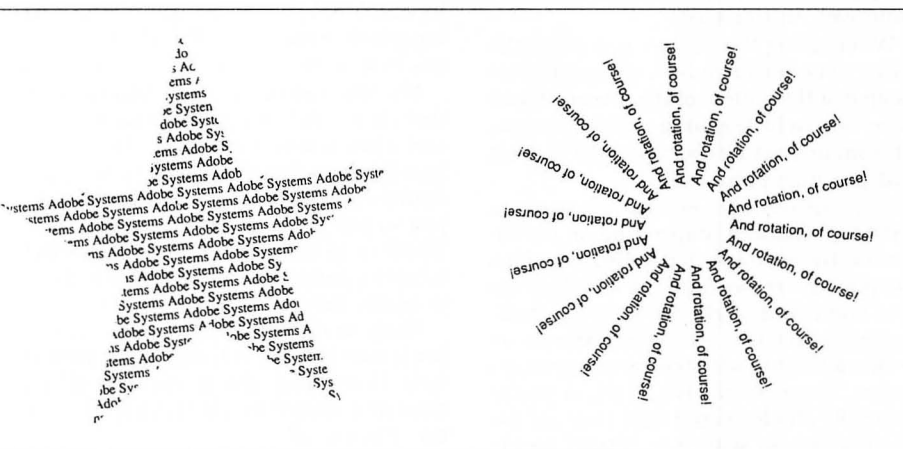

## Barbarian

PSYGNOSIS LTD.  
Distributed in the U.S.  
by COMPUTER SOFTWARE SERVICE  
129 Sherman St.  
Cambridge, MA 02140  
800-343-7535  
Medium resolution \$39.95

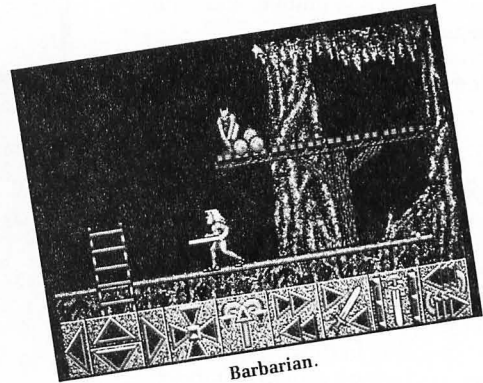

Barbarian.

by Michael J. DesChenes

I think it was because of the name *Psygnosis* on the packaging that I decided I wanted to bring this game home. One of the first games I really enjoyed on the ST was another from this Liverpool-based software company, also an action/adventure, called *Brataccas*. I wasn't disappointed by *Barbarian*. I'm the type of guy who gets bored too easily with the text-type adventures. But give me good graphics, sound effects and a character I can see on the screen, and I'll be up till the wee hours of the morning trying to complete my assigned task. A game must also take less than two weeks to complete, or I'll end up turning my attention to something else and never get a chance to finish it. You try to go back to a game you got halfway through a month earlier, and see how tough it is to get started again.

Okay, so I'm easily bored and have a short attention span. But I know what I like, and *Barbarian* fits my requirements to a tee: great graphics, effective digitized sound and playability that keeps you coming back for more. (And I bet you thought you'd have to read the last sentence to find out if I liked the game.)

In *Barbarian*, you control the hero Heger, the most famous dragonslayer of them all. The program uses two disks. The first contains most of the character and game-playing information, while the second has the various screen set-ups. Don't worry, though; you only have to put each disk in once to play the game. You're

not constantly swapping disks. If that were the case, you wouldn't see me reviewing it here.

*Barbarian* also has a manual/storybook that I suggest you read—if not to find out how to load and play the game, then to get a few clues to help you along the way. It's only about a dozen or so pages, not that bad. The most important portion of the documentation is the one-page playing instruction sheet. For the most part, I kept this piece of paper in front of me while playing. It shows what keys/icons do what, and can come in handy.

The instructions say that you can use the mouse, keyboard or joystick with *Barbarian*, but they don't recommend using a joystick. I can see why: I couldn't get most of the functions to work with the joystick. I'll normally choose a joystick over the mouse, but the mouse works quite well in this case.

When using the mouse, you place the arrow over one of sixteen different icons located at the bottom of the screen. These icons need a little getting used to; I guessed from inspecting them that the English still use hieroglyphics.

Some of the icon commands perform different functions, depending on the situation. For example, depending on which weapon you're holding, the attack or defend command works differently. Attacking with the bow obviously shoots an arrow; attacking with the sword generates lunges, chops or thrusts. And, if you're using the shield, you'll find yourself deflecting attacks with it or hitting an ob-

ject or person. Don't think that you start with all these weapons at your disposal. The only items you have at the beginning of your adventure are your sword and your loincloth. The bow, arrows and shield must be picked up along the way—not an easy task.

In order to finish the game (your quest), you must locate and destroy the crystal which is the source of the evil power of Necron, your half brother. You'll have to read the book to find out the whole story.

Once the crystal has been destroyed, the volcano in which Durgan (the underground world) is located will start to erupt, making it imperative that you reach the surface again before it blows. And I thought it was tough getting to Necron in the first place!

The time it takes to destroy the crystal is not only the score, but is also the time in which you have to get back to the starting point of the game. So I'd advise you not to rush to destroy the crystal.

My only complaint with *Barbarian* is that there's no save game feature. So, if and when you've used up the last of your four lives, you have to start all over again. And it can take you up to twenty minutes just to get to the point where you died. There were times when I got so frustrated at the game that I swore never to touch it again, but I did.

Okay, so I like it. I've destroyed Necron, but it sure is tough getting back to the surface. How about giving me back all my lives as a reward for destroying the crystal? Please? //

# GTS-100 FOR THE ATARI ST COMPUTERS.



Photo: BRADLEY GRAPHIC DESIGN (818) 994-5451

## NOTHING DRIVES AN ATARI ST LIKE A GTS-100

- The GTS-100 is designed for compactness, reliability and improved performance.
- The front panel displays, track read-outs. Optimizing your concentration. Eliminating doubt and second guessing.
- The *Busy* LED tells you that your Atari ST and the GTS are trying to read or write information on your diskette.
- Built-in, low friction metal band GTS *cruise control* head positioning assures trouble-free performance.
- The auto shutter opens upon insertion of the diskette and closes when it is removed, protecting the disk drive and media from external contamination.
- The GTS is a dual sided, double density floppy disk drive with a 720K formatted storage capacity.
- The GTS is sleek and perfectly proportioned. Eye catching. Distinctively European Gran styled.
- You'll love the way it parks next to your Atari.  
Easily. Comfortably. Handsomely.

Future Systems, Inc.  
21634 Lassen Street  
Chatsworth, Calif. 91311  
Tel: (818) 407-1647

The drive will be  
well worth it.

The incredible 3½ GTS-100 Disk Drive.



**QUIET**

**COMPACT**

**RELIABLE**

CIRCLE #135 ON READER SERVICE CARD

# INDEX TO ADVERTISERS

READER SERVICE #	ADVERTISER	PAGE #	READER SERVICE #	ADVERTISER	PAGE #
125	Abacus	30	122	Megamax, Inc.	20
127	Alpha Systems	47	103	Microware Systems Corp.	5
—	ANALOG Publishing	20	113	Navarone Industries, Inc.	14
128	Beckemeyer Development Tools	66	119	New World Software	16
124	Compucat	28	131	Newell Industries	159
126	Computability	39	101	Omnitrend	IFC
129	Computer Creations, Inc.	48	136	Proco Products	184
110	Computer Fenestrations	14	130	Prospero	53
133	Dr. T's Music Software	65	102	Regent Software	2
115	Ergotron, Inc.	14	112	Scanam	72
108	Firebird Licences, Inc.	14	104	SoftLogik Corp.	7
121	Font Factory	19	—	Sophos Chess	69
135	Future Systems Software	83	138	Spectrum Holobyte, Inc.	IBC
123	Graphic Creations	28	120	TDC	19
114	H&H Enterprises	14	137	Tech Specialties	84
139	Hybrid Arts	OBC	109	Three-Sixty	14
106	Iliad Software	12	134	True BASIC, Inc.	77
111	Interactive MicroSystems	14			
132	ISD Marketing	60,78			

This index is an additional service. While every effort is made to provide a complete and accurate listing, the publisher cannot be responsible for inadvertent errors.

## ProCopy <sup>ST</sup> BACKUP UTILITY

You can't backup your software because copy protection locks you out. **ProCopy** is the key!

- Protects against the accidental loss of expensive software
- Works with all Atari STs
- Copies both S/S & D/S disks
- Use with 1 or 2 disk drives
- Not copy protected
- **FREE** shipping and handling
- **TOLL-FREE** telephone number
- Updates are only \$12 with return
- Orders shipped same day
- Disk analyze function included

Dealer Inquiries Welcome

Call (800) 843-1223 **\$34.95**

Send check for \$34.95 (overseas add \$2.00 for air mail) to:

**PROCO PRODUCTS**

P.O. BOX 665, CHEPACHET, RHODE ISLAND 02814 USA  
(401) 568-8459

Available Internationally in Europe and Australasia

THE MOVING FINGER CO.  
Building 2  
Shamrock Quay  
Southampton, SO1-1QL  
England  
Tel. 0703-227274

TECH-SOFT  
COMPUTER WHOLESALE  
324 Stirling Highway  
Claremont  
Western Australia 6010  
Tel. 09-385-1885

CIRCLE #109 ON READER SERVICE CARD

## Memory Upgrades for Atari ST Computers 520ST, 1040ST, and 520STfm Up to 4 MB on ONE board with NO SOLDERING!!!

Expand your ST's memory to One MB, 2.5 MB or even 4 MB internally with the tech-specialties plug-in memory modules. All boards use 256k chips for upgrades to 1 MB, and 1 Mbit chips for 2.5 and 4 MB upgrades. User-upgradable boards are FULLY socketed, even 1040ST and 520STfm! Economy board for 520ST w/soldered chips (not upgradable) is also available. ALL boards are plugged in with NO SOLDERING, fit under the shielding and use the standard power supply. The 68000 CPU remains fully accessible for later enhancements like the "Blitter." Clock options are available either

on-board (\$30) or separate (\$38) with software.

NOW AVAILABLE! The first expandable hard disk for the ST! tech-specialties now offers a 10 MB hard drive system, complete with drive, case, power supply interface and cables, PLUS room and internal connections for a SECOND half-height hard disk! All for less than \$400.00!

... And only from tech-specialties!

Chip prices may vary slightly with market conditions. Please call for current prices!

520A: socketed, no ram	\$ 129.00	1040A: 16 sockets, no ram	\$110.00
520B: 1MB, w/sockets	\$ 179.00	1040B: 32 sockets, no ram	\$149.00
520C: 2.5 MB, w/sockets	\$495.00	1040C: 2.5 MB w/sockets	\$495.00
520D: 4 MB--the max	\$845.00	1040D: 4 MB--the max	\$845.00
520-1: 1 MB soldered	\$ 129.00	10 MB expndble hard disk	\$395.00
Zero-height socket kit	\$ 30.00	Hard disk kit, less drive	\$295.00

tech-specialties co.

909 Hodgkins, Ste. A, Houston, Tx 77032  
phone: (713) 590-3738

CIRCLE #137 ON READER SERVICE CARD

# DESKTOP PUBLISHING ON THE ATARI ST

Now there's a real alternative 68000-based desktop publishing system!

Fleet Street Publisher provides all the features you would expect of a high-priced system but at a price you can afford.

The program runs under GEM, so it's friendly and very easy to use. Working on a what-you-see-is-what-you-get principle, designing good page layouts becomes almost intuitive, with true-to-scale fonts and images displayed on the screen.

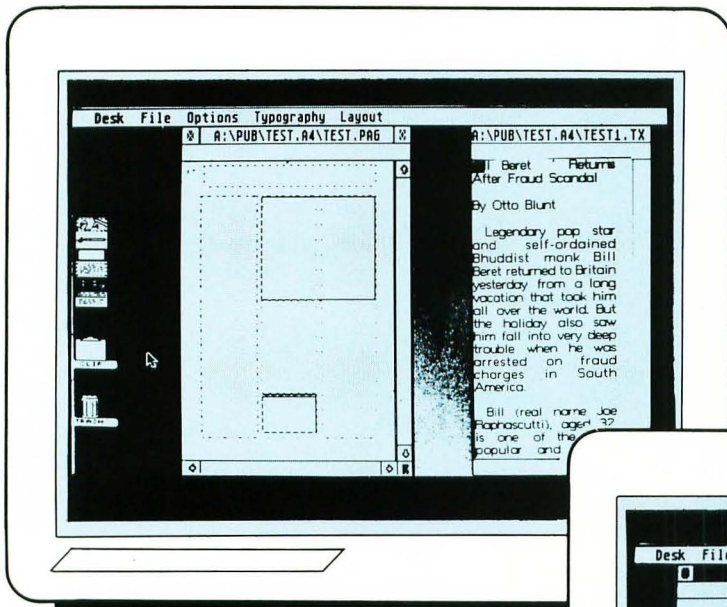

## Use it to create

- Multi-column newsletters and publications
- Advertising layouts and brochures
- Business reports and contracts
- Promotional literature and specification sheets
- Flyers and overhead transparencies
- Organization charts and flow charts
- Invitations and announcements
- Menus, cards, letterheads and much more

## Special features

- Point sizes from 4 to 72 (up to 216 on a 1040)
- Over 150 ready-made graphics images supplied on disk
- Up to 7 windows open at any one time
- International characters included
- User controllable letters, word and line spacing
- 14 levels of shading for boxes
- Edit text in one window and feed straight into the page in a second window
- Includes art conversion program to convert other ST graphics files



## Systems Requirements

- Atari 520 ST minimum
- Epson and compatible dot matrix printers
- Monochrome OR color monitor
- Laser printers including Postscript and Hewlett Packard Laser Jet

Fleet Street Publisher is available from your local dealer



## Spectrum HoloByte

2061 Challenger Drive  
Alameda, CA 94501  
(415) 552-3584

~~Kill~~  
~~Put on a~~ Happy Face!



# MIDI MAZE

**New from Xanth F/X! The game that lets up to 16 people play at the same time on 16 different STs. All networked together using MIDI.**

Design your own mazes using First Word™.  
Select up to 15 happy face opponents in single player mode.  
Requires 1 MIDI cable for each computer in network.

Only \$39.95 suggested retail.

For a free product catalog and newsletter call or write us at:

 **Hybrid Arts, Inc.™**

11920 W. Olympic Blvd., Los Angeles, CA. 90064

**Computer BBS:** (213) 826-4288 **Main Office:** (213) 826-3777 **Telex:** 4931231 (HYBRDUI)

Hybrid Arts offers a full range of MIDI products for the Atari ST including:

**EZ-Track™:** A 20 track polyphonic MIDI recorder.

**EZ-Score™:** A sheet music printing program.

**CZ-Android™:** A patch librarian-editing system for the Casio CZ keyboard series.

**DX-Android™:** A patch librarian-editing system for the Yamaha DX-7 and TX series.

**GenPatch ST™:** A generic patch librarian system for all MIDI devices.

**MIDITrack ST™:** A professional MIDI recorder available with and without SMPTE sync.

**ADAP SoundRack™:** A 16 bit digital audio workstation for music and broadcast professionals.

Atari ST is a trademark of Atari Corp.; DX-7 is a trademark of Yamaha International Inc.; CZ and Casio are trademarks of Casio Inc.; MIDI-MAZE, EZ-Track, EZ-Score, GenPatch ST, MIDITrack ST, ADAP SoundRack and Hybrid Arts are trademarks of Hybrid Arts Inc.; DX-Android and CZ-Android are trademarks of Hybrid Arts Inc. and are not affiliated in any way with LUCASFILM LTD.

CIRCLE #139 ON READER SERVICE CARD