

\$2.25

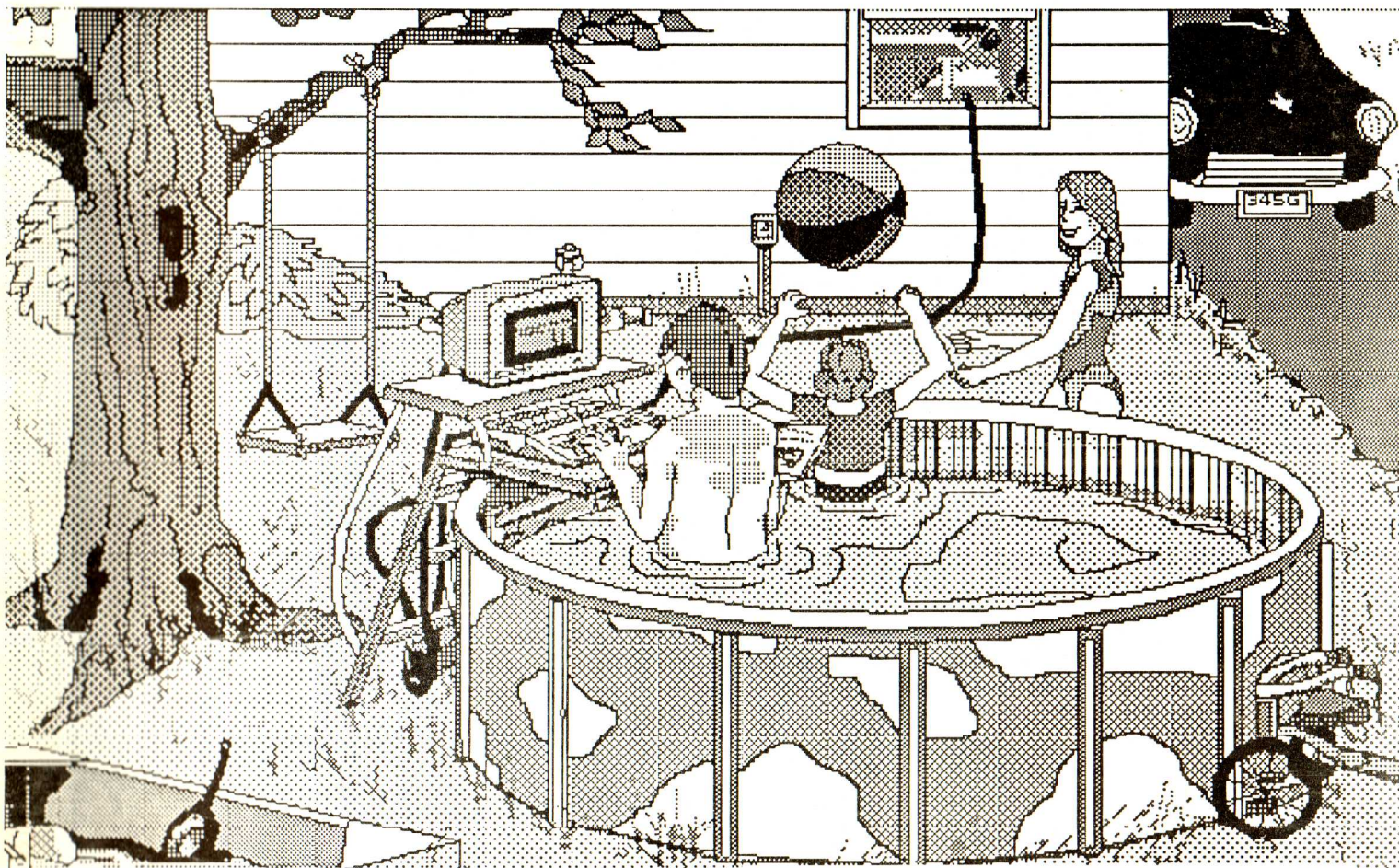

### Computers & Education

The use of computers in the classroom is discussed by G.L. Ray (TACE)

### MultiScan Monitor for the ST

Leroy Valley (TAG) shares his experience with Void Productions' monitor and interface combo that can display all ST resolutions

### DeskTop Publishing on a 130XE

G.L. Ray (TACE) gives us a look at using an 8bit Atari to produce a school newspaper

### The GRASS Calculator

An excellent on-screen calculator for the 8bit Atari. Atari BASIC type-in program from the Grand Rapids Atari System Supporters

### I Love a Mystery

A bit of deductive reasoning from Gordon Totty (MACE), who discusses tracking down the cause of his ST hardware woes

**AND MORE...**



**1st STOP**  
Computer Systems Ltd  
7085 Corporate Way  
Dayton, OH 45459

**Toll-free Order Line 800-252-2787**  
**Tech/Info Line 513-438-0551**

If you don't see it listed, ask!  
Same day shipment on most items  
We specialize in the Atari ST line  
No extra charge for credit cards

**HOURS:**  
**Mon-Fri 9 am - 9 pm EST**  
**Sat 10 am - 6 pm EST**

### ST Games

Captain Blood	32.95
Carrier Command	32.95
Dive Bomber	25.95
Dungeon Master	25.95
DM II - Chaos Strikes Back	18.95
Elite	23.95
FALCON	28.95
F15 Strike Eagle	25.95
Gauntlet II	29.95
Gunship	29.95
Heroes of the Lance	27.95
Jet	35.95
Kings Quest I, II, III, IV, V	call
Leader Board Duel Pak	16.95
Leatherneck	26.95
Missile Command	18.95
Obliterator	26.95
OutRun	22.95
Shadowgate	33.95
StarGlider 2	27.95
Test Drive	26.95
Typhoon Thompson	22.95
Universal Military Simulator	32.95

EUROPEAN TITLES..... call

### JOYSTICKS

Atari Standard	6.95
Epyx 500XJ	18.95
Wico Bat Handle	21.95

### DISKS

FUJ (10)	14.95
Maxell (10)	16.95
Sony (10)	16.95

We certainly don't have room to list everything here, so if you don't see what you want listed, call anyway. You'll be glad you did.

We are Atari people from 'way back' and we will do our best to keep you, our customers, satisfied. Thank you for your business.

Bruce, Steve, Bob, and 'the Crew' of **1st STOP**

### ST Productivity and Applications

CAD 3D (ver 2)	64.95
DataManager ST	48.95
dBMAN 5.0	153.95
DEGAS Elite	38.95
Desk Cart	68.95
TimeWorks Publisher ST	79.95
Easy Draw /Supercharger	98.95
Flash 1.6	22.95
FONTZ!	22.95
G + Plus	22.95
GFA Draft Plus	88.95
Mavis Beacon Typing	32.95
MIDI Recording Studio	26.95

**WE BUY AND SELL USED ATARI HARDWARE AND SOFTWARE**

MultiDesk	19.95
NeoDesk 2	34.95
PC - Ditto (IBM Emulator)	64.95
PrintMaster Plus	25.95
ProCopy	27.95
Spectrum 512	48.95
ST Talk Professional	19.95
Thunder!	27.95
Turbo ST	35.95
UltraScript	call

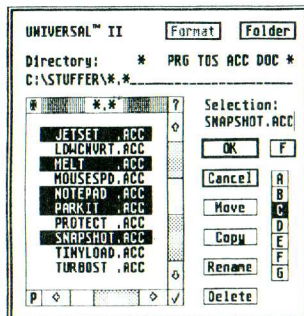

**Universal Item Selector II**  
**\$13.95**

### LANGUAGES

Personal Pascal	65.95
HiSoft Basic	54.95
Prospero Pascal	call
Prospero C	98.95
True Basic	51.95
Assempro	38.95
GFA Basic 3.0	55.95
GFA Compiler	call
GFA Basic Book	26.95
GFA Companion	33.95
GFA Quick Ref Manual	11.95
Megamax Laser C	119.95
STAC	49.95
STOS	44.95

### ST Hardware

ST's	call
Cables	call
Color ComputerEyes	179.95
Disks	call
Drive Master	36.95
MIDI Cables	call
Modems	call
Monitor Master	39.95
Mouse Master	33.95
Mouse Mat, Deluxe	8.95
Mouse Mat, Regular	6.95
Panasonic Printers	call
PC-Ditto II	call
Printer Ribbons	call
Spectre 128	149.95
Spectre GCR	call
Surge Suppressors	call
Tweety Board (STereo)	41.95
VideoKey	68.95

### Super Specials for Desktop Publishers

**CALAMUS**  
**\$179.95**

**PageStream**  
**\$119.95**

**Touch-Up**  
**\$119.95**

### SPREADSHEETS

LDW Power	98.95
SwiftCalc	48.95
VIP Professional	99.95
Master Plan	68.95
Analyze!	24.95

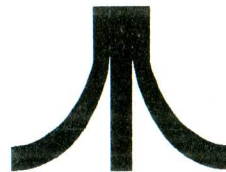

**WE SERVICE ATARI EQUIPMENT**

### WORD PROCESSORS

WordUp (revised)	51.95
WordWriter ST	48.95
First Word Plus	62.95
WordPerfect	185.95

### MODEMS

Avatex 1200E	89.95
Supra 2400	134.95
Zoom 2400 (Best Buy)	128.95



**3.5" DS/DD**  
**Generic Bulk Disks**  
**.89 each with purchase**

### DRIVES

GTS-100	198.95
IB 5.25"	209.95

### PRINTERS

Star NX-1000	189.95
Star NX-1000 Color	249.95
NEC 2200	389.95
Panasonic 1124	359.95
Panasonic 1180	199.95
Panasonic 1191	289.95
Panasonic Laser Printer	1449.95

### HARD DRIVES

Supra 30	649.95
Supra 60	1149.95
ICD	call

### NEW! 1st STOP DRIVE KIT

**3.5" DS/IDD, 84-track Floppy Disk Drive**  
Top-rated Toshiba drive mechanism  
Case matches your ST  
Dust door & flip up stand included  
No additional cables needed - No soldering  
Easy to assemble - Takes less than five minutes!  
Guaranteed 90 days parts and service  
(1 year on drive mech from Toshiba)

ONLY

**\$149.95**



ORDER INFO: No extra charge for credit card - COD \$3.95 - Next day delivery extra - Alaska & Hawaii UPS Blue Label only - APO & FPO - Canadian orders minimum \$5 - Ohio residents add 6% sales tax - Allow 10 business days for personal or company checks - Returns subject to 20% re-stock fee - Defectives require return authorization number to be accepted for repair or replacement - Prices subject to change - call for price and availability - We check all credit card orders for validity.

<b>Atari News and Comment</b> 4	<b>A MultiScan Monitor</b> 19
The latest scoop on what's happening in the Atari world	for the ST Leroy Valley (TAG) shares his experience with Void Productions' monitor/interface that can display ALL ST resolutions
<b>I Love a Mystery</b> 6	<b>GFA Artist</b> 21
A bit of deductive reasoning from Gordon Totty (MACE), who details his ST hardware woes	Donavan Vicha reviews an animation package for the ST
<b>Computers &amp; Education</b> 10	<b>Last Hacks</b> 31
G.L. Ray (TACE) discusses using computers in the classroom	Predictions from Tim Sharpe...if you want answers, why not "Ask NostraTIMus?"
<b>UltraScript</b> 12	
A review of the PostScript emulator from Atari and Inagem, written by Richard Brice	
<b>The GRASS Calculator</b> 14	<b>CACE</b> 25
The Grand Rapids Atari System Supporters present an excellent Calculator program for the Atari 8bit. Atari BASIC type-in source code included	<b>CHAOS</b> 26
	<b>GAG</b> 26
	<b>GKAUG</b> 27
	<b>GLASS</b> 27
	<b>GRASS</b> 27
	<b>MACE</b> 28
	<b>TACE</b> 29
	<b>TAG</b> 29
	<b>WAUG</b> 30
<b>DeskTop Publishing</b> 18	
on a 130XE A look at using an 8bit Atari for creating a school newspaper, by G.L. Ray (TACE)	<b>Stanley &amp; Knob</b> 31
	<b>AIM Advertisers</b> 32
	<b>Events Calendar</b> 32



**GRASS Calculator** 14



**Stanley & Knob** 31

**On the Cover**  
A touch of Summer for all you Atarians out there. Artwork by Steve Volker (TAG).

Managing Editor: Patricia Snyder-Rayl  
Editor: Bill Rayl  
Artwork: Steve Volker, Migraph  
Photography: Bob Retelle

AIM is produced with a 2.5 meg Atari ST, HP LaserJet II, Timeworks' Publisher ST, PageStream, and Migraph's Easy-Draw

Atari Interface Magazine is a monthly magazine that also serves as the official newsletter of several independent Atari user groups and is not affiliated with Atari Corp. in any way. AIM is published by Unicorn Publications, 3487 Braeburn Circle, Ann Arbor, MI 48108. A subscription to AIM is included in membership in any participating club or may be purchased directly from Unicorn Publications. For advertising or user group discount subscription rates, please call (313) 973-8825.

AIM does not knowingly reprint copyrighted material without first obtaining permission from the source. Non-commercial user group publications are granted permission to reprint articles from this magazine as long as credit is given to AIM and the author (and club if applicable). Opinions expressed within articles in AIM are solely the views and responsibility of the authors and do not necessarily represent the opinions of AIM or of any participating group. Atari, the Fuji symbol and names of various Atari computer products are trademarks of Atari Corp.

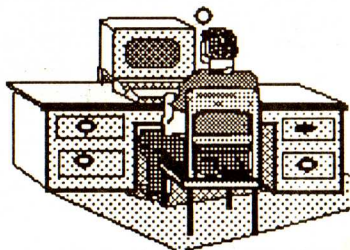

## Editorial Ramblings

COMDEX has come and gone, as has the Anaheim World of Atari show. Atari Corp. attended both events and there was lots to see for all.

The Michigan Atari Computer Expo will be over just about the time you read this, and contrary to any misinformation spread by a certain online "publication," Atari has stated they will have representatives at the Expo. At least one Atari U.S. executive has told us he will be at the show, and there will even be some Atari Canada execs at the Expo. Looking at that online publication's track record, the Atari community should be used to the factual inaccuracies they present. Perhaps that's why some online users have nicknamed them Z\*Rag and ST Z\*Rag?

Look for an in-depth feature on the Expo in the next issue of Atari Interface Magazine.

The second in the promised series of World of Atari shows nationwide will be taking place in Dearborn, Michigan on June 24 and 25. Atari will be attending this show as well, giving Michigan area Atarians a double dose of exposure. Atari Interface will give you complete coverage of this show as well.

See you next month.

Bill & Pattie Rayl

---

## Subscription Form

Name: \_\_\_\_\_

Address: \_\_\_\_\_

City: \_\_\_\_\_ State/Country: \_\_\_\_\_ ZIP: \_\_\_\_\_

I first saw your publication at: \_\_\_\_\_

I am most interested in the following subjects:

- |  |   |   |
|--|---|---|
| <input type="checkbox"/> Product Reviews | <input type="checkbox"/> Hardware Modifications | <input type="checkbox"/> Interviews with Developers |
| <input type="checkbox"/> User Group Info | <input type="checkbox"/> Current Atari News     | <input type="checkbox"/> Programming Tutorials      |

Please enter my subscription for  One Year (12 issues)  Two Years (24 issues)

Subscription rates: US — \$18 for 1yr, \$32 for 2yrs; Canadian — \$26 for 1yr, \$48 for 2yrs; Foreign — \$30 for 1yr, \$56 for 2 yrs  
Please make check or money order payable in US funds to Unicorn Publications

# Open your own art department.

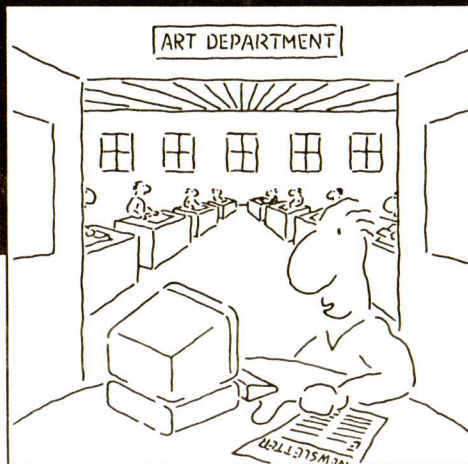

If you're a desktop publisher with big ideas and a small crew, let Migraph staff the desktop art department of your dreams.

Picture this: Professionally drawn images and illustrations at your fingertips. Powerful drawing tools, extensive editing tools, and a complete paint program at your command.

Plus high-quality printouts. Every time.

All that and compatibility, too. Migraph files load easily into your favorite Atari ST\* publishing programs.

Powerful. Versatile. And easy to use. Migraph's the ideal candidate for every job in your graphics department.

**Touch-Up™** The complete design tool for high-resolution monochrome images.

**Easy-Draw®** The professional object-oriented drawing program.

**Supercharged Easy-Draw®** Easy-Draw plus basic publishing features.

**Easy-Tools™** A 5-tool GEM desk accessory to enhance Easy-Draw.

**DrawArt Professional™** A library of over 150 professional line art drawings.

**Scan Art™** A library of over 100 high-resolution, bit-mapped images.

**Border Pack** A library of over 40 attention-getting border designs.

**OSpooler** A configurable background file spooler and print buffer.

Whatever desktop graphics project you have in mind — be it big or small, simple or ornate, traditional or avant-garde — Migraph's got you covered.

**See your Atari ST\* dealer today for more details.**



200 S. 333rd St., Suite 220 Federal Way, WA 98003 800/223-3729 206/838-4677

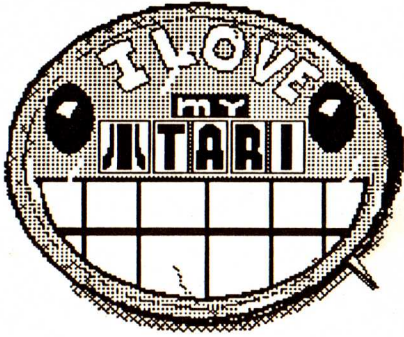

# Atari News and Comment

---

---

by Bill and Pattie Rayl

---

---

## Atari Corp. News

Sig Hartmann was recently promoted to replace Vincent Giametto as the Executive Vice President of Atari Corp. and the President of OEM Sales. Giametto was only recently promoted to the position Hartmann now holds, and it seems the Atari revolving door is still active.

Antonio Salerno, recently employed at Borland, is now in charge of Developer and Technical Support and Equipment Sales for Atari, duties recently performed by Cindy Claveran. His official title is Vice President of U.S. Software.

Other changes at Atari include the much-talked-about closing of the Federated chain of electronic stores. It seems the chain was quietly closed after the initial closing of 15 stores in the Western U.S. and the layoff of over 400 employees. Atari announced it was treating Federated as a discontinued company in the fiscal report from December, 1988 where Federated showed a loss of more than \$100 million in the last quarter of '88.

Atari had a strong showing at the Spring COMDEX show in Chicago recently. The new Atari Portfolio created quite a stir with coverage by USA Today, NBC and PBS's Computer Chronicles. The Portfolio is a small, hand-held, MS-DOS compatible computer with 128K and a 40x8 column screen. The Portfolio can be expanded to 640K and has ports for parallel and serial connections. The Portfolio comes with a word processor, spreadsheet (which creates files compatible with Lotus 1-2-3), database software and appointment book built-in. The

Portfolio retails for \$399 and uses Ram cards as disk drives.

The STacey, Atari's Laptop computer, was also on display to COMDEX goers. The STacey's base price will be \$1499, with option configurations for adding a 20Meg hard drive for a total of \$1999. The STacey is ST compatible, and has all the standard ports of an ST. Instead of a mouse, a small trackball is built-in to control the "mouse" cursor. There have been conflicting reports on whether Atari will change the name of the laptop from STacey to the Atari "Transportable."

Michigan Atarians may have the opportunity to view the STacey and Portfolio for themselves at the upcoming World of Atari Show in Dearborn, MI on June 24 and 25. This is the second in a series of shows planned by ST World Magazine, the first of which was the Anaheim World of Atari show. The Spectre GCR Macintosh emulator and the PC Ditto II were both displayed at the Anaheim show. No more information on the Anaheim show was available at this printing.

## New Products

A new Macintosh emulator for the ST will soon be released from San Francisco-based CEKA. The emulator plugs into the Mega expansion bus and doesn't use Mac ROMS! For 1040ST owners interested in the emulator, CEKA has developed a board that can be placed inside the ST with only five solder points. The emulator will retail for around \$350. For more information, call CEKA at (415) 474-2641.

A new hardware product is being developed for the 8bit Atari. This product, currently under the name "The

Black Box," is a parallel interface for the XL and XE computers. Bob Puff, creator of such 8bit utilities as DiskComm and SuperArc, put his skills to developing a hard drive interface with built-in RS-232 port and parallel printer port. The interface will be retailing for \$159, and you may add 64K extra RAM for a printer buffer for an additional \$40. An extra board can be installed allowing disk drives to be connected to the "Black Box." No price is yet available on this board. Bob Puff claimed users will be able to connect ST drives to the interface (perhaps in the XF551 case?). Using special software, users will be able to read ST-formatted disks on their 8bits, allowing information to be easily transferred between the two systems.

## Online News

GENie recently raised its hourly rates for the nighttime hours and lowered its rates for daytime use. GENie is now \$18 per hour during the day at any baud rate. After 6 p.m., the rates are \$5/hr at 300, \$6/hr at 1200 and \$12/hr at 2400 bauds.

The Byte Information Exchange (BIX) is offering two FREE online accounts to each User Group in exchange for including a BIX brochure in a club mailing and a small announcement in each newsletter and on any club BBS. In addition, each member of the User Group will receive a substantial discount on the BIX charges. Recently, BIX has changed from an hourly rate to a flat quarterly rate of \$39 for an annual subscription. Users calling through Tymenet may opt for a \$15 per month flat-rate fee for unlimited usage. For more information, please contact BIX at (800) 924-9281.



# Some Spellers are Better than Others.

Before she won her regional spelling bee, Margaret Hollingsworth pored over seven different dictionaries for more than three hundred hours.

And while we'd all like to be champion spellers, most of us just don't have that kind of time.

So may we suggest putting the WordPerfect® Speller in your corner.

Not only will the Speller check your document (or any section of it) for errors and double words, it will instantly count the words in a document, page, or block of text.

You can look a word up phonetically to find the correct spelling, and the Speller will give you a list of replacement words with similar sound patterns. Or if you're looking for

just the right word, and you know it begins with "s" and ends in "-ology," use a wild-card character to replace the unspecified letters. The Speller will show you a comprehensive list of your options.

With the WordPerfect Speller (included in your WordPerfect software for the Atari), more than 115,000 words are at your fingertips. No other speller can match that kind of power.

Not even Margaret.

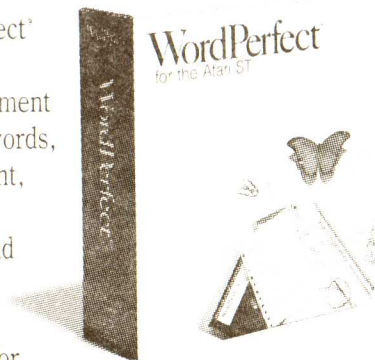

**WordPerfect**  
CORPORATION

1555 N. Technology Way · Orem, UT 84057  
Tel (801) 225-5000 · Telex 820618 · FAX (801) 222-4477

# I Love a Mystery...

## Except When the Stakes are So High!

---

---

by Gordon Totty (MACE)

---

---

This is an authentic "whodunit," a real mystery with lots of puzzles to solve, suspense, scary stuff, a good guy, a bad guy, and lots of lessons learned the hard way, which is the best way. This is a tale told by an idiot, me, and I hope that it signifies something useful to you.

It stars me as the defective detective, and as the bad guy. Late in the show, it stars Mike Olin as a guy in a white hat who comes to my rescue.

Stories today need sex in them to grab attention, so let's get right to that first. It is good to be back, and feel your hot eyes poring over my turgid prose. As your moist, plump thumbs smear my ink, everything I say seems fuzzy and out of focus.... There, that should hold your attention for a while. Now, let's get sensible and act my age, although acting your age might be more fun for me.

It was a dark and stormy night in early February, 1989. I was alone in my study, unaware of the events that were about to befall me and plunge me into the depths of despair for the next several weeks. The love of my life, the Atari 1040ST, was in my arms and, in spite of the cold, I was sweating from exertion. I had rolled the little beauty up in the air and ripped out her mouse, with no small effort. I struggled to insert the plug from a MicroFlyte joystick into her mouse port. At last I succeeded and put the computer back down.

If you have never tried this, you might think I am exaggerating the effort it took. I am not. It is a tough job, especially if you have the older mouse plug

without the metal band around it. That plug is tough to pull out. Inserting it, or a MicroFlyte plug in its place, is harder still. The port is hard to reach, and you have to approach it at a near-perfect angle, which the designer decided should be almost impossible to do with the clearances he allowed. Picture me with low light under the computer, my neck straining because of the bifocal burden, only one hand free for the job because the other hand is holding the computer up, and you might begin to understand that I was sweating in February.

You see, in addition to the physical strain, I was worried. Five cables come out of the back of the computer, and I didn't want to stress (or strain) them too much. I have had experience with a cable failure at work, and do not want to repeat the experience at home. Also, dangling out of the cartridge slot on the left, I have a cartridge accessory. It was swinging around in space as I wrestled with the plugs.

After succeeding, I booted Flight Simulator II to try out the new stick. I didn't like it. It seemed to operate in a very sporadic manner, but I didn't think anything of it at first because the instructions said that I might have to set or calibrate it.

The next day, the MicroFlyte stick would not operate at all. I tried everything I could think of, and concluded that it was broken. I packed it in its box, and sent it back to the folks who asked me to try it out. I asked them to let me know if it was broken, because I had begun to notice that strange things were happening. Ho, ho. Hee, hee. (Where are you, Red Buttons?)

At first, the reinstalled mouse would

not operate. The cursor could not be moved with the arrow keys. The MicroFlyte has its own built in computer chip. Could a bad chip have "attacked" my good mouse port chip, or circuit, or memory? A Trojan horse joystick? A virus? Holey moley, Batman! Leaping lizards, Annie! My love was running a fever, and the new stick was the only thing it had been exposed to, right?

(If you have solved the mystery at this point, with only one clue given, you are an EXPERT! I am not. I was completely in the dark at this point, and beginning to entertain dreadful fears. The 1040 is the monkey on my back, and thinking of a trip to the shop was already making me act like Frank Sinatra in "Man With A Golden Arm," or Don Murray in "A Hatful of Rain.")

Things got better; then they got worse. The next morning, I booted up before going to work, as if to check whether the events of the previous night were just a nightmare out of Edgar Allan Poe. Everything was working. I rubbed my eyes, and looked again. Everything was working! I soared off to work. Life was good again. Birds chirped in February. But not for long.

Other problems began to occur, with a frequency of once or twice per week. I should point out that I turn the computer on about five out of every seven days. My wife would tell you, "Seven out of seven is more like it!" but she exaggerates a lot.

One day, I booted up and tried to use my word processor. Things worked, but in slow motion. Commands took five to ten seconds to be implemented. I rebooted, and everything was fine. I wondered if perhaps I had not followed the instruction for starting the hard drive (turn it on



and wait about 15 seconds before turning on the computer). What gives here? This was the strangest problem I had ever seen.

Another day, using 1st Word with the hard drive off, I was typing an article for a magazine. I was thinking, between typing bursts, and just leaning back looking at the screen. I was not touching anything. All of a sudden, the cursor-arrow turned into a "busy bee" and then the infamous row of bombs appeared. The machine locked up. I lost my file! (Honest, folks, it was the best stuff I have ever written in my life, but no one will see it now. It is gone into some electronic limbo. It now has as much meaning as that tree that fell in the forest that noone heard.)

The next day, a helpful expert at the office told me his theory that the program tried to do an automatic backup to the hard drive, which was turned off. When it failed, it crashed. I thought there might be something to this theory. I had booted with my normal boot disk, which includes the hard drive booting software and Universal Item Selector II. I could hardly wait to get home from work to check the 1st Word documentation. I don't use that program much, and wasn't familiar enough with it to know, while at the office, that there is no automatic backup feature. Well, it was a good theory for a while. It made me feel good all afternoon that day.

February was a cold, dry month. The furnace ran quite a bit. Our furnace was not equipped with an automatic humidifier. There was a deep, dry, chill in my bones.

(How are you hackers doing? Anyone got the answer? If I wasn't so cheap, I'd make this a contest and award prizes for the earliest correct answer ... assuming I know what it is!)

Another day, I was typing a letter to dear old Mom using my word processor and the hard disk. Out of the blue, I was treated to the sight of six or seven bombs! I didn't do anything wrong; this was unfair. Total lockup; another lost file. Sorry, Ma. Maybe I'll call.

I have used Atari computers, a 400, 800, XL, XE, and ST, for over five years. Since drop kicking the 410 recorder out the door, I have never lost anything. I have laughed at the advice about backing things up. I have ignored all the safety rules. I have enjoyed very reliable computers, disks, and disk drives. What I was enduring now was alien to me. Perplexing. Frightening. Frustrating. I resorted to strange practices. I implemented the automatic backup feature of WordPerfect, and set it for timed backup at every ten minutes. Extreme conditions call for extreme measures! I was in a foxhole; I was beginning to get "religion."

One other evening, I was entering records in my data base. I had about 50 records posted, when I turned away from the machine to get some more data. When I looked back, I was astounded to see the desktop. No bombs. No lockup. But, no saved file, either!

I shut off the hard drive, and rebooted from drive A. While inputting data, I saved to drive B after every ten or fifteen records. I entered 120 records with no problem. I am now a frequent saver, even when I do not have an automatic backup program to think for me.

Later that evening, the system crashed while switching disks in drive A.

More help from the experts at work! It was suggested to me that static electricity could be the culprit. Even though I wondered how I might have caused a crash and lock up while not touching anything, I immediately put a large evaporation pan in the room with the computer. Also, I resolved to install the furnace humidifier that had been sitting in the basement, brand new in its carton, for over a year. It was installed in a day or two. After all, I do have my priorities to think about.

By this point in time, late February, I had developed a list of suspects. Like good detectives, let us consider them one by one. They are waiting for us in the parlor.

The Hard Disk. Not a leading candidate. Two problems occurred when it was off, and I had no trouble at all during the first five weeks of its use. Of course, just because it was running right for a while doesn't mean it will be right forever. After all, a bank robber is not a criminal, until he pulls his first heist.

DeskCart! and/or its associated boot software, including the Universal Item Selector. I booted with this every time that I had a problem, except for the first instance with Flight Simulator II. However, this combination worked flawlessly for about a year preceding February. Besides, for the software, I would expect a problem on booting, but not later in the middle of an application program. What do you think?

Static electricity. For a while I was sure that this was the problem, except that I continued to have difficulty after raising the humidity. Do you think I need more humidity? An anti-static mat? I have a friend who sent two PC keyboards to the shop with jolts that leaped from his fingers.

Mouse, or the mouse port or pins. The mouse was not directly active during most, if not all, problem incidents, so this was not a strong suspect. Nevertheless, it is a rodent; like a rat it is not to be trusted!

Computer. The trusty, reliable, Atari 1040ST might be starting to fail. Since the problems usually occurred after some period of use, I suspected a heat related failure.

MicroFlyte's joystick. Could it have caused damage to the computer's circuits? After all, I had no difficulty prior to attempting to use this product, and all kinds of difficulty afterwards. (Anyone know what post hoc ergo propter hoc means? It refers to a fallacy in logic based on few or single instances of an occurrence. The fallacy is to conclude, "after this therefore because of this", or something like that. Well, can the Latin crap, this hoc was my main suspect for a long time!)

Well, all you "Murder, She Wrote" fans, whodunit? All of the suspects that I gathered above are innocent except one. That one was guilty, but not in the way I then considered to be likely.

Let's get back to the tale of tears. There were more shed before the truth leapt up and punched me in the kisser. Hey, I wasn't crying, for crying out loud. I'm a private eye guy on a case, and tougher than a two dollar steak!

Late one night, when I didn't expect it, my word processor

displayed three bombs and the computer locked up. Another lost file.

On shutting down one other night, with the hard drive off and the desktop showing, I bombed while taking a disk out of drive A. This was getting to be a habit, a bad habit.

With a different database program, and 40 records waiting to be saved (what happened to saving every ten or fifteen? ... how quickly I forgot), I looked up and saw ten bombs on the screen! I rebooted and in five minutes got three bombs. In both cases, I was not touching anything when it happened. Also, there was no disk activity. Earlier that evening, the kids had used a game for 45 minutes with no problem.

Throughout this period, no game ever bombed or locked up. (Could this be why the Atari is a good game machine?) Trouble always happened with productivity software in use, or during shutdown from productivity applications. This is one reason I suspected the boot disk. It is not usually used with games.

I tried to provoke a lock up or bomb out by wiggling all the connecting cords and cables. Nothing produced bombs except wiggling the DeskCart!, an unnatural act. I decided the problem lay elsewhere.

The grief continued. I was far closer to solving this than I realized at that time. Have you got any ideas? Who or what do you want to put the pinch on?

Four days later, while using my word processor, two bombs appeared and I was kicked back to the desktop. The computer did not lock up; I was just kicked out of the application program without an opportunity to save the file. The file was largely recoverable because I was using an automatic backup option. I decided to reset the backup option to do a save every five minutes.

That same day, I finished typing a letter, saved it, and tried to print it. The computer immediately locked up, with four bombs displayed on the word processing screen. The busy bee icon was frozen on the screen. The busy bee was a dead bee. Nothing worked. I rebooted, and recalled the file, which I had saved, and printed it with no problem.

For many days, I had been considering what I would do while the ST was in the shop for repairs, which is where I was sure it was heading.

Fellow detectives, I have read that the number of bombs displayed is valuable information pertaining to what went wrong. I was recording the number for possible use by a service technician. So far, I had noted two, three, five, six, (maybe seven, once), eight, nine, and ten bombs, sometimes with total lockup and sometimes without. Sometimes I was just returned to the desktop. I love a mystery, don't you? My hair was falling out over this one!

I do not like contemplating a potentially expensive repair. My flesh crawls at the thought of the ST being gone from my home for one, two, or more weeks. I had visions of being told, "Sorry, we had to send your unit to Taiwan. The airfare was high, so we sent it by ship — out of New York." And then, in my nightmare

vision, I would read that the Panama Canal was closed for repairs. The worst nightmares are those that only go away when you are asleep, if you can get to sleep. My brain was constantly considering possibilities, probabilities, suspects and clues. This case must be solved!!

I could have bought an ST520 during the recent MACE swap night for \$200. Why, oh why, didn't I do it. It would serve me well, while the 1040 is in the shop. Thinking like this made me realize the degree to which I have abandoned the XL, which sits right next to my ST. When this dawned on my consciousness, I began to focus on the fun that I might have renewing acquaintances with the XL, my old girl friend, and I found some small comfort in that thought.

The next day, I began to unravel the mystery. The case was cracking like an Easter egg in the hands of a hungry five-year-old. From here on, it would be like taking candy from that baby.

I was again putting records into a database. As is my custom, the material I was reading from was on my left, to leave the mouse clear for use on my right. I put some material away, and put a disk case in its place. The disk case touched the DeskCart! cartridge. Wham!!! Nine bombs — locked up — 27 records lost, but I sat there smiling, with a cigarette hanging out of my mouth and my beat-up hat perched on my head at a cock-eyed angle. Eureka! (Oops! Forget that Greek stuff.)

"Gotcha, you varmint!" I drawled. (Oops. Forget that Western stuff.)

The truth slammed into my guts like a hot slug from a cold 45. At least, that's what I thought. How many of you are prepared to blame the cartridge? Read on, maybe more of you will join me in blaming the cartridge. Let's slam it in a chair, under a hot light.

I decided to run some tests:

1.) From the desktop, I wiggled the cartridge slightly. The computer rebooted. I did this twice, just to make sure it was no fluke. Bingo, and bingo again.

2.) I loaded my word processor and touched the cartridge. This time I got three bombs on the screen and a locked up computer. This is getting interesting.

3.) I loaded my database and slightly lifted the cartridge. Again, I got three bombs, but this time the computer did not lock up. Instead, I was kicked back to the desktop. On continuing to use the computer I noted weird effects. Mouse operation was erratic, with very slow reaction from the computer to commands input by the mouse. I hit the reset button to start over, and was again surprised. The computer locked up during rebooting.

At this point, I believed that I had rather successfully duplicated all of my problems, merely by disturbing the cartridge. Could the cartridge be failing? Is this what happens when the battery in DeskCart! is failing?

I slid into my old trench coat, shoved the suspect cartridge into my pocket, and drove my beat-up Mustang to United Computer, where I bought DeskCart! over a year ago (warranty expired, naturally). Mike Olin (cheer) tried it out on a machine in

the store. It slid into the port very snugly; it is loose in my machine. Tapping, banging, and wiggling it did not produce any problems. Good grief, now what?

Mike suggested that the problem likely was in the slot itself, and that maybe the contacts were too loose. He told me how to try to fix this myself, without opening the computer. He cautioned me that everything should be turned off before I touched anything. He reassured me, that this type of repair, even in the shop, would be quick and easy. I went home and tried his advice. It worked.

Total cost of repair: \$0. Time to perform repair: 5 minutes (10 if we count how long it took me to find my jeweler's screw drivers).

Mike Olin is a "brother" from MACE. He knows more about computers than I do. This is why I belong to MACE, for support. Mike also works at United Computer. This is why I do a lot of my shopping locally, for customer support. In fact, I was so grateful for the free advice that I went out of my way to make a purchase while I was still in the store. I now own Atari Planetarium for the ST. Some of you will remember the impressive demonstration of the 8bit version of this program at a MACE meeting a while ago. What goes around comes around ... and sometimes it is something good.

Now, for the big wrap up, the final reel in this thriller. The

lessons I learned, or re-learned, are:

- ❑ Always back up your files frequently. Even computers that have operated flawlessly for years can get into unforeseeable difficulty some day. Be prepared; be protected.
- ❑ Use all of the protection features that may be available to you. If your word processor has automatic back up, activate it.
- ❑ Be careful about moving your computer. Installing the MicroFlyte joystick was harmful to the cartridge port. I should have removed the cartridge first, instead of letting it dangle in space and possibly further deteriorate its loose connection to the computer.
- ❑ Beware of hasty conclusions. At various points, I was sure the problem was coming from my innocent hard disk, certain software, the DeskCart! cartridge itself, or had been caused by the MicroFlyte joystick. All such conclusions were false. Sorry, DeskCart! Sorry, MicroFlyte.
- ❑ Support your user group and your local merchant. They can support you. Thanks, Mike. You ended my six week nightmare.

Now, the big sleep comes easy again.

New Improved  
Version

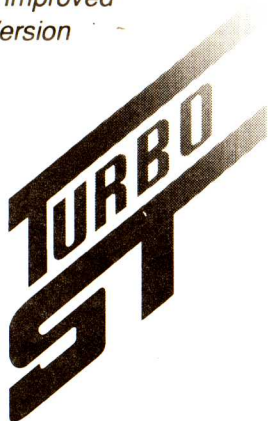

By



P.O. Box 5257  
Winter Park, Florida 32793  
(407) 657-4611

— **FASTER THAN A SPEEDING BLITTER !!**

- Makes your 520 / 1040 ST™ outrun a Mega ST™.
- New version supports HiRes 40 and 50 line modes.
- Makes ALL versions of TOS run faster.
- Only \$49.95 — Less than half the cost of a hardware blitter.
- Installs automatically — just load it and forget it.
- No soldering, no copy protection, no setup — Just speed.

**Turbo ST vs The Blitter (% speed increase)**

	Monochrome		Color	
	Blitter	Turbo ST	Blitter	Turbo ST
dBMan 5.0	10%	59%	8%	60%
Data Manager 1.1	83	94	85	88
1ST Word 1.0	37	35	34	41
GFA BASIC 2.0	22	69	13	65
Interlink 1.8	53	63	46	71
ST BASIC 1.0	221	517	219	567
ST Writer 3.0	18	116	17	127
Word Writer 2.0	34	31	35	37

Results obtained while paging through an appropriate data file.

Ask for Turbo ST at your local dealer or send \$49.95 plus \$2.00 shipping and handling to SofTrek, P.O. Box 5257, Winter Park, FL 32793. Florida residents add 6% sales tax. Visa and MasterCard phone orders accepted. Call (407) 657-4611. Upgrades to version 1.4 are available for \$5.00 U.S. plus your original disk. Offer expires 60 days from the date of this publication.

Turbo ST does not speed up programs that use GDOS fonts or that bypass the GEM operating system, such as PC Ditto, but is compatible with them. TOS, ST BASIC, ST Writer, 520 ST, 1040 ST, and Mega ST are trademarks or registered trademarks of Atari Corp.

**Get In The Fast Lane — Buy Turbo ST Today!**

# Computers and Education

by G.L. Ray (TACE)

I don't get on a soapbox very often. But I encountered something this past week that moved me to write this piece. The subject I want to explore is the connection between computers and the classroom; how many computers are needed and how they should be utilized.

Let me explain how I use computers in my classroom. I have two 130XE systems of my own which I take to school to use in my classroom. I also have two Panasonic 1091i II printers connected to MPP 1150 interfaces. I teach 7th- and 8th-grade art in a medium-sized junior high school. We utilize the computers in several ways.

First of all, as a teacher, I use the computer to record and average grades. Another way I utilize a computer is to maintain a student database. Such information as student phone numbers, addresses, and parents names can come in very handy. I also use my word processor continuously to produce handouts, quizzes, and assignments. I can keep lots of assignments and handouts on one easily found disk. (My file cabinets are not known to be very tidy. On the other hand, my disk library is a model of efficiency.)

If the above were the only reasons for a computer in the classroom, for me it would be enough, but the students utilize the computer also. First of all, students use the computer as a means of creating art. I use Rambrandt, the design studio software from Antic Magazine, as a tool for creating artwork on the computer screen. As an assignment, each student is

to create a drawing on the computer, print it out, and mat it for display. A second assignment is to create a graphic printout with various application programs, such as Printshop, PrintPower, and Awardware.

The most ambitious project for my students has been producing a school newspaper. Students utilized the word processor, Printshop, Crossword Magic, and a WordFind program from Antic magazine in creating their first newspaper.

Now, what value do the students receive from using a computer? Don't real artists paint with brushes not joysticks? Is a computer really necessary to teach art?

Well, yes and no. I could teach art with nothing but a pencil and a sheet of paper. But I choose to also include brushes and paints, pen and ink, screen printing and numerous other materials and tools. The computer is just another tool I utilize in teaching design, creativity, and all of the other aspects involved in an artwork.

My view on the use of the computer in the classroom differs with the traditional viewpoint. The traditional view puts the computer in a computer lab where students learn to program in BASIC, utilize a word processor, and maybe some drill practice on math or history facts. Computers are used to learn about computers or to take the place of flashcards.

I have two strong arguments against this format. First of all, who gets access to these computer labs? Usually, only the top students. The majority are left out in the cold. Second, how can computers in a lab setting prepare students for real world applications? Computer labs dwell on

computer programming/operation and drill practice, not on problem solving and creativity.

I believe that the computer can be utilized in every subject taught. An English teacher can let students type their own poems and short stories. An Economics teacher can assign students to key in the latest figures into a stock market simulation. Science fair projects can be accentuated with graphics, signs, and banners using Printshop. I could go on and on, but you get the picture.

In the real world people don't use computers to learn how to program in BASIC. They use computers for spreadsheets and word processing and desktop publishing and telecommunications. Computers are used as a tool to solve problems. And that is exactly how computers should be used in the classroom. Computers should not be removed from the rest of the curriculum, but integrated within it. Teach students how to utilize the computer to get things done...on the job training, so to speak.

How many computers will this take? Several computers will be needed in each classroom, obviously more than most schools wish to spend. But yet, maybe not. Not all teachers are ready, or willing to take this approach. Some teachers that I work with are terrified with the computer. Let's just start with those adventurous souls ready to expand the education process, and put a few in each classroom, always expanding each year as there is need.

And whoever said that computers have to be IBM or Apple? I could install three to four Atari systems for each IBM or Apple and accomplish every bit as much. You see, it's not the computer sys-

tem used that is important, it's how the computers are put to use. The principles are the same.

Our school has received a \$50,000 computer grant for our library. But we can only buy certain EDUCATIONAL software to run on IBM or APPLE computers. And we can't have more than a certain number of computers unless we put them in a computer lab format. And what does all of this accomplish? It gives teachers something to let students do when they get finished with their regular assignments...they can go to the library and PLAY on the computer.

I am sure that other views on computers and education have their good points, but to me, we are missing the boat. Let's integrate computers into all aspects of the curriculum, allowing all students to learn how computers can enrich their lives. Let each classroom have computers as part of their equipment. Teachers can then use the computer in any number of creative ways right there in the classroom. They can even let the kids PLAY on the computers when they get their regular assignments done, and run some of that EDUCATIONAL software. But, just think of the many other things that could be done....



## Best Electronics

2021 The Alameda Suite 290  
San Jose, CA 95126  
408-243-6950

### ⌘ ST/MEGA ⌘

Michtron Eprom Burner (up to 512K eproms) \$199  
Atari SH204 Host Adapter This is the cheapest Atari hard drive host adapter available. Can be used with standard hard drive controller cards like the Adaptec 4000A. Great for building low cost hard drive systems. \$60  
P.C. Ditto cable kit (3 ft cable with installed 14 connector one side and bare wires the other side and 34 edge connector + pin outs) \$10 ea.  
Because you asked for them we have brought in! 3 ft SC1224 and SM124 monitor extension cables! (M to F) For use with Goldstar and Samsung monitors with one sided short cables \$25  
13 pin Female cable connectors \$4.75  
14 Pin Female cable connectors \$5.60  
(Use these 14 pin Female connectors with a standard printer switch box and make a drive switch box for P.C. Ditto drives)  
Mouse Feet (our feet have twice as much teflon material) \$4 pk (4)  
Mouse Eyes (Taiwan mouse only) 8pk (one mouse set) \$5  
Mouse Cleaning Kit by Tacklind \$12.95  
Mega Keyboard Covers \$8.50 ea.



### ⌘ 400/800/XL/XE ⌘

Digital Devices APE-LINK Kits (adds extra SIO Connectors to Your Atari Daisy Chain) Bare P.C. Board \$10 Kit \$21  
1030 Modem Special! 29.95  
New 256K Atari Game Cartridges in stock. See our catalogue for listing!  
Thomson Proburner Eprom Burner \$149.00  
XL Keyboard Mylars in stock now! \$22 ea  
In Stock 130XE Cartridge Connectors \$6.30  
Many people have asked which Mailing List program we use at Best Electronics, we currently use Super Mailer+ from Royal Software. Super Mailer program (D) \$39.95  
XL to XE Software Compatabilty Mod by Tom Lawless. This two chip/switch mod is for enhanced 800XL computers (256K-512K). \$8  
**Hardware upgrade kits and P.C. boards that require the 41256K ram chips have been put on hold because of the high price of ram chips. We hope to ship again once ram chip prices start to drop down!**

# Atari/Imagen UltraScript Postscript Emulator

---

---

by Richard L. Brice

---

---

Copyright 1989, Dayton, Ohio. Reprinted with permission of CompuServe and the author.

The UltraScript Postscript Emulator for the Atari SLM-804 Laser Printer is probably one of the most exciting products to surface for the ST series of computers. When it was first introduced, the SLM-804 was extremely limited in its capability. The Diablo 630 emulation was flaky at best. The GDOS output routines were much improved from previous releases but user hostility toward GDOS curbed interest in the printer. It was cheap, but other low cost lasers offered Epson emulation and HP Laser Jet (an industry standard) emulation as basic capability. It simply wasn't a good business decision to buy the 804. The advent of UltraScript changes all of that. Postscript emulation for the "dumb" 804 makes it a real value. Should the emulation be developed for other printers using the Mega ST the serial or parallel interface is still slower than the DMA interface of the Mega/804. Crude benchmarks show that UltraScript will deliver a printed page approximately 10 times faster than the Apple Laserwriter Plus running with a Mac SE. What we have here is real value.

UltraScript currently requires that your application be able to print a Postscript file to disk which may then be processed by the emulator later. This does not, in my opinion, present a problem. Do your work, exit to the printer, setup, print, and go have a beer. The print function ties up the computer anyhow so I

would just as soon batch print everything at once. Either native "Quickdraw" or GDOS routines may be used for draft print-out as you go along.

Now, how do we use the system? What programs are available for use with UltraScript? Surprisingly enough, several first rate programs are in place. By accident or design, PageStream from Soft Logik is optimized for Postscript. That program is possibly one of the most powerful page layout programs available for any computer regardless of price. Fleet Street Publisher from Michtron is another Postscript compatible for the ST. Fleet Street has its charm in the ability to have GEM screen fonts while accessing Postscript fonts for output. With a little work and a good GEM font editor (Fontz! from Neconcept is recommended) you can achieve a true WYSIWYG screen display with Fleet Street. The Timeworks Desktop Publisher can also write a Postscript file to disk. Unfortunately, the interface is, in my opinion, a kludge. A file called "PUBLISH.PS" is written to disk each time you invoke the print command. This file is constantly overwritten. It is also impossible to change the screen fonts or to add additional Postscript fonts to the font list. It is unfortunate that Atari chose the Timeworks program to bundle with the SLM-804 Postscript package. It is an excellent program, but just not suitable to the vast capabilities of Postscript. Thanks to Gadgets by Small, we aren't necessarily limited to Atari programs. The Spectre 128 opens up the world of MacIntosh programs. Of all the page layout programs for the Mac, Pagemaker seems to offer the best interface with UltraScript. It seems that any Postscript file saved from Mac applications contains

a prologue written by the Apple Laser Prep program. This prologue is totally incompatible with UltraScript. But, take heart, Pagemaker uses Aldus Prep which is completely compatible with UltraScript. Further, both Illustrator and Freehand run well on Spectre allowing for high quality Postscript illustrations which may be placed and printed through Pagemaker. While total Mac interoperability can not be achieved due to the eccentricities of Apple Laser Prep, you can get Postscript output through Pagemaker which should satisfy any requirements you might have. Although I have not made any investigation of the PC world, I would assume Pagemaker provides the same bridge capabilities from the IBM.

Before I digress into a discussion of how to make UltraScript work with specific programs, let me spend a little time on how the program itself works. You may install it on your hard disk. The test article was evaluated using a Mega 4, with 30mb hard disk, and the SLM-804. The "4" provides sufficient memory for the complete Laserwriter Plus fontset plus the entire Lucida font set with no problems. I cannot say what the font limit is as yet but we are working on that. The program, when run, is simplicity itself. You are presented with a screen that looks very similar to the Outprint screen from Migraph's Easy Draw. The program works almost identically to Easy Draw Outprint. There are 35 "slots" for filenames. You add names to the list and invoke the "Print" command and UltraScript does its thing. Simple enough. You have options for multiple copies as well as an option to enter the UltraScript Executive. In a month of heavy use, I have

never had the program "lock up" or "bomb". If it encounters a problem it advises that it has encountered an "offending command" and is "flushing to end of job" and then stands by for the next print command. This is, by far, one of the most solid ST programs I have ever encountered.

As to how you get it to work with the various programs available, let me review each in turn:

**PageStream.** As I mentioned, the program is optimized for Postscript. You may use the PageStream fonts after you have converted them to PS output files as per the instructions that are included with their font converter. Unfortunately, their fonts are not that good and in that their Postscript output routine defines each font, it writes some incredibly long files. To make PageStream recognize the Ultrascript (resident?) fonts you must do several things, again using the Font Converter. The UMETRICS file provided with Ultrascript contains AFM files for each font. These AFM files may be loaded into the converter, and the program automatically writes a corresponding .FM and PSF file. A screen font may then be generated by importing the Pub Partner font and generating a .12H screen font. You must assure that the ID numbers agree with those recommended by Soft-Logik (see their doc file on the converter). Unfortunately, PageStream screen font representation is wretched because they use the one 12 point font and scale up or down from that. The good news is that the alignment is ok. You merely have to endure a not so WYSIWYG screen presentation. I don't consider that to be a show stopper, considering the other capabilities of PageStream. I am working with Soft-Logik to solve the screen font problem.

**Timeworks Desktop Publisher.** The program works. A PS driver is now available that outputs to disk, subject to the restrictions mentioned above. Here's how you interface the program with Ultrascript:

1. Rename the PS driver to PRINTER.SYS and copy it to your GEMSYS folder.
2. Run FONTWID.APP and say yes to the query on Postscript printers and select Laserwriter Plus.
3. Run PUBLISH.APP. You will see that Laserwriter fonts are available for selection at any point size. The problem is that only eight are available. Helvetica Narrow and Dingbats are not accessible. Further, the screen representation uses only Swiss (for all sans serif fonts) and Dutch (for serif). This includes Chancery. A very un-WYSIWYG presentation which is marginally acceptable. If Timeworks DTP is all you have then it will work but don't expect to tap the full capabilities of Postscript with it.

**Fleet Street Publisher.** FSP allows you to include new Postscript fonts and to assign GEM screen fonts to the Postscript fonts. GEM screen fonts are easily generated by Fontz using the

public domain screen fonts for the Macintosh. To explain how the fonts are harmonized in the program would take pages, but you do it with the Set Defaults option. My only suggestion is to read the section in FSP documentation on Inside Fleet Street Publisher and Set Defaults...several times. The good news is that you have, with FSP, a true WYSIWYG presentation. The program has a lot of flexibility in working with type but is somewhat limited in graphics (pretty much limited to bitmap stuff for now). All in all, however FSP may present the ideal low-end layout package for use with Ultrascript. The 2.0 version now sold by Michtron is much improved over the original.

**Other GDOS Programs.** In theory, all GDOS programs should work properly with the PS driver. Easy Draw functions fine. There is a problem getting Write and WordUp to recognize the fonts.

**Macintosh Programs.** As I mentioned previously, most of those Macintosh programs used by desktop publishers run with no problem on the Spectre 128. Aldus Pagemaker creates a Postscript file that is compatible with Ultrascript. Therefore, almost anything you can do on the Mac can be placed in Pagemaker and output as a Postscript file. The procedure for this is fairly simple. First, you have to have made a choice of some laser printer with the chooser. Having done that, select print from the file dialogue. Hold down the ALT key and click on the OK button. Wait for the Postscript options menu to show. De-select "download bitmapped

fonts". Select "Write Postscript File to Disk" and choose either Normal or EPS. Remember to save the file on an MFS formatted floppy in order to transvert the file to the ST for Ultrascript printout. That's all there is to it.

I do believe that the advent of the Ultrascript emulator brings the ST out of the realm of a "Super Game Machine" and into the realm of a serious 16-bit business computer. It realizes the true potential of the SLM-804. You can now realize the dream of an inexpensive, high quality, and extremely fast personal laser printer. The speed is important. Although I have not run any controlled benchmark tests, preliminary experience shows that Ultrascript and the 804 turns out a Postscript page approximately 10 (yes I said 10) times faster than the Laserwriter Plus. Worst case, a Mega 4, Megafile 30, and an SLM-804 (with Ultrascript) gives you the same capability as a 4 meg Macintosh Plus with hard drive and a Laserwriter Plus with 3.5 megs of RAM for under \$5,000. I invite you to price out the Mac package.

Any dedicated Atari ST user needs to consider the implications of Ultrascript. With it, the Spectre 128, and the new PC Ditto II hardware IBM PC emulator for the ST you have a triple threat capability that is real.

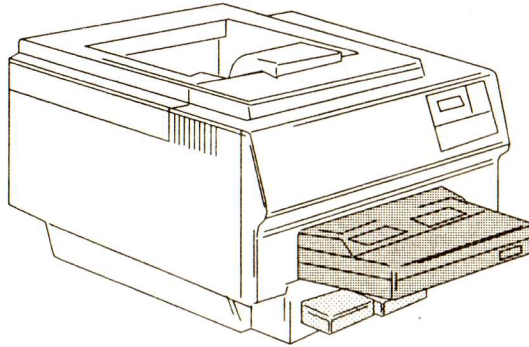

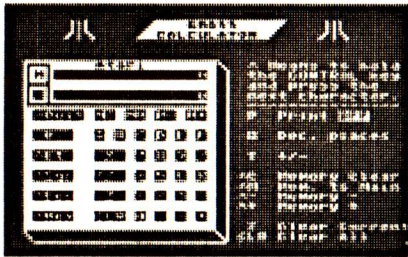

# The GRASS Calculator

---

by Gary Heitz (GRASS)

---

The GRASS Calculator was created as part of the Grand Rapids Atari System Supporters' BASIC programming class. We started by explaining cursor controls and simple PRINT and POSITION statements.

A simple calculator was used to demonstrate these commands and to explain the math operations. As time went by, the simple calculator became more involved and grew as new features were added.

One unusual feature that was included affected how the calculator's memory worked. On a normal calculator, you store something in memory but unless you have a pretty good memory yourself, you can easily forget what you stored there. The GRASS Calculator has two number displays. One is like that on any calculator -- the main display. The second one always shows what has been stored in the memory.

The other features of the GRASS Calculator are:

- Print - will print to a printer just like a more expensive printing calculator will do.
- Change decimal places - will either display your number normally with no alterations to any decimal places, or it will round the number's decimal places to the nearest hundredths.

- Change signs - This feature is like the +/- key on most calculators. It will change the current number from positive to negative or vice versa.
- Four memory keys - Memory + (add to memory), Memory - (subtract from memory), Memory (display the contents of memory in the main display), and Memory Clear (clears the memory).
- Clear and All Clear - Clear erases the number you are currently entering (good for when your finger goes a little crazy on you and hits the wrong key). All Clear will clear everything in the main display. It does not clear the memory, though.
- Root and Square Root
- Decimal to Hexadecimal Conversions
- Hexadecimal to Decimal Conversions
- Percent - This will convert a number into its percent.
- Quit - I added this feature because it allows for a clean exit from the calculator without having to hit the RESET button.

Because the GRASS Calculator is not just for adults with perfect coordination, which does not include myself, I have added some "safety" features. The BREAK key will not work. The two other keys that will get you nowhere are

the Atari, or inverse, key and the Caps key. If you hit one of these keys by accident, there is no need to worry; they will be ignored.

Here's an idea for any BASIC programmers out there or anyone interested. If you renumber this program to begin with a high line number, like 30000, you can do your programming and GOTO the first line of the calculator to use it and QUIT when you are done with your calculations. This way you don't have to keep loading and reloading the program you are working on.

One last thing to mention. The two inverse letters that precede each line in the type-in program are checksums. They work the same as any BASIC program that you find in Antic or ANALOG. You can use either of their type-in programs to type in the GRASS Calculator.

I hope you enjoy using it.

[*Editor's Note:* The type-in program for the GRASS Calculator begins on the following page. A copy of the program can also be downloaded from the AIM area on the Treasure CheST BBS, (313) 973-9137, 300/1200/2400 baud.]



NOTE: The following listing contains "shorthand" versions for many non-printable characters. Examples of some of the codes and their descriptions are:

- [Inv] = Press the Inverse Key once
- [Norm] = Press the Inverse Key again to toggle back to normal mode
- [# Sp] = Type # number of spaces
- [# X] = Type # number of character X (i.e., [3 \*] means type 3 asterisks)
- [^X] = Hold down Control while pressing the X key
- Sft X] = Hold down Shift while pressing the X key

In all these cases, DO NOT type the brackets; the brackets serve only to delimit the "non-printable" characters.

Also, any time you see what appears to be control characters outside of brackets, such as ^C, these characters should be typed as the ^ (caret) followed by the character in the listing.

One or two spaces in the listing are displayed as spaces and should be typed as shown. Only when more than two spaces appear together are they represented in "shorthand."

```

L Z 10 REM SAVE "D:GRASSCAL.BAS
G J 20 REM .[Inv][^Q][27 ^R][^E][Norm]
Q I 30 REM .[Inv][Sft =] Grand Rapids Atari System [Sft =][Norm]
A G 40 REM .[Inv][Sft =][8 Sp]Supporters[9 Sp][Sft =][Norm]
B G 50 REM .[Inv][Sft =][27 Sp][Sft =][Norm]
C O 60 REM .[Inv][Sft =][8 Sp]Present the[8 Sp][Sft =][Norm]
B I 70 REM .[Inv][Sft =][27 Sp][Sft =][Norm]
M S 80 REM .[Inv][Sft =][3 Sp][^H][Norm] GRASS Calculator [^H][Inv][3 Sp][Sft =][Norm]
B K 90 REM .[Inv][Sft =][27 Sp][Sft =][Norm]
S G 100 REM [Inv][Sft =][8 Sp]Written by:[8 Sp][Sft =][Norm]
K J 110 REM [Inv][Sft =] Gary Heitz & Tim Feenstra [Sft =][Norm]
J J 120 REM [Inv][^Z][27 ^R][^C][Norm]
Q U 130 CLR
W R 140 DIM OP$(1),CL$(15),IN$(15),DISPLAY$(15),HEX$(15),DEC$(1),TEMP$(17)
R Q 150 CL$ = "[15 Sp]"
G B 160 GRAPHICS 0:GOSUB 1900
V C 170 POKE 710,0:POKE 709,12
J V 180 POKE 752,1
X N 190 CLOSE #1:OPEN #1,4,0,"K:"
Q N 200 REM [Inv][3 *] DISPLAY [3 *][Norm]
H Q 210 POSITION 2,1
O I 220 ? "[4 Sp][^B][Sft =][^V][5 Sp][^H][Inv][3 Sp]GRASS[4 Sp][^H][Norm][3 Sp][^B][Sft =][^V]"
X A 230 ? "[4 Sp][^F][Sft =][^G][4 Sp][^H][Inv] CALCULATOR [^H][Norm][4 Sp][^F][Sft =][^G]"
K I 240 POSITION 2,5
I H 250 ? "[Inv][^Q][^R][^E][4 Sp]Atari[7 Sp][Norm][^G] ^ Means to hold"
O L 260 ? "[Inv][Sft =]M[Sft =][Norm][14 Sp]0[Inv-sp] [^V] the CONTROL key"
O O 270 ? "[Inv][^A][^R][^D][16 Sp][Norm] [^V] and press the"
C J 280 ? "[Inv Sft =] [Inv Sft =][14 Sp]0[Inv-sp] [^V] next character."
A A 290 ? "[Inv][^Z][^R][^X][15 ^R] [Norm] [^V] [15 -]"
N M 300 ? "[Inv-sp]^Quit[Inv-sp]MC[Inv-sp]MR[Inv-sp]M-[Inv-sp]M+[Inv-sp] [^V] P Print [Inv]OFF[Norm]"
V K 310 ? "[19 Inv-sp] [^V]"
F S 320 ? "[Inv-sp] 0. [Inv-sp][Inv-sp]A[Inv-sp]B[Inv-sp]C[Inv-sp]D[Inv-sp]E[Inv-sp]F[Inv-sp] [^V] # Dec. places"
V O 330 ? "[19 Inv-sp] [^V]"
F H 340 ? "[Inv-sp]^Rt [Inv-sp][Inv-sp] % [Inv-sp]7[Inv-sp]8[Inv-sp]9[Inv-sp]/[Inv-sp] [^V] T +/-"
V S 350 ? "[19 Inv-sp] [^V]"
X L 360 ? "[Inv-sp]^Sqr[Inv-sp][Inv-sp]+/[Inv-sp]4[Inv-sp]5[Inv-sp]6[Inv-sp]X[Inv-sp] [^V]^C Memory Clear"
C Z 370 ? "[19 Inv-sp] [^V]^M Mem. to Main"
X O 380 ? "[Inv-sp]^Dec[Inv-sp][Inv-sp] Z [Inv-sp]1[Inv-sp]2[Inv-sp]3[Inv-sp]-[Inv-sp] [^V]^ Memory -"
F E 390 ? "[19 Inv-sp] [^V]^+ Memory +"
O X 400 ? "[Inv-sp]^Hex[Inv-sp][Inv-sp]CLR[Inv-sp]0[Inv-sp].[Inv-sp]=[Inv-sp]+[Inv-sp] [^V]"
J I 410 ? "[19 Inv-sp] [^V] Z Clear Current";
J U 420 ? "[^G][18 Sp][^G][^V]CLR Clear All"
Q I 430 ? "[19 ^M]";
D X 440 REM [Inv][3 *] GET 1st NUMBER [3 *][Norm]
W D 450 TRAP 440:TOTAL = 0:DISPLAY$ = "0":IF PRNT THEN LPRINT
W P 460 POSITION 3,8:? "[Inv Sft =]";CL$;"[Curs Lft]0"
Y G 470 GOSUB 890
P R 480 IF KEY=ASC("P") OR KEY=ASC("#") OR KEY=ASC("^C") THEN IN$ = "0"
Y I 490 IF KEY=ASC("^Q") THEN GRAPHICS 0:END
O V 500 IF LEN(IN$)=0 THEN 440
W Q 510 IF HEX THEN TOTAL = NUM
E L 520 IF HEX=0 THEN TOTAL = VAL(IN$)
A S 530 REM [Inv][3 *] OPERATION [3 *][Norm]
G M 540 TRAP 730:OP$ = " "
W A 550 IF KEY=ASC("+") THEN OP$ = "+"
Z U 560 IF KEY=ASC("-") THEN OP$ = "-"
    
```

```

DO 570 IF KEY=ASC("/") THEN OP$ = "/"
JL 580 IF KEY=ASC("*") OR KEY=ASC("X") THEN OP$ = "X"
DO 590 IF KEY=ASC("=") THEN OP$ = "="
KI 600 IF KEY=ASC("[^S]") THEN OP$ = "S":TOTAL = TOTAL*TOTAL
TS 610 IF KEY=ASC("[^R]") THEN OP$ = "R":TOTAL = SQR(TOTAL)
KW 620 IF KEY=ASC("[^H]") THEN OP$ = "H":GOSUB 1290:GOTO 760
XA 630 IF KEY=ASC("[^D]") THEN OP$ = "D":GOSUB 1430:GOTO 760
LA 640 IF KEY=ASC("[Tab]") OR KEY=ASC("[Sft-Tab]") THEN KEY = 0:OP$ = " "
WK 650 IF KEY=ASC("[Curs Lft]") THEN MEMTOTAL = MEMTOTAL+TOTAL:OP$ = "=":GOSUB 1220
YM 660 IF KEY=ASC("[Curs Up]") THEN MEMTOTAL = MEMTOTAL-TOTAL:OP$ = "=":GOSUB 1220
JO 670 IF KEY=ASC("[^C]") THEN MEMTOTAL = 0:OP$ = "=":GOSUB 1220
YD 680 IF KEY=ASC("P") THEN GOSUB 1760
YQ 690 IF KEY=ASC("T") THEN TOTAL = 0-TOTAL:OP$ = "="
OW 700 IF KEY=ASC("#") THEN GOSUB 1810
JS 710 IF KEY=ASC("%") THEN TOTAL = TOTAL/100:OP$ = "="
ZZ 720 IF OP$=" " THEN 440
PL 730 REM [Inv][3 *] GET 2nd NUMBER [3 *][Norm]
UM 740 DISPLAY$ = STR$(TOTAL)
US 750 IF PLACES THEN GOSUB 1540
GX 760 IF OP$="=" THEN GOSUB 1140
YJ 770 GOSUB 890
YJ 780 IF KEY=ASC("[^Q]") THEN GRAPHICS 0:END
TQ 790 IF LEN(IN$) THEN IF OP$="S" OR OP$="R" OR OP$=">" OR OP$="<" THEN 510
OX 800 IF LEN(IN$)=0 THEN 530
IK 810 NUM = VAL(IN$)
BO 820 IF OP$="=" THEN TOTAL = NUM
IS 830 REM [Inv][3 *] BASIC MATH ROUTINES [3 *][Norm]
MQ 840 IF OP$="+" THEN TOTAL = TOTAL+NUM
QE 850 IF OP$="-" THEN TOTAL = TOTAL-NUM
IB 860 IF OP$="X" THEN TOTAL = TOTAL*NUM
TU 870 IF OP$="/" THEN TOTAL = TOTAL/NUM
OY 880 GOTO 530
XM 890 REM [Inv][3 *] INPUT [3 *][Norm]
ZM 900 PLACE = 1
XU 910 IN$ = ""
BJ 920 HEX = 0
LG 930 GET #1,KEY
FM 940 IF KEY>127 THEN KEY = KEY-128:POKE 694,0
SQ 950 IF KEY>ASC("Z") THEN IF PEEK(702)<>64 THEN POKE 702,64:KEY = KEY-32
TX 960 IF KEY=ASC("Z") AND LEN(IN$) THEN POSITION 5,8:? CL$:"[Curs Lft]0":GOTO 890
VM 970 IF KEY=ASC("Z") THEN 930
ML 980 IF KEY=ASC(".") THEN 1030
QK 990 IF KEY=ASC("[^M]") THEN IN$ = STR$(MEMTOTAL):PLACE = LEN(IN$):GOTO 1040
PY 1000 IF IN$="" AND KEY=ASC("$") THEN HEX = 1:GOTO 1060
JW 1010 IF HEX THEN IF KEY>=ASC("A") AND KEY<=ASC("F") THEN 1030
CK 1020 IF KEY<ASC("0") OR KEY>ASC("9") THEN 1100
CW 1030 IN$(PLACE,PLACE) = CHR$(KEY)
WR 1040 PLACE = PLACE+1
VI 1050 IF PLACE>15 THEN PLACE = 15
UW 1060 IF HEX THEN DISPLAY$ = "$":DISPLAY$(2) = IN$
NS 1070 IF HEX=0 THEN DISPLAY$ = IN$
BA 1080 GOSUB 1160
SN 1090 GOTO 930
XG 1100 REM [Inv][3 *] RETURN FROM INPUT [3 *][Norm]
PR 1110 IF HEX THEN DISPLAY$ = IN$:GOSUB 1460:IN$ = STR$(NUM)
NZ 1120 IF LEN(IN$) THEN GOSUB 1140
AK 1130 RETURN
FB 1140 REM [Inv][3 *] PRINT NUMBER [3 *][Norm]
IR 1150 IF PRNT THEN GOSUB 1860
PD 1160 POSITION 3,8:? OP$
DI 1170 POSITION 5,8:? CL$
EB 1180 X = LEN(DISPLAY$)
CE 1190 POSITION 20-X,8
KF 1200 ? DISPLAY$
AG 1210 RETURN
VL 1220 REM [Inv][3 *] PRINT MEMORY [3 *][Norm]
MZ 1230 TEMP$ = STR$(MEMTOTAL)
BT 1240 POSITION 5,6:? CL$

```

```

C E 1250 X = LEN(TEMP$)
A J 1260 POSITION 20-X,6
W P 1270 ? TEMP$
B B 1280 RETURN
R V 1290 REM [Inv][3 *] DEC TO HEX [3 *][Norm]
M K 1300 IF TOTAL>=1000000000 THEN POSITION 5,8:? " Too Large! ":GOTO 1700
X V 1310 I = 9
C T 1320 NUM = TOTAL
W W 1330 HEX$ = CL$
X Q 1340 HEX$ = ""
X U 1350 X = NUM:NUM = INT(NUM/16)
Z A 1360 X = X-NUM*16
S C 1370 IF X<10 THEN HEX$(I,I) = STR$(X):GOTO 1390
L K 1380 HEX$(I,I) = CHR$(X-10+ASC("A"))
B M 1390 IF NUM<>0 THEN I = I-1:GOTO 1350
O F 1400 DISPLAY$ = "$"
C H 1410 DISPLAY$(2) = HEX$(I)
A N 1420 RETURN
K O 1430 REM [Inv][3 *] HEX TO DEC [3 *][Norm]
C Z 1440 GOSUB 1290
B T 1450 DISPLAY$ = HEX$(I)
Z V 1460 NUM = 0
A S 1470 FOR I = 1 TO LEN(DISPLAY$)
H B 1480 HEX$ = DISPLAY$(I,I)
Y V 1490 IF DISPLAY$(I,I)<="9" THEN NUM = NUM*16+VAL(HEX$):GOTO 1510
Q C 1500 NUM = NUM*16+ASC(HEX$)-ASC("A")+10
F C 1510 NEXT I
X Y 1520 DISPLAY$ = STR$(NUM)
A S 1530 RETURN
G Q 1540 REM [Inv][3 *] ADD .00 [3 *][Norm]
O Z 1550 IF HEX THEN RETURN
I W 1560 FOR I = 1 TO LEN(DISPLAY$):IF DISPLAY$(I,I)="E" THEN POP:GOTO 1690
F U 1570 NEXT I
A X 1580 FOR I = 1 TO LEN(DISPLAY$)
G W 1590 IF DISPLAY$(I,I)="." THEN POP:LOC = I:GOTO 1610
V N 1600 NEXT I:DISPLAY$(LEN(DISPLAY$)+1) = ".00":GOTO 1690
T H 1610 IF LEN(DISPLAY$)=LOC+2 THEN 1690
H N 1620 IF LEN(DISPLAY$)=LOC+1 THEN DISPLAY$(LOC+2) = "0":GOTO 1690
G R 1630 X = ASC(DISPLAY$(LOC+3)):X = X-48
E I 1640 IF X<=4 THEN DISPLAY$(LOC+3) = "":GOTO 1680
N E 1650 TEMP$ = DISPLAY$(LOC+1,LOC+2):X = VAL(TEMP$):X = X+1
R R 1660 IF X<10 THEN DISPLAY$(LOC+1) = "0":DISPLAY$(LOC+2) = STR$(X):GOTO 1680
C X 1670 DISPLAY$(LOC+1) = STR$(X)
N T 1680 TOTAL = VAL(DISPLAY$)
B M 1690 RETURN
Q W 1700 REM [Inv][3 *] PAUSE [3 *][Norm]
H M 1710 POKE 20,0
B X 1720 X = PEEK(20)
S X 1730 IF X<100 THEN 1720
M A 1740 POP
Q Y 1750 GOTO 440
V I 1760 REM [Inv][3 *] PRINTER ON/OFF [3 *][Norm]
B L 1770 PRNT = 1-PRNT
K E 1780 IF PRNT THEN POSITION 33,10:? "[Inv]ON[Norm] "
K B 1790 IF NOT PRNT THEN POSITION 33,10:? "[Inv]OFF[Norm]"
A P 1800 RETURN
E E 1810 REM [Inv][3 *] DECIMAL PLACES [3 *][Norm]
W G 1820 PLACES = 1-PLACES
W D 1830 IF PLACES THEN POSITION 3,12:? "0.00"
B I 1840 IF NOT PLACES THEN POSITION 3,12:? " 0. "
B E 1850 RETURN
W W 1860 REM [Inv][3 *] PRINT TO PRINTER [3 *][Norm]
N R 1870 IF PLACES THEN GOSUB 1540
C Z 1880 TEMP$ = OP$:TEMP$(2) = " ":TEMP$(3) = DISPLAY$:LPRINT TEMP$
B Q 1890 RETURN
I Y 1900 REM [Inv][3 *] KILL THE BREAK KEY [3 *][Norm]
Q V 1910 X = PEEK(16)-128:IF X THEN POKE 16,X:POKE 53774,X
A X 1920 RETURN

```

# Desk Top Publishing on a 130XE

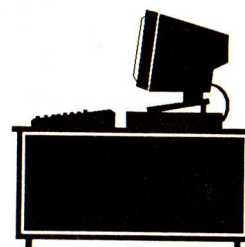

---

by G. L. Ray (TACE)

---

The newest and biggest application for the personal computer has to be desktop publishing. But, as of yet, the 8bit Atari has no versatile, user-friendly package that will create the type of product I expect from a DTP program. Sure, there is Newsroom and News Station and Type-setter. I have all of these programs, but they either are very limited in features, user friendliness or in print quality. My solution, therefore, was to combine features of several programs to achieve the results I wanted.

I teach 7th- and 8th-grade art in a junior high school. I assigned my 8th graders to produce a school newspaper as one project. We utilized two 130XE systems with Panasonic 1091i II printers. We used the computers to print out masters of the newspaper pages and then ran the paper off on school copy machines. The results may not be of laser printer and professional print quality, but the output was surprisingly good.

The software packages I used were varied and included professional as well as Public Domain programs.

The most utilized program I used was a word processor. Any word processor will work, providing it has the these options:

- ◆ Formatting commands to change margins, page lengths, etc.
- ◆ The ability to print double columns.
- ◆ A print preview feature to view the printout before sending it to the printer (Saves lots of paper!).
- ◆ The ability to print to a disk.

The word processor I use is the First X-Lent Word Processor, which has all of the above features and many more. All of the students' articles and submissions were first typed by the kids and saved to disk. I then proofread and helped the students correct their work.

The next step was to print the copy to disk, creating ASCII files which can be used by the Daisy Dot II Print processor. Daisy Dot II, a Shareware program by Roy Goldman, takes the ASCII file just created and enables you to print out your document in a wide variety of NLQ fonts. I have over 90 different NLQ fonts in almost any style to fit any application. I won't go into all of the features of Daisy Dot II, except to say it is worth many times the \$10 fee Mr. Goldman asks to register your copy.

Another program I used extensively is the Printshop from Broderbund. Printshop was used for illustrations and headlines. Some printouts were printed with Printshop directly to the final copy, while others were printed separately and pasted-up to the final copy with rubber cement.

We included crossword puzzles in our newspaper by utilizing Crossword Magic from Datasoft. First, I had the students make a wordlist and list of clues. Students then followed onscreen prompts to create and print their puzzles. I had the kids cut out and paste-up their puzzles and clues onto the final copy, created with the letterhead feature of Printshop. In this way, students could title and illustrate their puzzles with appropriate icons from various Printshop Library disks.

Another type of puzzle we used in the newspaper were WordFinds. We used a wordfind program written by Matthew

Ratcliff, published in the January 1984 issue of Antic. This program allows you make a WordFind puzzle anywhere from 10 to 30 letters square. It will then send it to a printer and even print out a solution, which we printed in the back of the paper. We also utilized the Printshop letterhead feature to do graphics and headlines. One of the best wordfinds was one which included the first name of every student in the junior high. We had to make two puzzles, and then paste them up side-by-side to get all of the names into a puzzle, but the results were impressive.

All in all, I was very pleased with our production. The project combined computer skills (Word Processing, Printshop, etc.) with traditional commercial art skills (Paste-Up, Freehand Cartoons and Illustrations). It was a very good educational experience, with results that the students could be very proud of.

I can't wait until next quarter. I have a new ST coming, along with a video digitizer so I can include student photos, etc. within the paper. But, as for the bulk of the work, we will still use my 130XEs, as the students are very comfortable with them, and they know how to use the software.

By the way, if you do not have Daisy Dot II, here is the address of Roy Goldman: 2440 S. Jasmine, Denver, CO 80222.

If you would like to order a disk packed full of Daisy Dot II fonts, or disks of Public Domain Printshop fonts, please send \$3 to cover duplication costs to G.L. Ray, Vice President, Tinker Atari Computer Enthusiasts, P.O. Box 668, McLoud, OK 74851.

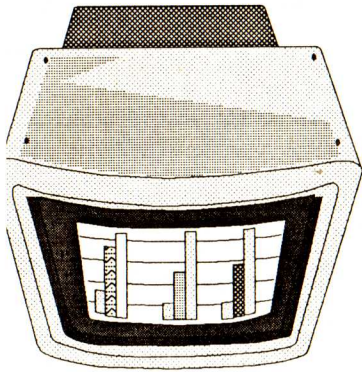

## A MULTISCAN MONITOR FOR THE ST

---

by LeRoy Valley (TAG)

---

The Atari ST has three resolutions — low (320 x 200), medium (640 x 200), and high (640 x 400). Low and medium resolutions support color and operate at 60 Hz. High res supports monochrome and operates at 70 Hz. Due to the difference in resolutions and screen refresh rates (60 Hz vs 70 Hz), Atari decided to offer two monitors. Unfortunately, the SM124 monochrome monitor ONLY supports high resolution, and the SC1224 color monitor ONLY supports low and medium!

Many users would like to have all three resolutions available. The color monitor is great for goodies like Spectrum 512 and games (we mustn't forget games!), and the monochrome monitor is excellent for desktop publishing, word processing and working on clip art.

Currently there are two ways to do this. You can either purchase both monitors or use a software package (like OmniRes) that emulates the resolutions that your monitor doesn't support. There are drawbacks to both methods. The first requires sufficient space for both monitors and a switch box (unless you'd rather plug and unplug cables each time you switch). The second is inexpensive and works, but high res on the color monitor is fuzzy at best, and low and medium res on the mono monitor lack color!

A third alternative has now been offered by Void Productions. Using their Synapse box (\$119), you can connect virtually any MultiScan (or MultiSync) monitor to your ST. A MultiScan monitor

is capable of automatically adjusting its refresh rate to that of the incoming signal, thus it can work equally well at 60 Hz or 70 Hz. This allows you to run ALL three resolutions on ONE monitor! Since most MultiScan monitors have resolutions in the 800 x 560 range, they are more than equal to the task of providing you with an image that is comparable to either of the Atari Monitors.

The Synapse is a multipurpose switch box (2" x 8" x 6") that controls your monitor(s) and your floppy drives. On the front of the Synapse are two push buttons labeled FLOPPY and MONITOR. FLOPPY allows you to switch between two disk drives, and MONITOR allows you to switch between mono and color modes. The Synapse is capable of acting as a monitor switch for the Atari monitors (similar to Monitor Master) as well as switching between modes on a MultiScan monitor.

Looking at the back of the Synapse, we find a variety of ports to plug goodies into. Ports available include:

- A 9 pin port to connect a MultiScan monitor.
- A VIDEO out jack that provides a sharp black and white picture in low and medium resolution.
- AUDIO out to connect to an external sound system.
- MONITOR IN.
- MONOCHROME monitor out.
- COLOR monitor out.
- FLOPPY IN.
- FLOPPY A out.
- FLOPPY B out.

Along with the Synapse, Void Productions also sells the Mitsubishi AUM1381-A Diamond Scan, a 14" MultiScan color monitor (\$525) with a built-in tilt and swivel base. (Note: you can also purchase the Diamond Scan directly from any of a number of distributors mentioned in Computer Shopper for about \$500. Keep in mind though, that Void Productions also gives you a cable.) The Diamond Scan offers a maximum resolution of 800 x 560, a .31 mm dot pitch, and the ability to scan up to 75 Hz. This enables it to handle the 70 Hz mono mode easily.

The first thing I noticed about the monitor was its SIZE. It's larger than the Atari monitor (about 2" in all three dimensions - HxWxD) and considerably heavier. Both Atari monitors have a 12" screen, thus the Diamond Scan offers 16% more screen!

Hooking up the monitor was a snap. Simply plug the ST monitor cable into the Synapse, then connect the monitor to the MultiScan port. The system booted up fine, but something seemed to be missing. I got it - no sound! Searching the monitor (and the manual) carefully, I discovered that the Diamond Scan monitor has no speaker!

I called Void Productions and talked to Dennis Sita (he's their technical guru). At this point I found that the people at Void are very helpful and knowledgeable. He informed me that he didn't know of any MultiScan monitors that had a speaker. (Now you know why the Synapse has an AUDIO OUT jack.) Oh well, I guess you can't have everything. I simply connected the Synapse to my stereo to rectify the problem.

I tested the monitor in color mode

first. The larger screen is impressive and compares well with (read: looks better than) the original JVC monitor from Atari. When comparing it with the current Goldstar monitors that Atari is shipping, there is no comparison!

A basic test I've always used on Atari color monitors is to run Spectrum 512, then look at the color palettes. On the old JVC monitors, the last of the color palettes (the smallest palette consisting of seven colors) is barely visible. Most of the newer Atari monitors (Goldstar) can't even display this palette! The Diamond Scan monitor displayed the last palette clearly, and Spectrum pictures looked gorgeous.

Pushing in the MONITOR button on the Synapse causes the ST to reboot (it triggers the mono detect line) and switch resolutions. The first thing I noticed is that mono mode was VERY impressive on a 14" screen! At this point I would like to note that the Diamond Scan is the ONLY monitor that offers automatic sizing between modes. Most other monitors would display a very small mono mode picture, requiring you to manually readjust the picture size.

The mono display is just as clear and sharp as the SM124. There is no discernible jitter or flicker, just a rock solid picture. In fact, I think it's better than the SM124. PageStream looks fantastic on this monitor when it covers the full screen! Spectre 128 users are going to love how well Mac screens look on a 14" screen.

In summary, if you really need access to all three resolutions,

then this is the way to go. The cost of the two Atari monitors and a switch box are about equal to the cost of a MultiScan monitor and a Synapse. (Of course, you do need some sort of sound system...)

If you don't plan on using a MultiScan monitor, the Synapse is still a good choice to use as a monitor and floppy switch box. And you can always add a MultiScan monitor later!

Void Productions has tested several monitors with the Synapse and those that work include:

- Imtec 1455N Mitsubishi Diamond Scan
- NEC II Samsung CN4551
- Sony 1390A Tatung 1495

Void Productions is constantly testing new monitors with the Synapse, so if you have any questions about a particular monitor, please call them.

Synapse \$119.00  
Diamond Scan 1455N \$525.00

Void Productions  
11400 Center Rd.  
Hayden Lake, Idaho 83835  
(208)772-0537



Unicorn Publications Presents....

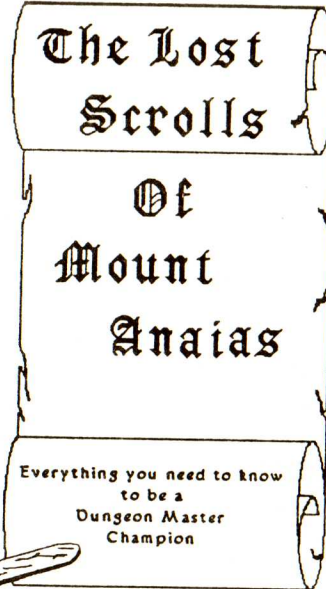

- Categorically Organized Spell List
- The Most Complete and Accurate Set of Maps Available Anywhere
- Level by Level Tour of the Dungeon
- Specific Solutions to the Many Puzzles
- Hints on Managing Your Party
- Roster of Champions and Their Attributes
- Original Illustrations
- Cross-Referenced Index
- General Hints and Tips Separated from In-depth Help
- Over 100 pages!

We've seen all other currently available Dungeon Master Hint Books, and all we can say is -- Don't Pay More and Settle for Less.

\$8.95 (plus \$1 postage and handling. COD orders available for an additional \$2)

Unicorn Publications  
3487 Braeburn Circle  
Ann Arbor, MI 48108  
Phone: (313) 973-8825

Dungeon Master is a Registered Trademark of Software Heroes, Inc.

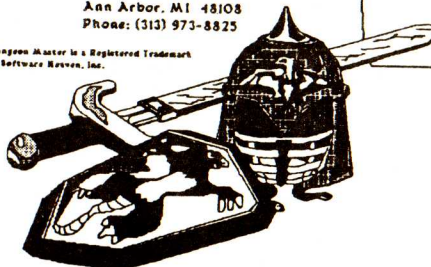



---

by **Donavan Vicha**

---

Program by Dirk Van Assche and Dan Van Agtmael \$79.95  
Copyright 1988 by Donovan Vicha

I've struggled with this animation/drawing program for close to three months so when the upgrade board on my new (pre-owned) 520ST went south, I took it as a sign that it's time to get this review written for better or worse.

GFA Artist is another import from Germany that seems to typify the German attitude toward GEM: avoid at all cost. The cost, however, in this country, is that users are left with a nonstandard interface for the program. Add to this their typical inadequate documentation due to translation difficulties and a glossary approach to describing functions and no tutorials concerning animation, and you have a program with a long, difficult learning curve.

This is really too bad, because GFA Artist contains some truly unique and unusual features that make it awfully appealing for creating animations.

Although it requires a full one-Meg/color setup to run, you can create animations of up to 2000 frames. The 1500-frame demo runs nearly four minutes, so quite a lot can be done on the Megs if all is compatible.

If you've got the time (or the understanding of computer animation from using other programs/computers) for trial-and-error learning, this is a program to investigate.

I would also like to comment that the

name of the program is misleading. The description on the box would lead you to believe that this program is similar to Spectrum and Quantum Paintbox, which are strictly paint programs that allow you to use many more colors than the ST was set up to provide.

The 1024 colors that you can use with GFA Artist are available in a cycling mode that can be used to rework D.E.G.A.S. and NeoChrome art files, but cannot be used outside of the main program -- there is no slide program for viewing your multi-color creations. While you can create NeoChrome and D.E.G.A.S. formatted files, the main features of this program emphasize animation. A more appropriate name would have been "GFA Animator" rather than "GFA Artist."

### **Awkward Interface and Inadequate Docs**

If this program had appeared for the Macintosh, it would have been condemned and left to collect dust on dealers' shelves. The ST community appears to be quite a bit more tolerant of programmers who don't bother following GEM protocols than Mac users who demand that all of their programs follow the same rules for using menus, dialog boxes and such.

There are quite a few ST programs that depart from the "standard" GEM protocols and several of those are very powerful and highly acclaimed programs (PageStream, WordPerfect and DEGAS Elite come immediately to mind). So there is hope for this program, I suppose.

GFA Artist opens to a screen with familiar rows of function boxes (icons) that give access to nearly 60 functions.

Although the icons are not all familiar, this looks at first glance to be something that can be worked out rather painlessly. But then using the icons proves not to be as straightforward as they first appear. To choose an icon, you must hold down the left mouse button (LMB) and slide through the three rows to the function you want. The icons are highlighted in this manner; it takes a click of the right mouse button (RMB) to activate your choice.

Now all this can be worked out eventually, but each time you've completed an action, you're returned to the icons. If you want to draw several boxes, circles or lines, you have to rechoose the icon after each item is drawn. Further complications to this process enter in when you decide to change the color of the tool you've chosen. To my mind, this arrangement is downright annoying and makes me resist wanting to get used to its interface.

A different set of commands is accessed for creating films. Both sets of commands can be brought forth using the F1 and F2 keys. The F1 functions are definitely more difficult to grasp due to the way in which this program handles putting together its animation sequences. The docs do a better job of covering this area, but are still incomplete in bringing about understanding to the novice user. More on the F1 commands later.

As mentioned already, the annoyance factor is heightened by the glossary format of the documentation. Each function is described adequately in a listing that follows the order of the icons as they appear in each row.

There is an index, so you can look them up easily enough, but there is

nothing written here that ties the functions together into something a novice user can understand. While there are appendices concerning creating a film, merging films and using the run-only interpreter (allowing you to distribute your animations without the main program), these are very mechanical descriptions that give little understanding of the program's animation functions.

Here's an example of the vague nature of the docs:

A GEM bit-blit function may be required because "in some cases it may be necessary for certain functions to operate at the highest possible speed." Which "certain" functions are they referring to here? The docs go on to state that "in general, we advise not to activate the GEM routine." Wouldn't it have been simpler and less mysterious to either state which functions really require this option or drop it, building the bit-blit routine into the functions that require it?

Finally, there is the unusual nature of this program's setup. You must boot this program without any accessories or other memory-resident programs — it uses all the bytes your system can spare. It is run in medium resolution, but only produces low resolution files.

To quit the program, you must power down your system in order to ensure that the memory is completely cleared. GFA Artist definitely takes liberties with TOS and GEM and must run on its own. One wonders if it will be able to run at all when the new ROMs become available for all STs.

### Exceptional 3D Effects and Other Features

If you plow through the program and play with its drawing commands, you quickly realize that whatever mistakes have been incurred with the interface and docs, the drawing capabilities are powerful and complete. Along with the usual drawing tools like lines, sprays, boxes, ellipses, cut/copy/paste, fills, arcs and such, there are some unusual features that stand out from anything offered by other paint programs.

Just about anything you can create with GFA Artist can be used as a paintbrush for maximum effect. Horizontal and vertical flips can be accomplished along with a combined flip, each with its own icon. Part of your picture can be bent vertically or horizontally to good effect as well. You can draw the shape of the bend or choose preset amplitudes of 1/2 Sinus, 1 Sinus or 2 Sinus (and are these terms correct? Sine?).

For more precise copy/cut functions, you can choose to "lasso" parts of your picture rather than the usual boxed rubber-band function. You can also capture a part of your screen to create globes, or vertical or horizontal parallelograms. You can rotate a captured part of your screen as well as create an animated rotation effect. If your shape is round or box-like, you can specify a number of sprites and create a zoom effect going from small to large or large to small — the number of sprites determines the number of stages in the overall smoothness of the transition.

The really impressive effects generated by this program follow a similar path. When initiating the animated version of the

following functions, you choose the number of sprites to be used (5–15 sprites seems to work well). You then outline the image to be transformed and then it can become a vertical or horizontal drum (cylinder shaped) or its perspective can be enhanced vertically or horizontally for a simple 3D effect, as an animated sequence. These effects can also be created in static, non-animated form. With a little trial and error, these are marvelous effects that can be instituted quickly and easily.

The drum effect turns your captured image into a cylinder-shaped object that you can size simply by moving the mouse, causing a wire-framed image of a cylinder to rotate and grow/shrink. If you're in the animated version, you also choose the placements around the drum where the sprites will occur — the more sprites used, the more detailed your "spin" will be.

I can envision how this drum can be rotated and stretched out across the bottom of the screen to create a moving roadway or a star map rolling over and over under the sprite of a spaceship. It's a terrific effect.

### Other Features

The two single-sided disks that come with this package include two proprietary fonts and a font editor program, the run-only interpreter that allows you to run your films independent of the main program, demo files for a demo film and a 1000-color demo screen. Also included is a film merger program that allows you to splice together parts of a film that is otherwise too big to run on a single-Meg ST.

The usual disk management commands can be accessed within the program to rename or copy files and format disks. NeoChrome color cycling is supported, and all popular color paint program formats are automatically loaded into GFA Artist for use as background screens for your film. Any resolution conversions needed to make the picture compatible with the GFA Artist format are automatically performed during the loading process.

You can use up to four different workscreens and easily move from one to another with one of the icon commands.

The F1 box commands are used to put your film together. These allow you to define a sequence of frames to be used, as well as other film editor functions for inserting, moving, copying and deleting frames from a sequence. You can load in up to four background pictures for use with your film. You can group sprites together to define their relationship as a single sprite, making them easier to handle in creating your film. You can call up sprites you've already created and saved and set up their sequences of movement. And you can take full control of each frame, creating layers for the various components of your file (e.g., background as layer 3, a tree in foreground layer 1 and a body walking between them as layer 2), setting start and finish frames and setting speeds. The default is 10 layers, so there is ample room for sprites to move around each other.

These functions are the real guts of the animation side of the program, and they seem very complete. Since you are going to



have to do a lot of trial and error just to see what kinds of effects can be created, I am happy to report the awkward interface is less of a problem with the F1 functions than with the 60 F2 icon set. But the docs really leave you out in the cold here.

Instead of such a vast amount of trial and error in figuring out special effects and film editing shortcuts, the docs should provide tutorials or checklists for achieving them.

**Conclusion**

I am not familiar with the Cyber Studio array of programs that are purportedly the state-of-the-art in animation software for the ST, nor with other animation programs like Aegis Animator or MichTron's Make It Move. I can make no comparisons as to ease-of-use factors among these programs and GFA Artist. I have seen animation films created with all of these programs, however, and the demo for GFA Artist is completely blown away by what I've seen done with Cyber Studio and Animator.

A lot of the effects that GFA Artist provides were not really used in the demo that comes with the package, so it may not be completely fair to write it off on this basis. I have not seen any other demos for GFA Artist, however, so there's nothing to show the real potential of this program.

I have to call this review a toss-up as far as any recommendations go. Computer animation is a complex process and requires detailed documentation that really communicates to the user, and the docs here fall short. The interface for using the splendid features of GFA Artist can be very annoying even when you get used to it. The wide range of colors provided by the program are of very limited utility, so this program fails as a paint program in spite of many unique drawing tools. In sum, GFA Artist is a disappointment.

*COMPUSCRIBE is the name for the Editorial and Design Services provided by Donovan Vicha, 7044 North Rockwell, Chicago, IL 60645. If you need help in writing, editing and/or producing professional documentation for your software, please send an introductory letter and he'll be glad to work with you for a reasonable fee. Donovan Vicha was a regular contributor to the now-defunct ST Applications magazine and is currently a staff columnist for ST X-Press magazine.*

**D & P COMPUTER**  
P. O. BOX 811  
ELYRIA, OHIO 44036  
(216) 926-3842

---

**Adaptec controllers** 4000MFM-~~\$119.95~~ 4070RL-~~\$144.95~~ 5500MFM-~~\$154.95~~

**Hard Drive Enclosure** - Desktop style. Holds 2 half height drives or one full height. Fan, On/Off Indicator Light. Full 60 Watt power supply. **\$119.95**

**Hard Drive Kit** - ICD Host, controller, above enclosure, all cables, brackets. You provide drive **\$235 SCSI \$365 MFM \$390 RLL**

<b>ICD or SUPRA host adaptor</b> \$99.99	<b>IMG Scan</b> (Seymour Radix) \$79.99
Supra FD-10 10meg floppy \$875.00 Supra 40meg (mega internal unit) \$799.00	<b>Supra 2400bd modem \$129</b> w/RS232 cable for \$136  <b>1 YEAR WARRANTY</b>
<b>Tilt Monitor Stand/Power Center</b> \$54.95 <small>5 individually switched outlets with EMI/RFI surge protection</small>	<b>MODEM SPECIAL</b> 2400bd Hayes compatible \$119 w/RS232 cable \$125 <b>5 YEAR WARRANTY</b>

**Call For Free Catalog**

<b>PCM FD-1 Double Sided Drive</b> \$169.95 	<b>Sony Boxed 3 1/2" disks</b> Single Sided - \$12.99 Double Sided - \$16.99
<b>STAR NX-1000 MULTI-FONT</b> 144cps draft - 36cps NLO 8 built in fonts \$189.99 	<b>Hewlett Packard</b> <b>DeskJet Printer</b> 300 DPI \$749.99 

(312) MARS-INC  
312/627-7462

10418 E. St. Charles Rd. Lombard, IL 60148-2069

<b>MALP - Martian Atari Light Gun</b> . . . . \$39.95 Light Gun Cartridges \$31.95 ea. 2 for \$59.95 Barnyard Blaster Crime Busters Crossbow	Atari 8bit <b>DIAMOND OS</b> w/Paint & Prog. kit \$61.95
<b>ST STUFF</b> F-16 Combat Pilot \$37.50 Real Ghostbuster \$33.50 Mad Flunky \$33.50 Freedom \$33.50 Operation Neptune \$37.50 Fusion \$call Personal Nightmares \$call	<b>ST STUFF</b> Nickelodeon Five \$19.95 2nd Speaker Adapter \$21.95 Nine Lives+ Dk \$4.95 (unlimited lives/fuel for: Batman, Live & Let Die, Baal, Garfield, Zynaps, Operation Wolf, Bubble Bobble, Space Harrier)
<p style="text-align: center;"><b>NEW &amp; COMING</b></p> The Great Diamond Caper (Raffles) \$33.50 Airborne Ranger \$call Operation Hormutz \$call Monday Squad \$call Chicago 1930 \$call Airborne Ranger \$call	
<p style="text-align: center;"><b>SPECIALS</b></p> Blasteroids \$29.95 Elemental \$33.50 R-TYPE \$27.50 Storm Trooper \$37.50	

# For 520ST, 1040ST, 520STfm and MEGA MEMORY: EXPANDABLE Hard Drive Kits:

Expand your St's memory to ONE Megabyte, TWO and ONE-HALF Megabytes or even FOUR Megabytes with the tech-specialities plug-in memory modules. All memory boards fit under the R/F shield. The CPU is completely available for any future enhancements (blitter, coprocessors, speedup kits etc.). No soldering is required.

520ST modules use 256K DRAMs for upgrades to 1 MB and 1 Megabit DIPs for 2-1/2 and 4 MB upgrades. All boards are fully socketed and the expandable boards can be configured for either 256K or 1 Mb chips. This means that you can start by upgrading your 520 to one Megabyte and later move up to either 2.5 or even 4 Megabytes--the maximum for any ST, even the Mega! Installation is completely solder-free. Comes with detailed illustrated instructions and a one (1) year limited warranty.

Upgrade your 1040ST or 520STfm just as easily as a 520ST! Send us your 520STfm and we will install the second bank of memory complete for only \$269 plus shipping. Or install one of our 1040 memory boards and upgrade your ST to 2-1/2 or even 4 Megabytes.

Limited space above the 1040 mother board prohibits the use of conventional sockets in one bank. Optional "ZERO Height" sockets allow you to have this bank socketed too, so you can plug in or exchange the expensive 1 Mbit chips. The "ZERO-Height" socket kit is also available separately so you can install it at any time!

520A: Socketed, no RAM	\$ 129
520B: 1 MB, socketed	\$ 249
520C: 2.5 MB, socketed	\$ 495
520D: 4 MB	\$ 795
520-1: 1 MB, non-expandable	\$ 199
1040A: 1 Bank sockets, no RAM	\$ 110
1040B: Fully socketed, no RAM	\$ 149
1040C: 2.5 MB + 1 bank sockets	\$ 495
1040D: 4 MB	\$ 795
1040K: Kit w/all parts, no RAM	\$ 68

Clock Option on Memory Board \$ 30  
Clock, stand-alone for 520/1040 \$ 38

We ship COD (\$3) or prepaid, sorry no credit cards!  
Add the following amounts for shipping and handling:  
memory upgrades - host adapters: 1st unit \$5, add. u. \$2  
hard drive kits/CPU cases without drive \$10/20, h. d. kits with  
drive need special shock resistant packaging \$20/30  
Texas residents add 8% state sales tax.

Above prices correct on 3-22-88. Prices of populated boards  
subject to chip adjustments to meet fluctuating DRAM prices.

520ST, 1040ST, 520STfm and MEGA are trademarks of  
ATARI Corp.

All kits come complete with software and **all** parts needed to get the system **operational**, 1 year ltd. warranty. There are right now four different case styles available:

1. 10" wide x 6.8" high x 15" deep (desktop) with full SCSI interface and 'DMA-through' connector  
-150 W PC power supply with fan  
-room for up to 5 half-ht hard drives or combination - full/half height  
-mounts on floor, under desk or on desktop  
-can power up 520ST and external floppy drives.  
-optional delay circuit for CPU allows fully automatic power-up!

No Drive--Install your own - \$385  
10 MB - \$485 30 MB RLL - \$695  
20MB 48 ms - \$595 40 MB ST251 \$795  
30 MB f. ht. 45 ms autop. CDC - \$745

2. 13.25" wide (same as MEGA) x 15" deep x 3.8" high with full SCSI/DMA through host adapter  
-ready for up to 3 1/2 ht or 1 each full/half ht. hard/tape/floppy drives  
-55 W power supply with 115V-fan  
-can be placed under monitor

No Drives--Install your own \$295  
10 MB - \$395 30 MB CDC - \$565  
20 MB 48 ms - \$525 40 MB ST251 \$745  
65 MB 22 ms autopark RLL drive \$845

3. 4.5" wide x 6" high x 13" deep with single port host adapter  
-ready for 2 1/2 height or 1 full height drive  
-55 W power supply  
-optional fan available (add \$18)  
No Drives--Install your own \$249

10 MB - \$349 30 MB RLL 48ms - \$570  
20 MB - \$485 40 MB ST251 - \$645  
63 MB h. ht. 22 ms auto parking - \$795

4. CPU CASE, 18" wide x 12" deep x 8" high.

Upgrade your 520/1040 to the MEGA standard, separate CPU and keyboard, gain space for 3 each 3.5" and 5.25" half height floppy and/or hard drives in two separate drive bays.

\* 150 W power supply with inbuilt fan supplies power for all possible combinations and keeps everything cool.

\* a reset button on the keyboard makes a warm reset easy.

\* an adjustable circuit delays the CPU on power up, allowing a totally automatic bootup.

\* Your monitor can be switched on or off automatically, using an optional cable - complete **One** switch operation for the whole system is possible

\* The plane immediately above the ATARI motherboard is reserved for future expansion. A 68020/68881-2 coprocessor board with sockets for up to 8 MB of high speed 32 bit memory is currently being developed.

Kit contains all parts for standard 520ST/1040ST/520STfm, please specify machine type - \$295

Hard Drive kits for CPU case:  
10 MB - \$295 20 MB 48ms - \$398  
30 MB full ht. CDC 45 ms - \$465  
Please note that you get back about half of the CPU case costs after buying a Hard Drive Kit.

Host adapter cards are also separately available and come with software, either bare or with case and 6' long round shielded SCSI cable with embedded power supply lines. Up to 20' cable length and additional connectors, made to order available!

Two different types are available, both are full SCSI versions with DMA through connector, the higher priced one has also a real time clock.

Prices after the "/" are for host adapters with cas/cable..

\$79/119 with clock - \$119/159

Space limitations don't allow a more detailed description. For complete catalog contact:

**tech-specialities Co.**  
909 Crosstimbers, Houston TX 77022  
(713)691-4527/8 FAX: (713)691-7009

Distributors for:

Australia  
Tech-Soft, 460 Stirling Hwy, Suite 37  
Claremont, Western Australia 6011  
Tel.: (09) 385-1765

Canada (East)  
Computer Country, Paul Wilson  
148 Waterloo Street, Stratford, Ont., N5A  
4B4, Tel.: (519) 273-1011

West Germany  
ING.-B. Dipl. Ing. M. Krompasky  
Schillerring 19, 8751 Grosswallstadt  
Tel.: (06022) 24405



Cascades Atari Computer Enthusiasts (CACE) is the Atari club in and around the Jackson County area. The main purpose of the club is to help inform new users and to promote the use of Atari computers in the community.

President	Brent Fisher	764-4599
Vice-President	Tim Hotchkiss	522-8912
Secretary	Joe Cripps	782-0199
Treasurer	Craig Schaff	787-3970

The current membership dues are \$10 per year, or \$14.80 if you wish to subscribe to Atari Interface Magazine, and are payable at any of the CACE monthly meetings, or by mail. Club membership includes access to the entire club software and publication libraries, along with a monthly published newsletter. Any written communication with CACE or payments by mail should be sent to: CACE, P.O. Box 6161, Jackson, MI 49204. Our meetings are held on the second Sunday of the month, from 1 pm to approx. 4 pm. The meetings take place at the East Side Lounge, on the corner of Horton and Gansom Streets in Jackson, MI.

#### Fishin' Around by Brent Fisher

This month I predict that Tim Sharpe will predict that I will predict that we will predict that predictions will take place this month. I realize that this would have been a perfect April fool's column but as you might have guessed I am writing this in April so it counts (sortof?). Anyway, on with my past and not so future predictions that really came true.

—First I predict Michigan will not only play Seton Hall for the NCAA Men's Basketball Championship but that they will win by one point — how's that for a great prediction. So now all of you who know a bookie tell him Brent sent you.

—Next, I think that the Columbian coffee supertanker, the Juan Valdez, will spill more than 10 million gallons of coffee into the Pacific ocean causing sealife and divers in the area to become stressed out and hyperactive. Now you've heard it, just don't tell Exxon.

—I also foresee a new music recording label emerging called AMS or Atari Musicians Syndicate. After all, they are going to need one if Atari keeps booking all of this major talent for their computer shows. In fact, they might even need a new slogan like "Atari and music, can you believe it?" Maybe, but I don't know.

Had enough of these predictions? Ok, ok. I get the point, but you have to admit it was kind of fun anyway. One prediction that I had made in the past was that Jimmie Boyce's Atari Writer+ column would be done and ready to send to Unicorn Publications. This has come true and the articles will be sent as soon as I get all of the material from Jim.

It looks like both of the Atari shows scheduled for Michigan are going to be huge successes for all involved — especially the users who attend the shows. You probably will be reading this after the MACE show but hopefully before the World of Atari one.

Another thing of importance I should mention is that I probably won't be at the next meeting because of contractual complications, i.e. I am going to be working, but if there is a way, I'll

be at the meeting. Since I'm on the subject the next meeting will take place on Sunday May 14, at 1 pm.

One unfortunate piece of news that I should pass along is: A couple of months ago AIM ran an article that stated Atari was allowing users to send in their old equipment, namely 1050 disk drives and Atari would send back a brand new XF551 in its place. Well, it seems Atari still has a back stock of 1050s so if you send one in you will probably receive one in its place. But don't despair, if you call Atari it is possible they will run out of the old drives in the future.

Those of you who happen to be reading this in our old newsletter will notice that the newsletter has changed a bit in its format. I hope you like it. James Tackett has agreed to publish and layout the newsletter using a program that he did himself. Those of you at the last meeting I am certain will agree and everyone there did that this is a much better way to go. Those of you at the magazines that we send this to every month, if you are interested in more information, just contact us at the above address and we will see what we can do for you.

Some of you may or may not have noticed that Jimmie Boyce is no longer editing this fine publication. He has dropped from the post so that he can devote more time to his family and so that he can use his computer for more productive things. Just remember Jimmie, I still have the high score on Mirax Force.

For this month this is Brent Fisher signing off, and I should like to have all of you who even glance at this come to the meeting.

## ProCopy <sup>ST</sup> BACKUP UTILITY

You can't backup your software because copy protection locks you out. **ProCopy** is the key!

- Protects against the accidental loss of expensive software
- Works with all Atari STs
- Copies both S/S & D/S disks
- Use with 1 or 2 disk drives
- Not copy protected
- **FREE** shipping and handling
- **TOLL-FREE** telephone number
- Updates are only \$12 with return
- Orders shipped same day
- Disk analyze function included

and C.O.D. orders

\$ 34.95

**Call (800) 843-1223**

Send check for \$34.95 (overseas add \$2.00 for air mail) to:

### PROCO PRODUCTS

P.O. BOX 665, CHEPACHET, RHODE ISLAND 02814 USA  
(401) 568-8459

<b>Available Internationally in Europe and Australasia</b>	<b>THE MOVING FINGER CO.</b> Building 2 Shamrock Quay Southampton, SO1-1QL England Tel. 0703-229041	<b>TECH-SOFT COMPUTER WHOLESALE</b> 324 Stirling Highway Claremont Western Australia 6010 Tel. 09-385-1885
--	--	--

**Dealer Inquiries Welcome**



CHAOS is the Capitol Hill Atari Owner's Society, serving the Atari community of the Lansing, Michigan area. The Campus Hill Atari Owner's Society is the Michigan State University chapter of CHAOS.

Membership dues are \$15.00 per year and entitles members to a 1-year subscription to the Atari Interface Magazine, a free disk from our regular library, and access to our libraries and other resources. Dues may be paid at any CHAOS meeting or by mail. If not using an official membership application, please include your name, address, phone and a list of your equipment and interests.

Sysop John Nagy and CHAOS invite you to call one of the country's finest BBSes at 517-371-1106, 300/1200/2400 baud, 24 hours a day (Atascii/Ascii) serving both 8 and 16 bit Atari computers. Send inquiries regarding CHAOS, mail orders, memberships and so on, to: CHAOS, PO Box 16132, Lansing, MI 48901.

General meetings of the membership take place several times a year. 8bit and 16bit Special Interest Group meetings take place monthly. The S.T. Interest Group meets on the second Saturday of the month. The 8bit S.I.G. meeting, for 400/800 and XL/XE owners, takes place on the third Saturday of the month. Meetings begin at 10 a.m. sharp and last until 1 p.m.. Members and guests are welcome to any SIG meeting that interests them.

Illegal copying, or any violation of copyright laws, is not condoned or allowed at any CHAOS-sponsored function, including the club BBS.

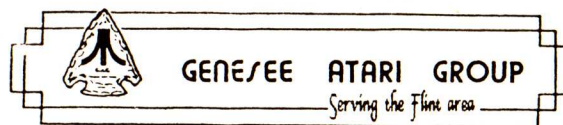

The Genesee Atari Group is a non-profit group of Atari owners in and around Flint, Michigan. Our purpose is to provide assistance to users of Atari personal computers. This organization is not affiliated with Atari, Inc.

GAG meets on the second Wednesday of the month at the Neithercut school, located at 2818 Crestbrook Drive, Flint. (Off Atherton between Hammerberg and Van Slyke). Meetings begin at 6:30 pm. All are welcome. GAG is a participating member of the Atari Interface Magazine, and members can purchase subscriptions at a greatly reduced rate. GAG is also affiliated with the Great Lakes Atari Digest, and members receive a free subscription with their membership. Membership is \$15 per year for the family.

GAG has an exceptional public domain library of 8- and 16-bit software. Contact one of the officers to receive a complete catalog. GAG also has a large magazine library for use by it's members, including Antic, Analog, ST-Log, Start, and several others. We do not support piracy. Piracy is theft!

For more information contact:

The Genesee Atari Group PO Box E Flint, MI 48507

Jerry Cross	President	736-4544
Dave Pettit	Vice Pres.	232-0508
Ed Kalush	Librarian	517-288-4531
Gil Merciez	Librarian	
FACTSBBS		736-3920

### President's Corner by Leo Sell

Writing for the future is always a challenge. No less so this month. By the time you read this, the Michigan Atari Computer Expo, sponsored by MACE, will have taken place. Congratulations to MACE for a successful show. And many thanks to the officers of MACE for their hard work in bringing the various vendors and their great deals to us here in Michigan.

We're now looking forward to a different style of show - the World of Atari show coming up on June 24 and 25 at the Dearborn Hyatt Regency, sponsored by ST World. The World show is the second large Atari exposition in a continuing series of shows taking place around the country. The first was held April 22 and 23 at the Disneyland Hotel in Anaheim California. Most national Atari vendors and developers were there, many of them announcing and displaying their newest products and offerings. For instance, both the GCR cartridge and the PC Ditto II were expected. Chances are good that most of the same vendors will be at the Detroit World of Atari show. Make sure you're there to see the best, brightest, and newest offerings in all Atari computers including the 2600, 800/XL/XE and Game System, and the ST and Megas.

Along with major Atari developers and vendors, we expect Atari at the World show. CHAOS, GAG, MAGIC, and GLASS are participating as sponsoring clubs and will be at the show as vendors. Other clubs can make arrangements to be there at a club section. These shows are causing major excitement in Atari circles across the country. You won't want to miss it.

Happy Atari-ing!

Last month I received a call from Dennis Shingledecker from Oscoda, Michigan. It seems there are a number of folks in his area who are Atari fans, mostly from the nearby Air Force base. Because the members are always on the move, it was hard for them to keep a regular user group active. So he asked if it would be possible to start up a "branch" of GAG in his area. After discussing it at last month's meeting, the members gave the go-ahead. The Oscoda group will meet on the 2nd Wednesday of each month at Dennis's house, located at 4766 Interlake. Arrangements are being made to use a building on the Air Force Base, and details will be given out later. For more information, call Dennis at 739-4434. They now have a copy of the entire GAG library for their use. Welcome to the club!

My thanks to Randy Ferrier for his MIDI demo at the last meeting. This month's newsletter contains the first (I hope) of many MIDI articles by Randy. It should have been in last month's, but I somehow botched up and never sent it in to the editors. Sorry again Randy.

A final reminder that we need volunteers to help out at the World of Atari show on June 24-25. I was a little distressed at the lack of participation for the MACE show, and I hope you can fit a few hours into your busy summer schedule. We also would like to borrow your computer to loan to the vendors. If you can help out call Jerry Cross at 313-736-4544.

That's all for now, see you at the next meeting.



GKAUG meets on the second Saturday of each month at 11 a.m. in the Dewing Hall, Room 305, on the Kalamazoo College Campus, corner of Academy and Monroe. Dues are \$25/yr and include a subscription to Atari Interface Magazine.

President	Frank Fellheimer	657-6106
Vice President	Dan Youngs	
Treasurer	Dave Bryant	
Archiver	Dave Oldenburg	
SysOp	Alex Stevens	
GKAUG BBS		(616) 657-2665

Our April meeting went off without a hitch... except for the fact that we were missing the disk drive to do our demo of "Cheat" by Alpha Systems. I blame it all on our Archiver, who was more interested in making an extra buck than attending our all important GKAUG meeting... and he forgot the drive too! We spent the rest of the meeting discussing some "secret tips" on Donkey Kong Jr., Ghostbusters, Preppie and Caverns of Mars... Yes, we still play some of these.

I figured that more people would have been out to the meeting, but they weren't. Only about six of us this time. If it keeps up, we will end up with only those people that are really serious about working with the ATARI computer, and we won't need a scheduled meeting for that. We had two ST users at the meeting, but No ST. It looks as if there is no one available now to organize them. We will provide the forum for operation, but you users will have to get together.

Next month, 13 May 89 we will try to discuss new hours of operation, you need only let me know your thoughts on this and they will be considered. We are always able to change things a bit. We will also be doing a demo of "Cheat"... I finally made it through Shamus Case II using it. I also have the Version 1.2 of the Converter. We can look at that too.

We welcome Bill Berner as the new Librarian, he will be the one to contact in the event you need something from the library. Dale Vincent is working on a new career in Florida. We wish him the very best in his endeavors. We are still looking for someone to take the Treasurers job. Bryant has done a great job for some time now and has other activities he needs to complete. Call me, its not hard. Frank

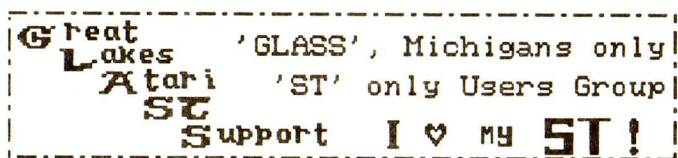

Meetings - First Thrusday every month, 6 p.m. to 9:30 p.m., Athens High School, 4333 John R, Troy, Mi., 1/10 north of Wattles <17 Mile> - Room 1528 - Mailing Address - P.O. Box 99737, Troy, Mi. 48098 Phone - (313) 828-1653 after 4 p.m. - Steve Mileski, president

Dues - \$1.00 per month, ie:join in April - pay \$9.00, all memberships expire on January 1, each year. Non-members welcome at no charge.



Next Meeting: 6:30 P.M. Wednesday, 7 June 1989. Wyoming Public Library. 3350 Michael S.W.

Tim Feenstra	President	(616)784-6230
5625 Buthview N.E.	Comstock Park, Mi. 49321	
Greg Williams	Vice President	(616)698-7319
George Nosky	Treasurer	(616)942-1527
Bob Bulliment	Secretary	(616)457-1766
Chuck Baughman	Librarian	(616)795-7373
Terry Reine	Membership	(616)698-7244
Gary Heitz	Director	(616)676-0112
Gerry Borysiak	Director	(616)896-9358
Charlene Bird	Director	(616)795-3593

**President's Monthly: 17 April, 1989**

With this column, we are now going to include the minutes from the last meeting for those who did not get to attend for some reason or another.

Another first is the inclusion of the calculator that Gary Heitz finished. It sure looks like a calculator, and from the use I gave it this past weekend, it works like a calculator too. Good work Gary. US doublers are available on a first come, first served basis until we run out. If you missed the May meeting, contact me and see if there are any left.

Well the weather is getting warmer. To those not attending the meetings this summer, I wish a warm one (not too warm), and to those who find time for their 8bit, see you at the meetings. One more thing. I have just received the new COM file for Textpro 3.2, which is made to work very, very well with SpartaDOS. Keep an eye on your favorite BBS for it in your area.

**Meeting Minutes**

Tim opened the meeting discussing the Michigan Atari Computer Expo to be held May 6 & 7 in Romulus. Tickets are available through the club, and I posted a message on E.T.X.E. BBS for anyone interested in carpooling to the fair.

Tim announced another deal thru ICD. They are offering US Doubler chips for the 1050 disc drive for \$20, a pretty good deal. Gary Heitz finished programming and showing the calculator program. Some of the functions include printing to printer, % functions, sign changing, error trap, and disabling the break key. Really a sharp program. Thanks Gary!!

Chuck noted that the Kermit program (VT-100 emulation) is now in our library. A demo of MACH-DOS (which is in our library) was done by Tim along with the Desktop program from the ETXE BBS. Both would be a good addition to any home computing library.

The GRASS electronic questionnaire program was shown and everyone should complete their data on this disk to update the club's records. Next month we will have a demo of the ETXE BBS via VCR, along with a modem to be raffled off. Don't miss the May meeting!!

See you next month,

Bob Bulliment



Michigan Atari Computer Enthusiast members receive, as part of their dues, Atari Interface Magazine, a monthly magazine keeping them informed of what is new in MACE and the whole Atari community. Members are also entitled to purchase disks from the 8bit and ST public domain software libraries. 8bit disks are \$3 each and ST disks are \$4 each, and if you buy three disks from either library and you can choose a 4th disk absolutely FREE! Non-members may purchase disks at a slightly higher rate. Mail order is also available. For a catalog of current disks in our libraries, send \$2 for either an ST or 8bit catalog to the MACE address below. Please indicate ST or 8bit when sending in your order.

The most important benefit you receive is the help and support from (and interaction with) other Atari owners. If you're having a problem, need advice about a software package or whatever, your fellow MACE members can and will help. That's what a user group is all about -- helping each other get the most from our computing.

MACE meets on the third Tuesday of each month from 7:30 to 10 pm in Room 115 of the Southfield Civic Center at 10-1/2 Mile and Evergreen Roads.

MACE can be contacted at PO Box 2785, Southfield, MI, 48037 or by calling Bill Rayl at (313) 973-8825 or Bob Retelle at (313) 483-7358.

Any MACE member who contributes an article which appears in Atari Interface Magazine is entitled to a free disk from the library of his/her choice.

#### MACE BBS Numbers:

MACE WeST	(313)582-0657	(3/12/2400)
MACE East	(313)978-1685	(3/1200)
The College Board	(313)478-9647	(3/12/2400)
DownRiver Outpost	(313)675-4660	(3/12/2400)
Molin's Den	(313)420-0407	(3/1200)

### March General Meeting Minutes

The March general meeting of MACE was called to order by Meeting Coordinator Bob Retelle at 7:45pm on Tuesday, 3/21. Bob displayed some of the graphic demo disks from the ST Library (Robb's "Little Computer Demo") and some programs from the 8bit library including Prism Magazine and Air & Sea Patrol.

Bob also noted that copies of DOS XE from Atari are now available in the club disk library, courtesy of Atari Corp., and copies of the manual may be ordered by sending \$13.50 to Atari Corp.

President Bill Rayl discussed the continuing effort to execute the MACE Atari Show, to be held in May. Many of the Michigan user groups are now planning to attend, and the list of vendors is growing rapidly to the point where much of the floor space is already committed. Bill noted that no money has yet been taken from the club treasury, and further noted that Sig Hartmann of Atari has stated "Atari WILL be at both shows..." referring also to the upcoming ST World of Atari show in June. Some of the vendors who are already committed to attend: ICD, Alpha Systems, Microdaft, Innovative Concepts, Mars Merchandising, Total Control Systems. Also, Derrick Mihocka (ST X-Former) and Robert Puff (8Bit ARC, DiskCom3) are planning to attend and display their wares.

Bill then fielded questions from the membership about additional details and specifics. Pattie then continued the discussion

and asked the persons interested in working at the show contact her after the meeting to be put on the schedule, thus qualifying them for the "gold card" program (a bonus discount from normal show prices at the various vendor booths during the show.)

Bill then discussed some of the currently available templates for use with popular spread sheet programs that aid the user in performing calculations for the '88 tax year. Mike Olin briefly discussed The Tax Advantage by Double Eagle Software, and made a copy available for interested members to play with after the meeting.

After a brief intermission, Bill and Bob discussed current news in the Atari world. Bob talked about a Sinclair Spectrum emulator for the ST that is currently available in Europe. This emulator performs true multi-tasking, and can run an IBM emulator. There was also some lighter discussion regarding lawsuits between Apple Computer, Apple Corps and Macintosh Labs.

April Minutes — The April meeting of MACE was held 4/18/89 at the Southfield Civic Center. The meeting was called to order by President Bill Rayl who spoke briefly about what's new in Atariland. The most popular news is the pending release of the sequel to Dungeon Master, but the room fell silent when Bill announced that United Computer had gone out of business. (Even Ed and Todd were quiet for a moment... MOST unusual!) Probably some of the most significant news lies in Cindy Claveran's disappearance from the Atari lineup.

Bill proceeded to demonstrate PageStream, announcing the package he was using would be raffled at the end of the meeting. Bill showed some of the tricks and tips that make this program fun and easy to use. Brian Cassidy, of Windsor WAUG fame, walked away smiling as several people attempted to suggest he'd NEVER get commercial software past Customs on his return trip and that he should consider their \$10 offers to sell.

Convention Coordinator Pattie Rayl led a discussion about the upcoming MACE Atari Show. Using PageStream to show some of the forms and paperwork she has used to-date, Pattie gave a detailed description of where the various vendors would be located in the main room, followed by a similar description of the secondary room that will "house" additional vendors. Many doorprizes are planned including disks, holders, software and even a 520STfm system. Pattie then fielded questions from the members, made a plea for persons to help at the show AS WELL AS at the MACE booth, and then distributed flyers/maps showing how to get to the Hilton Inn at Metro Airport.

After a brief intermission, 8bit Librarian Ted Newkumet demonstrated the MACE New User Disk, a compilation of various "necessity" software (word processor, DOS hints and tips, and the like...) for new members which includes a ton of Help files. The disk is completely auto-booting and well thought-out.

The next meeting of MACE will be held on May 16th, which will feature the annual MACE Birthday Party, so make plans now to attend and help MACE celebrate its EIGHTH (!) year of service to the Michigan Atari community.

Michael Olin MACE Rec. Sec'y

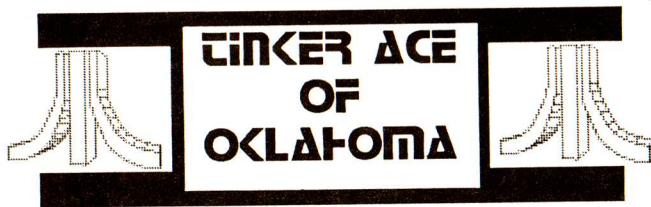

TACE -- Tinker ACE of Oklahoma meets the first Saturday of each month at 1pm (12:30 set up time) in the Moore Public Library, 225 South Howard, just off of SW4th and I-35 in Moore. TACE can be contacted at PO Box 7697, Moore, OK 73153 or at the TACE BBS (405) 793-7980, 24hours., 3/12/2400 baud, running Oasis 4.3 software with over 60megs of online storage, ST & 8bit support. Dues: Full - \$20.00, Correspondence - \$15.00.

President	Michael Beard	(405) 793-7978
Vice President	Greg Ray	(405) 964-3765
Sec/Treasurer	Stephen Moffitt	(405) 732-8449
Librarian	Greg Yelle	(405) 390-9184
BBS SysOp	Michael Beard	(405) 793-7978
Technical Advisor	Ron Hamilton	(405) 387-5649

### The View from HQ. by Michael Beard

The BBS was transferred to Rick Spencer's house on the 12th of April. Until the 10th of May, the old number is forwarding all calls to the new number which is (405) 755-9561.

Speaking of training, I will not be running for any office next year in the TACE club. I sincerely hope that the members of the club to come to the aid of their club at election time, which is coming up soon. The July meeting is the date for elections. I will remain a member of TACE, as I feel it is one of the best clubs around. What with the over 60meg BBS, and the best newsletter of any club in Oklahoma, why not stay a member? As for the new Officers, it's up to you folks!

### Secretary Report by Stephen Moffit (CIS 75006,2204)

Happy April Fool's day! Not much happened at the meeting this month. We did learn that Michael Beard will most likely have to give up the "Sysop-ership" of the TACE BBS, and as such the number will be changing. It should remain within the local dialing area (a rather large area, anyways). (Note: The new number is (405) 755-9561). The reasons for the change are many, but the main one is Michael Beard is moving on Base (Tinker) and cannot afford to move the board on the base with him.

Some replacement springs for the ST's keyboard was sent to the President recently -- they are meant to give the keyboard the feel of the newer Mega STs. These springs are also advertised as working on the 130XE. The name of the company is Regent, P.O. Box 14628, Long Beach, CA. 90803, (213) 439-9664.

A double-sided disk full of Print Shop<tm> graphics was made available for the disk-of-the-month. GOE was still not here, I suppose we must assume that it will not be here anytime soon. 'Til next time.

P.S. Remember that officer elections are coming up real soon...so if you are interested in a position, please say so. Remember, someone has got to do it, and our president is NOT running again next year (2 years in a row is enough) so someone else will have to. Go for it, folks.

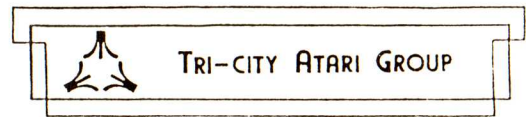

The Tri-City Atari Users Group meets the second Saturday of every month at 2 p.m. at the Rudy Zael Memorial Library on the corner of Shattuck and Center in Saginaw. Upcoming meetings are scheduled as follows: May 13, and June 17, 1989.

LeRoy Valley	President	686-6796
Marty Schmidt	Treasurer/Secretary	792-6029
Al Jennings	ST Disk Librarian	790-1980
Ted Beauchamp	8bit Librarian	686-8872

Club dues are \$20.00 per year. For this fee you get the Atari Interface Magazine, support for both the 8bits and ST's, and full access to the clubs public domain library. We currently have 150 8bit disks and 50 ST disks. 8bit disks cost \$1 each, and ST disks cost \$2 each. Check your mailing label. If you need to renew or you haven't even joined yet, then do it now!

### Letter from the Prez

Summer is just around the corner, and so are the TAG elections. This brings up the instinctive "Not-Me!" syndrome, and (to date) science has not found a cure for this strange User Group based malady. So how can you tell if you are afflicted with this disease? Simply look at the following symptoms:

1) The first symptom occurs when volunteers for monthly activities are asked for. "Not-Me!" syndrome is exhibited by various methods including (but not limited to): Slinking down into your seat to escape detection, Staring vacantly into space, and talking disinterestedly to your neighbor.

2) The second symptom occurs when members are asked to volunteer to fill long term positions. At this point, the individual becomes much more creative and vehement! The first major sign linked to this symptom is the old "Let's get the guy that did that last year to do it again!" trick. When this fails, the infected party then falls back on the even older "Nominate others before they nominate you!" gag.

3) The final (and often fatal) symptom occurs when the infected party (generally nominated by someone before he could nominate them) finally realizes there is no graceful way out. At this point he either begins the road to recovery (by accepting the position), or he stops coming to meetings and dies a slow and painful death due to withdrawal.

In conclusion, if you want to avoid this terrible disease, simply volunteer! I'd like to see someone to make a run for President this year. If that happens, then I'll make a run for ST disk librarian and try to finally get our disk library rolling...Remember, it's up to YOU!

### STill to Come!

The month of May will come rushing in like a C programmer... Say what! That's right, Tom Wheeler will be demoing GST-C by GST Holdings Corporation, the makers of First Word Plus. The club picked up this package at a very reasonable price, and it will be raffled off following the demo! LeRoy Valley will also show some sample C programs after Tom is finished, and will pass out some copies of source code.

Neil Demo will finish up the meeting with a demo of Final Assault by Epyx. This is an action/adventure game that pits you against the elements.

And, maybe, just maybe, there'll be another disk of the month!

### RelicST to Relish!

As promised, Steve Volker demoed Art & Film Director. This package includes both an excellent art program AND an animator! Art Director easily surpasses the capabilities of Neochrome or Degas Elite. You can do things like overlay two pictures, then scrape away part of the top picture to reveal what's underneath, use a section of your picture as a brush, and even cut out irregular sections! The art program alone is superb!

Film Director then allows you to animate your pictures, and even allows you to add a sound track! Art & Film Director is a superb package and well worth every penny at \$79.

The meeting closed with LeRoy Valley demoing some of the goodies on the April disk of the month.

Equipment volunteers for May:

ST Neil Demo Color Monitor

Tom Wheeler 1040 ST

8 Bit Ted Beauchamp Computer and disk drive

Hank Kaufmann Monitor

Remember, if you're bringing equipment, please bring all of the necessary cables (such as power cords, monitor cords, mouses, etc.).



The April meeting of the Washtenaw Atari Users Group was held on April 11 at State Street Computer in Ann Arbor. President Jon Brode gave one of his best renditions to date of "Hear ye! Hear ye!" and then proceeded to announce that Treasurer Dick Selke was home at last from his extended visit to Arizona. (Dick, of course, received a round of applause and was immediately besieged with questions about how much of the club treasury got spent in AZ! Dick smiled, knowingly, and denied all charges...)

Dick gave an in-depth report of the status of the treasury, and recapped his analysis of the financial activity which took place during his absence. The treasury has been fairly stable for the past 10 months.

ST Disk Librarian Russ Crum announced the Disk of the Month special contained printer-driver development utilities, a vertical/horizontal screen dump driver, a print spooler, and several combination RAMdisk/Print Spooler drivers. Eightbit Librarian Mike Millage announced his Disk of the Month contained Daisy Dot II. Both Mike and Russ proceeded to demo these items later in the meeting.

Jon introduced Jay Shuler, a visitor from MacTechnics (a Macintosh-oriented organization from Ann Arbor) who spent

about 30 minutes discussing the possibility of starting a coalition of cross-platform user groups. The idea is to create a link between Mac, NeXT, Atari, Amiga and other computer user groups in the area "in an effort to educate and inform." Jay specifically mentioned a jointly-produced newsletter, group purchases of disks, a mutually funded/operated BBS, and (best of all?) legitimate IRS status as a non-profit organization. Jon invited Jay and/or another representative of the organization to attend the next WAUG officer meeting and further discuss plans and ideas. Questions were fielded from the members and many of them seemed to think the idea to be workable, and were interested in hearing more details in the near future.

Vice President Howard Chu announced he had made arrangements for the club to meet at the Michigan Union (State Street, at South University) starting in May. He has arranged a board room and some A/V equipment for future meetings. There is a parking structure located just behind the union building.

Member Pattie Rayl, representing MACE, discussed progress of the upcoming MACE Atari Show (5/6-7, to be held at the Hilton Inn at Metro Airport). Tickets are now available for advance purchase. Dick Selke put in a plea for members to volunteer time manning the WAUG booth, and also for persons to help work the show.

Jon displayed samples of the Great Lakes Atari Digest (GLAD), a publication looking very much like the original Michigan Atari Magazine (MAM). GLAD is being produced by MAM's originator, John Nagy of CHAOS. John noted that the publishers of GLAD were seeking new subscribers. WAUG members currently receive Atari Interface Magazine as part of their membership privileges. The members seem to be satisfied with this arrangement, so it was decided that any members wishing to subscribe to GLAD should meet with Jon after the meeting to get signed up.

Michael Olin Sec'y

### From the Treasurer

Hi, I'm back! If some of you didn't know, I've been on vacation. Al W. Jones renewed his membership. Hope to see you at MACE Expo, Al!

Speaking of the Expo, we now have our membership cards. Be sure to pick your card up at the Booth before purchasing anything so that you can get a group member discount. We received a lot of compliments on the member cards. A big Thanks to Richard Schrader for the WAUG Logo design, and thanks to Maria of Jerry's Printing on Wayne Rd. in Westland, for being so helpful and efficient. We can use all the HELP we can get at the Booth, volunteer when you can, but stop by and say Hi.

If you are wondering how the Group is doing financially, we had a deficit in Dec.88 of \$70 (purchased blank ST disks and games for door Prizes). We made a \$1.60 in Jan. '89, a loss of \$4.85 for February and a profit of \$4.05 in March. When we took over in June, '88 we had a balance of \$234.48. We now have a Balance of \$241.65.

See you at the Show!

Dick Selke



# Ask NostraTIMus by Tim Sharpe

Have you noticed how boring Atari columnists have become lately? Sheesh, it seems like every time I flip through an Atari magazine I find a plethora of old, regurgitated, time-worn articles...the situation has even degenerated to the point where self-righteous columnists are writing columns complaining about how boring other columnists are!

This month, I offer subject matter that I KNOW will be new and informative —the future! Here are my predictions for the remainder of 1989:

A game called "PAC Man" will be released by Atari. PAC will stand for "Political Action Committee," and the object of the game will be to maneuver either a US Senator or Congressperson around the screen and gobble up bags of cash placed there by Big Business. Atari will announce that the highest scorer in the nation will win a free breakfast with Lloyd Bentsen (A \$10,000 retail value).

An anti-Atari book will appear on bookshelves soon, causing such an out cry in the Atari community that Jack Tramiel will put a \$5.6 million bounty on the head of the author.

The cargo ship "Juan Valdez" will run into an underwater reef and spill 10 million tons of coffee concentrate into the waters near the coast of Brazil. The "fish'll be jumpin'" as the coffee slick oozes its way onto the Brazilian shoreline. Environmentalists will be outraged that the captain of the vessel had been drinking shortly before the incident, and that the crew failed to sober him up because they ran out of coffee. President Bush will dispatch troops to the region to clean up the mess, and the paper towel industry will reap enormous profits.

Elvis Presley will be seen in three different computer stores in Michigan at the same time — and at each store he'll buy a MEGA ST. In May, a high-ranking CACE official will predict that I will make these predictions.

**Software WE'D LIKE TA' SEE!**

There are multiplying disks for copy programs...  
 Silhouetted shapes for background programs...  
 A snoring cloud for inactive, RAM held programs...  
 A mushroom cloud for deleting files...  
 And it works in all resolutions.

**LIKE...**

UNIVERSAL BEAN GENERATOR BY APOLLO

WOW!

This is really amazing software STANLEY!

There are dozens of selectable original icons to use with your favorite software.

You can design your own too!

And uses all 16 colors!

I run in all resolutions.

Yea?..

I use all 16 colors.

Yea?..

I can copy, delete, save, and store inactive programs.

So?...

There's one other Knob.

What's that?...

Oh..Yea... SORRY.

S'alright.

The things I can do with this!

KENNY...

Design my own desktop!

KENNY...

MAKE my computer different than ANYONE ELSE!!!

KENNY!!!

WHAT?

AIM PRESENTS STANLEY & KENNY

©1989 STEVE VOLKER

A. H. H.

May 1989

Events Calendar

SUN	MON	TUE	WED	THU	FRI	SAT
	1	2	<b>GRASS</b> GEnie ST CO 10PM 3	<b>GLASS</b> CIS ST & GEnie 8bit 10PM 4	5	<b>TACE</b> <b>MACE</b> <b>EXPO</b> 6
<b>CACB</b> CIS 8bit CO 9PM <b>MACE</b> <b>EXPO</b> 7	8	<b>WAUG</b> Delphi CO 10PM 9	GEnie ST CO 10PM 10	CIS ST & GEnie 8bit 10PM 11	12	<b>CHAOS</b> ST SIG <b>GKAUG</b> 13
CIS 8bit CO 9PM 14	15	<b>MACE</b> Delphi CO 10PM 16	GEnie ST CO 10PM 17	CIS ST & GEnie 8bit CO 10PM 18	19	<b>CHAOS</b> 8bit SIG <b>TAG</b> 20
CIS 8bit CO 9PM 21	22	Delphi CO 10PM 23	GEnie ST CO 10PM 24	CIS ST & GEnie 8bit CO 10PM 25	26	27
CIS 8bit CO 9PM 28	29	Delphi CO 10PM 30	GEnie ST CO 10PM 31			

AIM Advertisers

Migraph	3
(206) 838-4677	
Word Perfect Corp.	5
(801) 225-5000	
SofTrek	9
(407) 657-4611	
BEST Electronics	11
(408) 243-6950	
Unicom Publications	20
(313) 973-8825	
D&P Computer	23
(216) 926-3842	
Mars Merchandising	23
(801) 225-5000	
Tech-Specialities	24
(713) 691-4527	
ProCo Products	25
(401) 568-8459	

Inside Front Cover:  
1st Stop  
(800) 252-2787

Inside Back Cover:  
Alpha Systems  
(216) 374-7469

Back Cover:  
Avant-Garde Systems  
(904) 221-2904

Atari Corporation Addresses and Phone Numbers

AtariBase BBS	Line 1	(408) 745-5308
	Line 2	(408) 745-5970
	Line 3	(408) 745-2642
	Line 4	(408) 745-4758
	Line 5	(408) 745-5664
Atari Main Switchboard		(408) 745-2000
Atari Customer Relations		(408) 745-2367
		(408) 745-5759
Atari Technical Help		(408) 745-2004
Atari User Group Support	Sig Hartmann	(408) 745-4743
FAX line		(408) 745-4306
Atari Canada		(416) 479-1266
Atari France		011-331-450-66060
Atari Germany		011-49-6142-2090

Corporate Addresses:

Atari Corp. (US)	Atari Canada	Atari France, SA
1196 Borregas Ave.	90 Gough Rd.	9-rue Sentou
Sunnyvale, CA 94088	Markham, Ontario	92150 Surenes
	Canada L3R 5V5	France

Atari Germany GmbH  
Frankfurter Strasse 89-91  
6096 Raunheim  
West Germany

## REVOLUTIONARY NEW PRODUCT



**REQUIRES at  
least 1 meg. of RAM**  
(or a Megadisk or Polydisk Cartridge)

- Imagine Saving almost any game at any point, then being able to return there as many times as you like.
  - Imagine the Ultimate Back-up Utility that actually UNPROTECTS programs as it copies them. Lets protected programs be stored as files, run from a hard disk or even be transmitted over a modem.
  - Imagine saving three or more protected single sided disks on just one double sided disk.
  - Imagine Instantly switching back and forth between two different programs, games, utilities or business applications.
- Now Stop Imagining and get Switch/Back.  
It can do all this and more.**

Switch/Back is a revolutionary new hardware and software package that lets you get more from your ST. MUCH MORE.

Switch/Back's gaming features lets you instantly save most games then continue playing. If you get in trouble you can switch back to where you were as many times as you like.

**BACK-UPS** — Switch/Back can work with your favorite back-up program and allow you to save whole protected disks to files for archival purposes. It can also automatically unprotect a program and save it as standard file. This method works on hundreds of ST programs and it allows you to run the files directly. Its perfect for running protected programs off a hard disk. It creates standard TOS files, that can be stored together on disks or even transferred by modem.

**SWAP** — Switch back lets you load just about any two programs into your ST and switch instantly between them. It works with games, business programs, utilities, compilers, etc. Although only one program is running at a time, the other is available instantly, right where you left off.

The Switch/Back hardware plugs into your printer port for easy use (It has a pass through connection for your printer too.)

Switch/Back requires at least One Meg of memory  
(Or a Polydisk or Megadisk) **ONLY \$69.95**

## ST Protection Techniques



Finally ST Copy protection techniques are revealed. This complete book and disk package details the state of the art in ST Protection methods and much, much more.

The Software included with the book provides many powerful features like the AUTOMATIC PROGRAM PROTECTOR. This easy to use Utility allows you to protect just about any ST program. You can choose a combination of protection methods like encryption, checking custom disk formats, password protection or a limited use option that makes the program self-destruct after running a preset number of times.

The book includes topics such as Phreaking, Logic Bombs, Hardware data keys, the legal aspects of piracy and software protection, Custom disk formats, Pirate Bulletin boards and much more.

In addition it contains reviews of the popular ST back-up programs and detailed explanations of ST disks and drives.

ST Protection Techniques (Book and disk package) **only \$39.95**



High Quality sound digitizer for the ST. This powerful hardware and software package lets you sample real world sounds and play them back on any Atari ST. Add special effects like Echo, Reverse, looping, pitch manipulation, mixing and envelope control. Turns your Atari keyboard into a musical instrument to play songs with your digitized sounds (also works with any MIDI keyboard). Digisound makes it simple to add sound to your own program, too! Unleash the incredible sounds in your ST with DIGISOUND. Supports sampling from 5 to 40Khz. DIGISOUND is the choice of the professionals. DIGISOUND was used to create the voice in Chessmaster 2000, and other commercial programs. **ONLY \$89.95**

## DIGISOUND PROFESSIONAL

All the excellent features of DIGISOUND plus these great extras  
**LOGARITHMIC SAMPLING** — Special hardware extends the sound quality far above the other ST sound digitizers. Logarithmic sampling and feedback (external amplifiers only) greatly extends the dynamic range while reducing distortion and noise.

**Internal Real Time Mixing** — Input from a stereo and a microphone so you can sing over a tape. **\$149.95**

## Beat Box

Is it a Drum Machine? A sequencer? A new concept in digital sound? The answer is - YES!! It's all this - and so much more!! It's a polyphonic song construction set that turns your ST into a drum machine and digital sequencer. Now anyone can be a master composer. No musical knowledge required!

Just point and click to create fascinating drum, voice, or musical patterns in four voices. Combine and arrange patterns to form complete musical compositions. Play the sounds, patterns and songs through your monitor speaker or digitizer hardware.

You don't need a digitizer to enjoy Beat Box. It comes with over 35 ready to use digitized sounds. Or you can use your own sounds recorded with a Digisound ST, Professional, or other digitizer.

**Beat Box \$29.95**

## COLOR COMPUTEREYES™

Incredible COLOR video digitizer. ● The first and only full color digitizer for the ST. ● Uses standard video inputs like video camera, VCR, or video disk. ● Works in all ST resolutions. Low res provides 16 shade black and white or full color pictures. ● Pictures can be used with Degas, Neochrome, Powerprint and others. ● Automatic calibration of contrast, brightness and white balance. ● Plugs into cartridge port for easy set-up. ● Capture your picture or that of your favorite star. **ONLY \$199.95**  
**SPECIAL OFFER** — Buy both Computereyes and Powerprint and SAVE 20.00 from the total.



**BLOW YOURSELF UP**

Imagine your picture on a 6 foot poster. Create a business graph that can cover a wall. Quality output for posters, t-shirts, news letters, and more.

**POWERPRINT**  
Whether it's a photo digitized with ComputerEyes, a masterpiece created with Degas, or the winning screen from your favorite game, POWERPRINT can print it with unequalled clarity and resolution. PowerPrint supports ALL ST resolutions. It prints multiple sizes up to **GIANT WALL SIZED POSTERS**. Print 16 shades for incredible detail. Print the whole screen or **ZOOM** in on just the part you want. POWERPRINT offers unique effects, including rotate, mirror and inverse options. Selective shading option allows you to print multi-color pictures on any printer by printing one color at a time (using color ribbons). Powerprint lets you capture and print almost any ST screen. Works with Star, NEC, Citoh, Gemini, EPSON, XM8048 and compatible printers. **Only \$39.95**

## DIGISPEC

**DIGISPEC** is an exciting new breakthrough in computer video digitizing. **DIGISPEC** works with your Color ComputerEyes to create **spectacular 512 color** video images. Now you can capture and display video pictures in unsurpassed detail and clarity, with 512 different colors on your ST screen.

**DIGISPEC** is easy to use. It works on any ST computer. Simply capture an image with your Color ComputerEyes and color video camera (or VCR, video disk, etc.). Then run **DIGISPEC**, and watch as your picture appears in a full rainbow of 512 true colors.

**DIGISPEC** includes a special shading feature to give you even more detail and color. The shading feature uses a technique called dithering, which creates and displays images in 3,375 or even 24,389 simulated colors.

**DIGISPEC** creates detailed, low resolution video images on any Atari ST, color video camera (or VCR), and Color ComputerEyes. Every Color ComputerEyes needs **DIGISPEC!** **only \$39.95**

**Polydisk** Polydisk is a 512K version of a Megadisk. Polydisk gives you the same fast boot features, the high speed access, and the print spooler. Polydisk has a power supply (like Megadisk) but does not contain a battery back-up.

Note: Those with an 128K of main memory can use Switch/Back with a Polydisk, just like those with one Meg.

Polydisk (512K Solid state drive) **Only \$199.95**  
(Clock option card is also available for Polydisk \$29.95)

24 HOUR HOTLINE — VISA & MasterCard Welcome

**216-374-7469**

Call or write for free catalog.

Customer Service line (216) 467-5665 M-F 9 AM-3 PM EST

Order by phone or send check or money order to:  
**ALPHA SYSTEMS 1012 Skyland, Macedonia, OH 44056**  
Include \$3.00 shp. & hdlg. (US & Canada). Ohio residents add 5 1/2% sales tax. Foreign orders add \$8.00.



# pc-ditto II

By Avant-Garde Systems

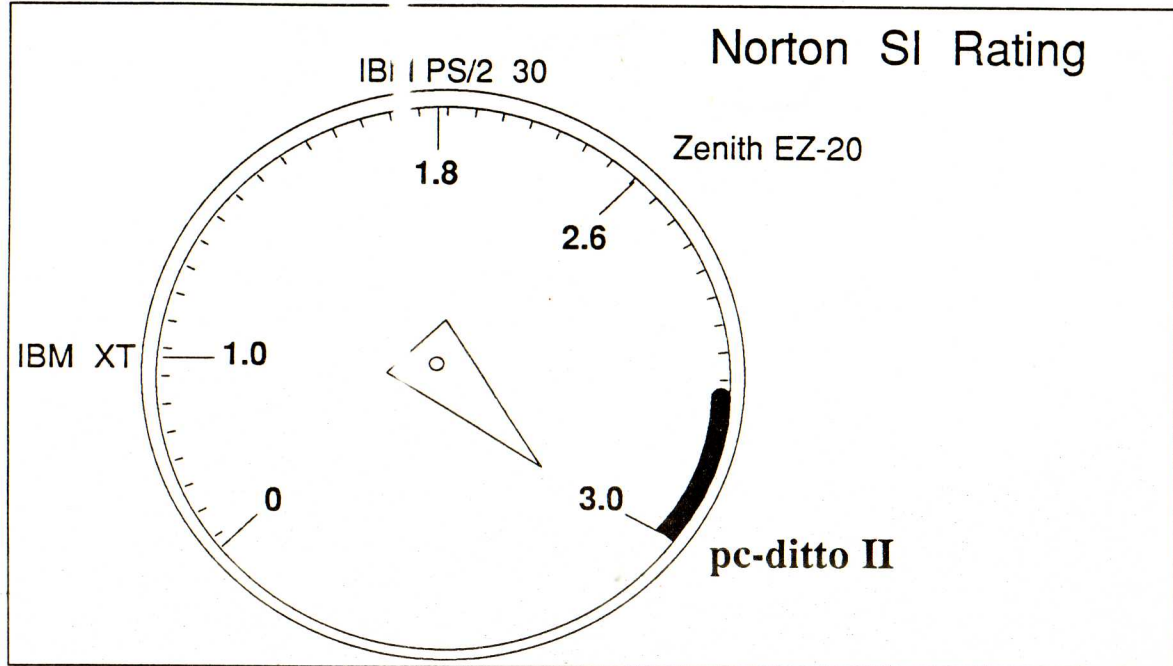

IBM XT COMPATIBLE !

IBM AT PERFORMANCE !

ATARI ST PRICE !

**\$299.95**

Now! Run the most popular IBM software on your Atari ST...

**FAST !**

See pc-ditto II at your local Atari dealer or write for free information.

**ATTENTION pc-ditto owners:** Be sure to return your registration card to receive 50% discount off pc-ditto II

*Yes. Please send me more information !*

Avant-Garde Systems, 381 Pablo Point Drive  
Jacksonville, Florida 32225

Name \_\_\_\_\_

Address \_\_\_\_\_

City \_\_\_\_\_ St \_\_\_\_\_ Zip \_\_\_\_\_

Unicom Publications  
3487 Braeburn Circle  
Ann Arbor, MI 48108  
(313)973-8825

BULK RATE  
U.S. POSTAGE  
PAID  
PERMIT #468  
ANN ARBOR, MI