

ATARI® 400/800™

COMPUTER PROGRAM GRAPH IT™



A Warner Communications Company 

MODEL CX4109
Use with
ATARI® 400™ or ATARI 800™
PERSONAL COMPUTER SYSTEMS

TABLE OF CONTENTS

GENERAL INFORMATION	2
1 INTRODUCTION	2
2 LOADING THE PROGRAM	2
3 PART ONE: BAR CHARTS AND PIE GRAPHS	3
Bar Charts: Example 1	3
Bar Charts Factors: Example 2	5
Bar Charts Statistical Example: Example 3	6
Pie Graphs: Example 1	6
Using Bar Charts and Pie Graphs	8
4 PART TWO: TWO- AND THREE-DIMENSIONAL PLOTS INCLUDING POLAR PLOTS	8
Two-Dimensional Plots	8
Using the Joystick Controller	10
Two-Dimensional Parametric Polar Plots	10
Three-Dimensional X, Y, Z Plots	12
5 SAVING YOUR GRAPHICS	14
6 GRAPH IT™ QUICK REFERENCE GUIDE	14
7 APPENDIX: Two-Dimensional Economics Example	14
8 BIBLIOGRAPHY	15

GENERAL INFORMATION

AGE RANGE: Ages 12 to adult

This program allows the user to:

- Produce bar charts. Title can be up to 20 characters long. Chart can have a maximum of 32 columns. Up to 3 factors per bar are permitted. Column labels are 3 characters.
- Produce pie graphs. Displays 1 to 12 slices. Title and subtitle can have up to 20 characters each. Labels are 3 characters.
- Produce two-dimensional plots. From 1 to 3 functions can be plotted. Choice of 4 plotting speeds. Optional auto-scaling on Y-axis.
- Produce parametric polar plots. Use starting and ending theta value and radian increment. Optional auto-scaling.
- Produce three-dimensional plots. Choice of 2 plotting speeds. Remove hidden lines option and fast non-display while drawing option increases plotting speed.

It develops skills in:

- Visual perception and memory.
- Pattern recognition.
- Understanding mathematical relationships.
- Interpreting data.

It encourages:

- Experimentation/exploration
- Logical and mathematical thinking
- Visual presentation of numerical data

APPLICATIONS AND CATEGORIES OF USE:

- **PROFESSIONAL**—business management, research, forecasting, graphic presentations, statistical analysis.
- **BUSINESS**—sales, management, marketing research, economic analysis.
- **SCIENCE**—chemistry, genetics, physics, electrical engineering.
- **EDUCATION**—algebra, trigonometry, sociology, psychology, harmonic analysis, game theory.
- **PERSONAL**—stock market analysis, budget planning.
- **RECREATION**—makes learning fun.

1 INTRODUCTION

Business and mathematical information is easy to see and understand with the **ATARI GRAPH IT** program. Eye-catching displays of important data relationships and equations are now possible for business people and mathematicians. There are endless applications for graphics in fields that use tools to display information visually and make it simple to understand.

You can create bar charts, pie graphs, two- and three-dimensional plots and polar plots on your television screen with **GRAPH IT**. You can use a Joystick Controller to find X, Y and slope values of two- and three-dimensional plots.

This manual is divided into two parts. **PART ONE** describes the **BAR CHARTS** and **PIE GRAPHS** programs. **PART TWO** illustrates the plotting of mathematical functions on two- and three-dimensional coordinate systems, and polar plots. There are five related programs in the **GRAPH IT** package.

PART ONE:

- **BAR CHARTS**
- **PIE GRAPHS**

PART TWO:

- **TWO-DIMENSIONAL X, Y PLOTS**
- **TWO-DIMENSIONAL POLAR PLOTS**
- **THREE-DIMENSIONAL X, Y, Z PLOTS**

2 LOADING THE PROGRAM

The **ATARI® GRAPH IT™** programs will run on an **ATARI 400™** or an **ATARI 800™ Personal Computer System** with a minimum of 16K Random Access Memory (RAM). The five graphics programs are on two cassettes:

- Side 1 of Cassette A contains two programs:

BAR CHARTS
PIE GRAPHS

You can run either of these two programs in 16K RAM, but in order to run the **BAR CHARTS** program after running the **PIE GRAPHS** program it is necessary to reload the program from the cassette first. This is because the **PIE GRAPHS** program will erase and use the memory space occupied by the **BAR CHARTS** program. Systems with more than 16K RAM will be able to run the **BAR CHARTS** and **PIE GRAPHS** programs without reloading.

- Side 2 of Cassette A contains TWO-DIMENSIONAL X, Y PLOTS.
- Side 1 of Cassette B contains POLAR PLOTS.
- Side 2 of Cassette B contains THREE-DIMENSIONAL X, Y, Z PLOTS.

Use the following procedure to load your GRAPH IT program cassette:

1. Connect your ATARI 800 or upgraded ATARI 400 Personal Computer System to your television as instructed in your Operator's Manual.
2. Connect the data cord attached to your ATARI 410™ Program Recorder to the PERIPHERAL connector on the side of your ATARI Personal Computer System.

NOTE: If you have "daisy-chained" peripherals to your computer console, and do not wish to disconnect them, connect your ATARI 410 Program Recorder to the I/O CONNECTOR of the last unit in the chain.

3. Connect the power cord attached to your ATARI 410 Program Recorder to a wall outlet (110/115VAC).
4. Make sure that at least 16K RAM is installed in your ATARI Personal Computer System. See your ATARI 800 Operator's Manual for Memory Module loading instructions, if necessary.
5. Insert the ATARI BASIC (Computing Language) Cartridge into the computer console cartridge slot. (Insert in the LEFT CARTRIDGE slot on the ATARI 800 Personal Computer System.)
6. Turn on your television set.
7. Turn on your ATARI Personal Computer System by pressing the POWER switch on the right side of the console to ON.
8. If all equipment is properly connected and powered up, your television screen should be displaying the READY prompt, with the white square "cursor" immediately below.

See the **NOTE** at the end of these installation and loading instructions if you have loading problems.

9. Press STOP/EJECT on your ATARI 410 Program Recorder to open the cassette door.
10. Hold Side 1 of GRAPH IT Program Cassette A so that the cassette label is up and the tape leader is facing you.
11. Slide the cassette into the cassette holder and close the door.
12. If necessary, press REWIND and rewind the tape to the beginning of the program. When the tape is rewound, press STOP/EJECT.
13. Type CLOAD on the console keyboard and press the **RETURN** key.

14. When the beep sounds, press PLAY on the Program Recorder and hit **RETURN** again.
15. Wait for the operating system to load the program.
16. When the READY prompt appears on the screen again, type RUN and press **RETURN** on the console keyboard.
17. When the ATARI logo is displayed on the screen you will hear another beep, and the computer will automatically load the ATARI GRAPH IT BAR CHARTS and PIE GRAPHS program. When loading is complete, a MENU will display, and the program is ready to use.

The loading procedure steps should be repeated each time you wish to load and run a different GRAPH IT program. The programs are identified by name on the cassette tapes themselves.

- NOTE:**
1. If an ATARI Disk Drive is connected to the computer, the Disk Operating System (DOS) and system software use some of the available RAM. The amount of RAM used varies with the version of DOS that you are using. This overhead needs to be taken into account when calculating the amount of RAM required to run a program.
 2. If you have problems loading the program, and if you have other peripherals in addition to the ATARI 410 Program Recorder attached to the computer console, try disconnecting the other peripherals and connecting the Program Recorder directly into the console to isolate the problem. If loading problems persist, consult the ATARI 410 Program Recorder Operator's Manual.

3 PART ONE: BAR CHARTS AND PIE GRAPHS

BAR CHARTS: EXAMPLE 1

Imagine that you wish to tell stockholders that business is good at your company. You have the following sales figures:

GLOBE WINE SALES

YEAR	SALES (Millions of Dollars)
1	1
2	2.1
3	2.3
4	4
5	10
6	9
7	16
8	20
9	28
10	30

The underlying trend can be visually and clearly illustrated with a bar chart. When you load the BAR CHARTS and PIE GRAPHS programs from Side 1 of Cassette A you see a MENU of choices.

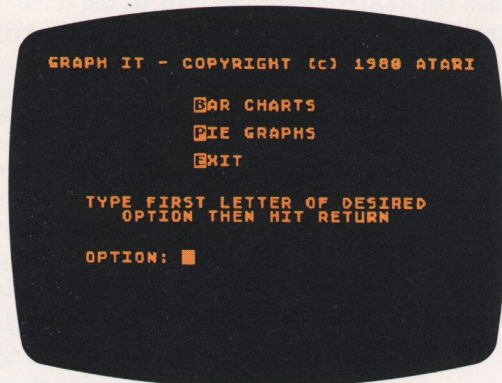

Press **B** and **RETURN** and you will see:

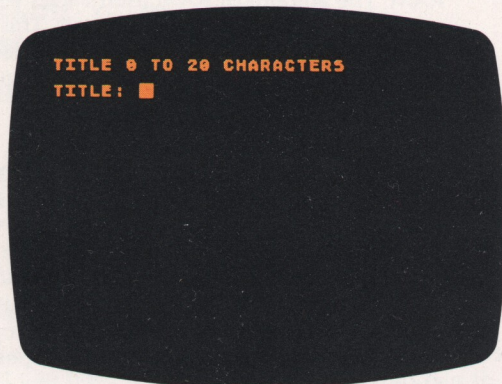

You type in **SALES INCREASE** and press **RETURN**. **SALES INCREASE** will be the title of the bar chart. If you make a mistake in typing this title, you can use the **DELETE BACK S** key to make corrections. The **DELETE BACK S** key can be used to make changes and corrections any time a keyboard entry is typed. The **INSERT** and cursor control keys (the arrowhead keycaps) can also be used for changes and corrections. See your Personal Computer Operator's Manual for instructions on using the screen editing functions.

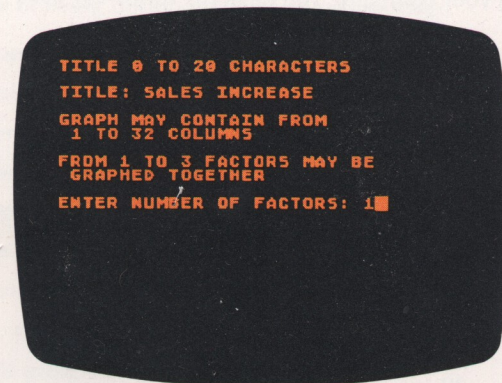

Enter **1** and press **RETURN**.

The **FACTORS** entry tells the computer how many color breaks are to be made in each bar. A bar can be divided into a maximum of three colors (this shows up as three distinct shades on a black-and-white television).

Now you enter the column labels. Up to 3 characters are allowed. Use one character for each label, the years 1 through 10. Type:

- 1 **RETURN**
- 2 **RETURN**
- 3 **RETURN**
- 4 **RETURN**
- 5 **RETURN**
- 6 **RETURN**
- 7 **RETURN**
- 8 **RETURN**
- 9 **RETURN**
- 10 **RETURN**

The screen holds 8 labels and scrolls up one place so that you will see **COLUMN 10 LABEL:** after you have typed **9 RETURN**. Then type **10 RETURN** for the last label. You don't have the sales figures for the 11th year, so press **START**.

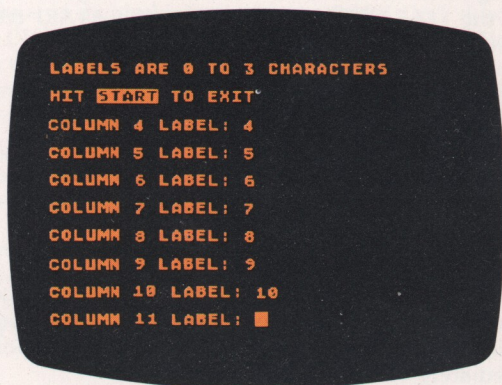

You have pressed **START** for **COLUMN 11 LABEL:** so you will now be asked to enter the percentages for the individual bars. You have only **FACTOR 1**, the sales figures themselves. For **FACTOR 1** type:

- 1 **RETURN**
- 2.1 **RETURN**
- 2.3 **RETURN**
- 4 **RETURN**
- 10 **RETURN**
- 9 **RETURN**
- 16 **RETURN**
- 20 **RETURN**
- 28 **RETURN**
- 30 **RETURN**

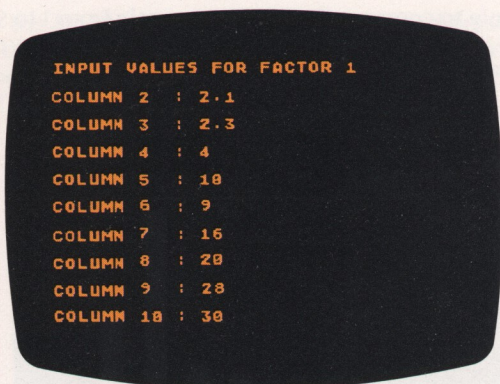

After entering all the sales figures and pressing **RETURN** for the last entry, **COLUMN 10**, the graph will automatically start taking shape. The computer scales your input data so it will fit on the screen.

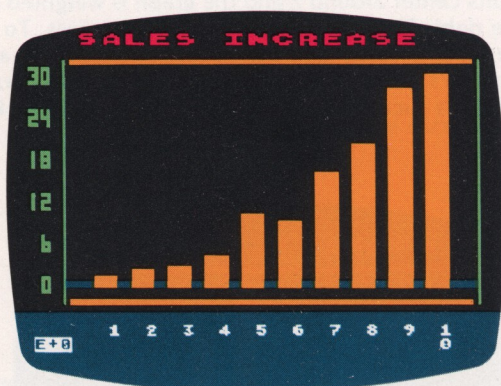

There, that should give the message to stockholders. You might have to do some explaining about the 6th year, but the underlying trend is clear. The **E+0** notation in the bottom left corner of the screen is scientific notation, and means the decimal is placed exactly as you see it on your screen—**30** million for the 10th year. If the notation were **E+1**, the decimal would be one place to the right of the amounts on the screen.

An original entry of **300** becomes **30.0 E+1** using scientific notation. Scientific notation uses an exponent (abbreviated by the letter **E**) to indicate the location of the decimal point. This notation is a shorthand way of expressing numbers. A positive (+) sign after the **E** tells you to move the decimal to the right and a negative (-) sign after the **E** tells you to move the decimal to the left. Thus, **5E+3** expresses the number **5000**, while **5E-3** expresses the number **.005**.

To return to the **MENU** press any key and the question **EXIT (Y/N)** will appear at the lower left of the bar chart. Typing **Y** and pressing **RETURN** gets you back to the program **MENU**.

BAR CHARTS FACTORS: EXAMPLE 2

Mary Jones would like to have a chart showing the amount of money she has spent on food, transportation and clothing during the last five months. The three factors will show up as different colors (or shades on a black-and-white television).

With the **BAR CHART** and **PIE GRAPH** programs loaded, select **B** from the **MENU** and press **RETURN**. For a title type **FIVE MONTH BUDGET** and hit **RETURN**. The computer asks for the number of factors. Type **3** and **RETURN**. **COLUMN LABELS** are:

JAN **RETURN**
 FEB **RETURN**
 MAR **RETURN**
 APR **RETURN**
 MAY **RETURN**

Press **START**.
 Factor 1 is food. Type:

100 **RETURN**
 120 **RETURN**
 123 **RETURN**
 130 **RETURN**
 133 **RETURN**

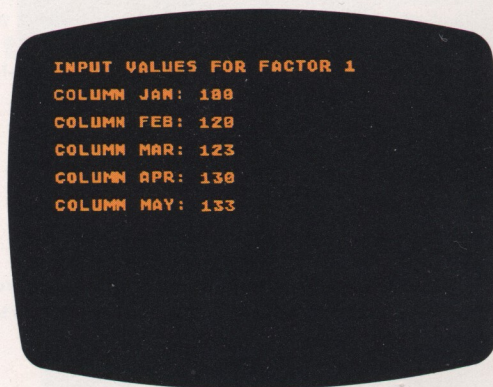

Pressing **RETURN** after **COLUMN MAY**: causes the computer to go on to the second factor, transportation. Type the amounts:

60 **RETURN**
 65 **RETURN**
 275 **RETURN**
 90 **RETURN**
 65 **RETURN**

When entering the factors, if you enter a character that is not a number, the computer will respond with **INVALID INPUT** and will give you another chance to enter the data correctly. If, however, you enter the wrong number and realize it after you have pressed **RETURN**, there is no way to correct it. You must restart the program by pressing **BREAK** and typing **RUN RETURN**.

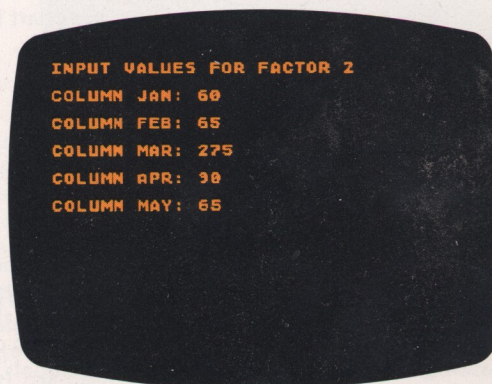

For the third factor, clothing, type:

20 RETURN
 90 RETURN
 0 RETURN
 40 RETURN
 35 RETURN

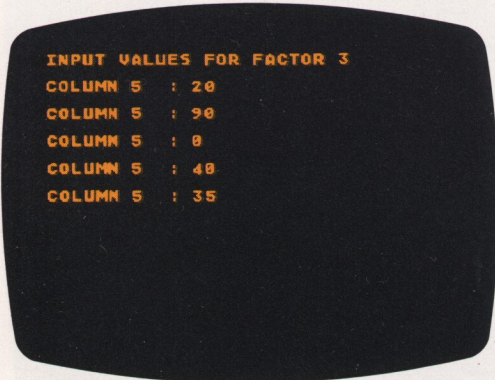

Press RETURN and things will start taking shape. The program calculates the size of each factor and scales the bars to fit on the screen.

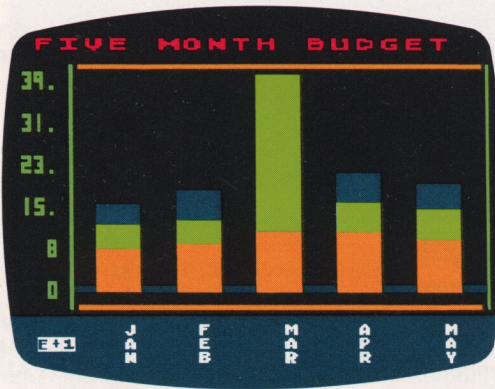

To get back to the MENU press any key on your keyboard and you will see the question EXIT (Y/N). Type Y RETURN and the MENU will appear on the screen. The exponent E+1 at the bottom left means the decimal place is really one place to the right. Thus, the largest amount on the bar chart is 398.

BAR CHARTS STATISTICAL EXAMPLE: EXAMPLE 3

Marketing Research Study of Wine Labels

The Globe Wine Company wishes to market a new wine. The company is wondering how people will react to its new label—a picture of grapes, with a map of the world in the upper right corner. Globe does some marketing research on the label by asking 100 people to rate a selection of labels. They

ask people to compare the labels on a scale from 1 to 9 (with 9 being “most liked”). The results out of a sample of 100 people are:

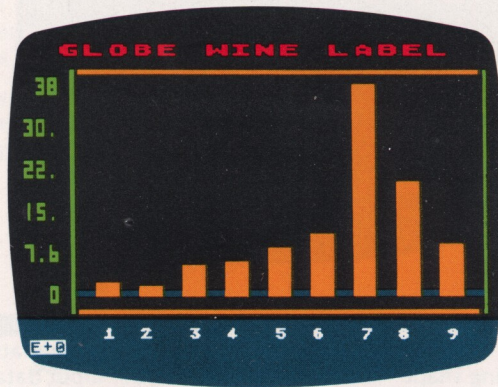

The results center around 7 and the graph is weighted heavily to the right. The label appears to be a success. To make sure the label is really OK, the people’s reaction to a competing brand’s label is necessary. The competing brand is known to be a success. A graph of the competition looks like this:



It seems that Globe’s new wine label will be a star. The results of the Brand X ratings center around 5. However, management must also graph reactions to the taste of the wine, and other considerations. There are many statistical tests that can be performed on the data used in the bar charts of Globe and Brand X. Are the differences between ratings on a 1 to 9 scale for taste, color, and label really significant or could they be due to chance alone? Statistical analysis will aid in judging the situation, but the trend is apparent from the bar charts.

PIE GRAPHS: EXAMPLE 1

The relationship of a single item to the total is made especially clear with a pie graph. The pie graph is often used to show how sums of money are spent. An example from the Federal Reserve System shows how a pie graph can make Federal Reserve Member Bank earnings clear at a glance.

FEDERAL RESERVE BANK EARNINGS (1941-1953)	
DIVIDENDS	8%
OPERATING EXPENSES	36%
TO U.S. TREASURY	39%
SURPLUS	17%

From the MENU, type **P** for PIE GRAPHS and press **RETURN**. Your display asks for a title. Type **FEDERAL RESERVE** **RETURN** for the main title. Later in the program you can choose a subtitle for the pie graph.

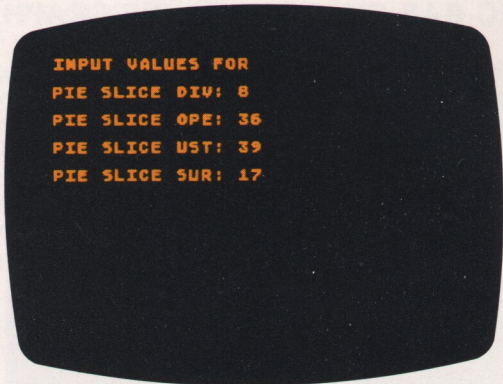
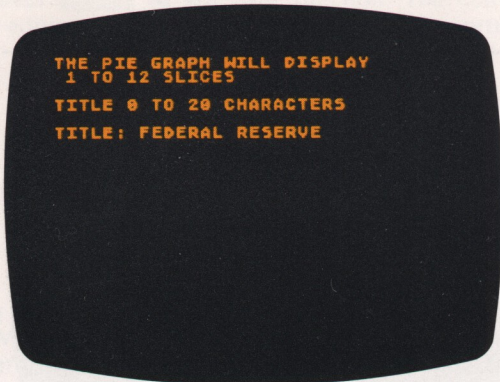

The next display appears automatically after each pie slice is given an amount and the last input is ended with a **RETURN**. Type the Subtitle **BANK EARNINGS** and press **RETURN**. Hitting **RETURN** without giving a subtitle will yield **PIE GRAPH** as a title under the graph.

Next you want to enter labels for the pie slices. You type:

- DIV **RETURN**
- OPE **RETURN**
- UST **RETURN**
- SUR **RETURN**

These abbreviations stand for **DIVIDENDS, OPERATING EXPENSES, TO U.S. TREASURY**, and **SURPLUS**: Labels are limited to 3 characters. When the choice **PIE SLICE 5 LABEL:** appears, press **START** to go on.

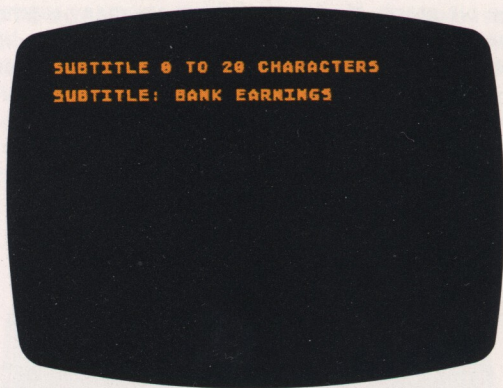

The program will start to draw the pie graph on your screen as soon as you press **RETURN**.

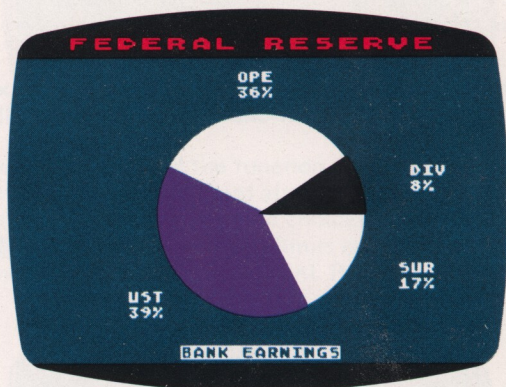
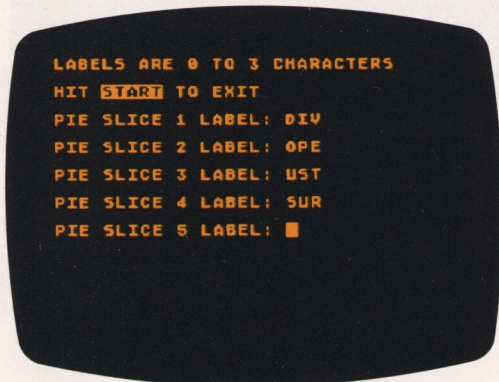

Now you fill in the amounts. In this example percentages are used, but the program is capable of calculating percentages from raw data. Type:

- 8 **RETURN**
- 36 **RETURN**
- 39 **RETURN**
- 17 **RETURN**

Should one or more pie wedges occupy less than 1/14th of the pie, they will be grouped together with the label **ETC.** Press any key and the question **EXIT (Y/N):** will replace the subtitle. To get back to the MENU press **Y** **RETURN**. To keep the screen display and subtitle as it was, press **N** **RETURN**.

NOTE: If you want to run the BAR CHARTS program after running the PIE GRAPHS program, you will need to reload the program (Side 1 of Cassette A) first, unless your computer has more than 16K RAM.

USING BAR CHARTS AND PIE GRAPHS

Numerical relationships form the basis of business decisions. Data is being generated in large quantities by companies that need to analyze sales figures, marketing research figures, and computer generated figures of all kinds. The bar chart and pie graph offer a method to quickly grasp key trends. Graphing has a wide range of applications. Anything that can be expressed as a quantity can be pictured on either a bar chart or pie graph. In most cases, data can be put on either one. The choice is yours.

Usually a bar chart is picked to display statistical data. In the wine label example it is easy to see the central tendency, or mean, of the data.

The pie chart is good for displaying economic data. Americans are especially familiar with the yearly fiscal budget pie graph. At the end of the year the government releases the amount of money spent on administration, armed forces, welfare, etc.—figures which are made manageable and comprehensible thanks to pie graphs. In a similar fashion, private companies use pie graphs in annual reports to show how the stockholders' money is spent. The eye can quickly see the relationships as part of the whole with the pie graph. However, if there are many segments, or if the segments are of equal size, then the choice between bar chart and pie graph should probably go to the bar chart.

4 PART TWO: TWO- AND THREE-DIMENSIONAL PLOTS INCLUDING POLAR PLOTS

If you can define something as a function, you can watch it plot with the GRAPH IT TWO- and THREE-DIMENSIONAL PLOT programs. The French philosopher and mathematician, Descartes, is credited as being the father of the coordinate system. There are four sections, or quadrants, in this system. The coordinate system bar charts you used in PART ONE are taken one step further by adding a negative direction.

With the bar chart, the points X, Y are plotted in a positive dimension only. Thus, a bar chart might have the following points.

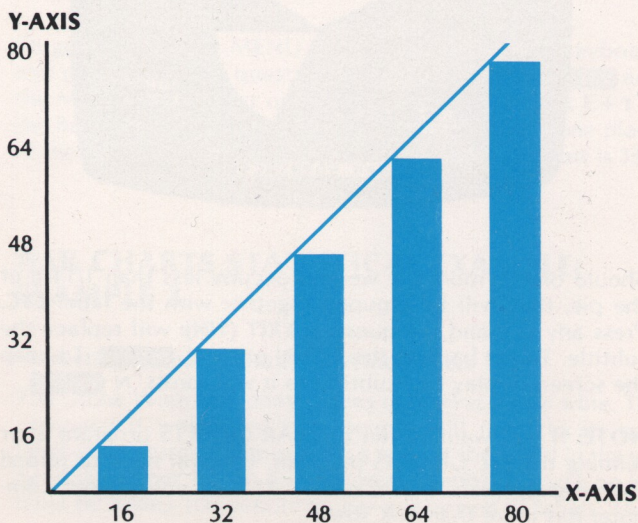

In this chart the negative direction is not seen. All values are positive. Adding a negative direction you uncover...

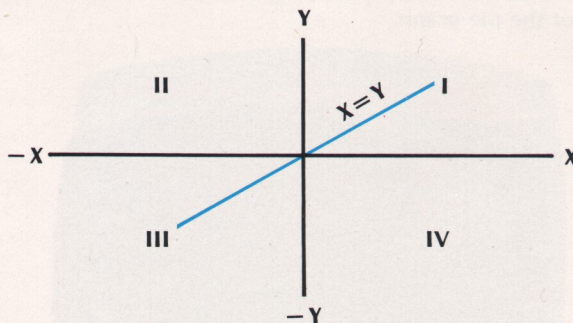

Now there are four quadrants.

The equation of the line, that you got by just taking points $X=16, Y=16; X=32, Y=32; X=48, Y=48$, is $X=Y$. With a bar chart you do not have a negative direction. With the coordinate system there is a negative direction with $X=-16, Y=-16$ and $X=-32, Y=-32$, etc. The equation of this line is still $X=Y$ but unlike bar charting there is now a negative direction.

TWO-DIMENSIONAL PLOTS

Side 2 of Cassette A contains the TWO-DIMENSIONAL X, Y PLOTS program. Load the program as described in Loading the Program, inserting the cassette in the Program Recorder with Side 2 up and first rewinding the tape to the beginning. The first display after the ATARI logo is:

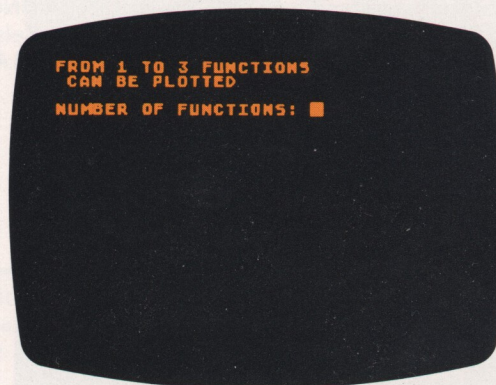

Press 2 and RETURN.

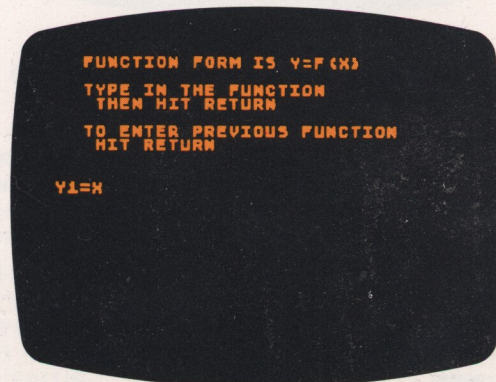

Enter X and **RETURN**.

The Enter Previous Function **RETURN** feature is very helpful if you wish to make a minor change or keep the Y1 function the same after you see what a plot looks like. If a very long function is entered and you discover a mistake after the plot is drawn, you can press **R** **RETURN** to get back to Y1= and then press **RETURN** to see your function. The computer's screen editing capabilities can be used to make corrections.

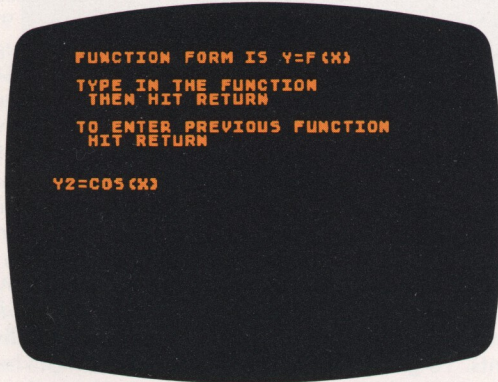

Enter **cos(x)** and press **RETURN**.

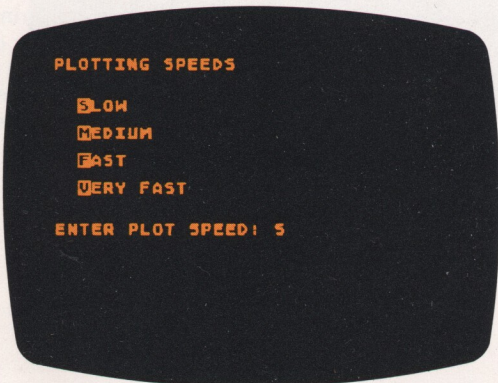

Press **S** **RETURN**.

The faster the plotting speed, the quicker the function will be drawn on the screen. But there is a price to be paid for speed. The **VERY FAST** speed does not plot as many points as the **SLOW** speed. At fast speeds there is less resolution. Also, the Joystick Controller will not give you the highest slope accuracy for functions plotted at fast speeds (refer to Using the Joystick Controller). **VERY FAST** is perfect for a quick look or for previewing a function.

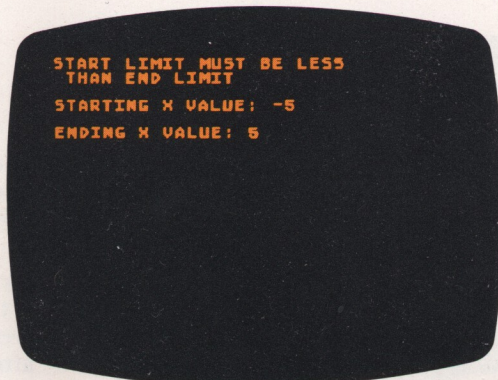

Type **-5** and press **RETURN**.
Type **5** and press **RETURN**.

This gives a compact view of the cosine function along the X-axis. The greater the value you choose for the negative and positive X-axis, the more cosine waves appear on the screen.

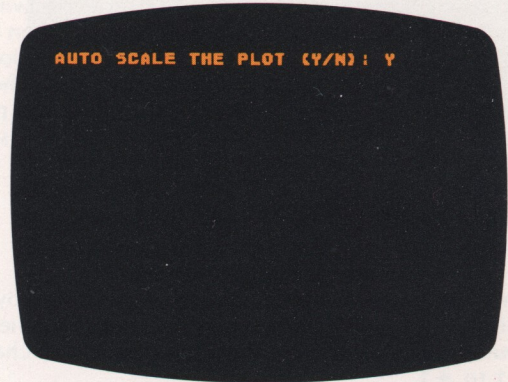

Press **Y** and **RETURN**. The word **SCALING** will appear.

The **AUTO SCALE** function scales the plot to make sure that all of the peaks of your function fit on the screen. This might cause the scale of the Y-axis to differ from the scale of the X-axis. When plotting two or more functions this may cause a visual distortion of one of the functions. The Joystick Controller is helpful in finding the Y-axis value the **AUTO SCALE** chooses. Thus, after you pick the X-axis values, the **AUTO SCALE** picks the Y-coordinate values so that all functions will fit on the screen.

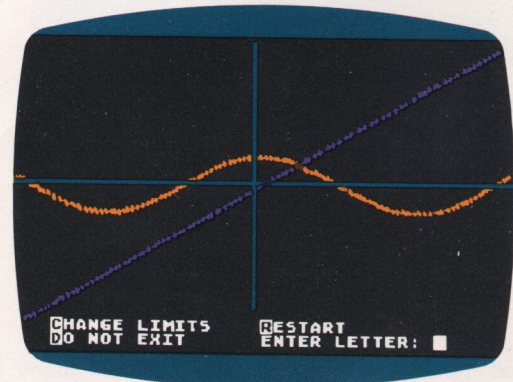

To change the limits of the function or reenter the program press any key on the keyboard after the plot is completed. At the bottom of the screen a list of choices will appear. Press **C** and **RETURN** to change function limits or press **R** and **RETURN** to reenter the **TWO-DIMENSIONAL PLOTTING** program.

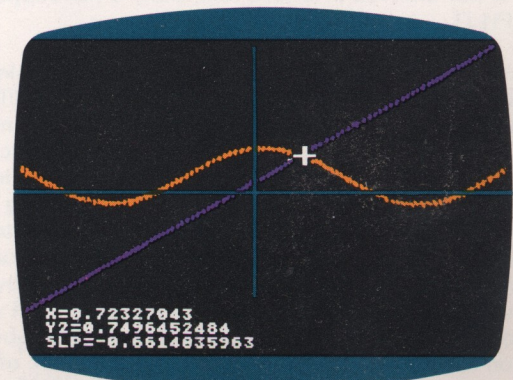

USING THE JOYSTICK CONTROLLER

Plug the Joystick Controller into CONTROLLER JACK number 1, the far left position on the front of the computer console. Hold the controller with the red trigger button in the upper left corner, as shown below. By pressing the Joystick forward and pushing the button, you will get readings for X, Y and slope. These readings can be seen in the lower left of your screen. For the straight line function the slope is 1. The program figures the slope by taking the two points closest to the cursor location. Let's call these points X1, Y1 and X2, Y2. Point X2, Y2 has larger X, Y values than point X1, Y1.

The slope formula is:
$$\frac{Y2 - Y1}{X2 - X1}$$

To get readings along the cosine function, press the Joystick in the direction you wish to see a readout (also press the Controller button). You will find that the slope gradually changes from -1 to +1.

Joystick Controller Cursor Readout

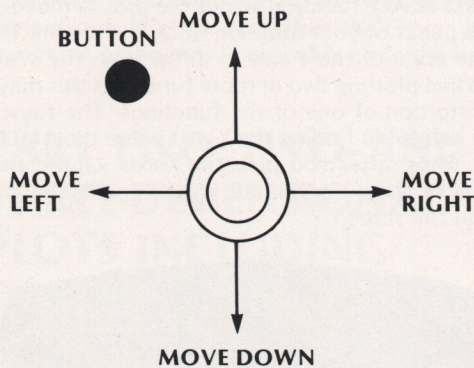

- Push the Joystick forward to have cursor appear on the screen.
- Move Joystick in direction you wish cursor to go.
- Press button for slope, X, Y, and Z coordinates.

Any good mathematics textbook will contain many functions for plotting. The *Standard Mathematical Tables* handbook published by The Chemical Rubber Co. (see Bibliography) is an excellent source of equations.

NOTE: Only functions supported by the **BASIC** language can be used with the TWO- and THREE-DIMENSIONAL PLOTTING program. For example, the square root of a negative number is not allowed in **BASIC** and, thus, is not supported by GRAPH IT.

There are many "real world" uses for two-dimensional plotting. Appendix A uses the TWO-DIMENSIONAL PLOTTING program in an economics example—the supply and demand curve. Other two-dimensional plotting applications include physics, chemistry, genetics, psychology, electrical engineering. The subject of curve fitting is both fascinating and useful in modern life. Generally speaking it is possible to approximate almost any line or curve with a function. A periodic pattern, for example, can be approximated by adding a sufficient number of sine and cosine terms with varying periods and amplitudes. There are many excellent books written on this subject. The Bibliography at the back of this manual provides a starting point.

TWO-DIMENSIONAL PARAMETRIC POLAR PLOTS

The GRAPH IT POLAR PLOTS program can be used to create and study many interesting geometric shapes. In the TWO-DIMENSIONAL X, Y PLOTS program, you plotted points X1, Y1 by solving an equation to find the value of Y1. A starting negative limit of -5 in the equation Y1=X, gave you the values -5, -5. The program plotted this point and then plotted another Y value by solving the Y1=X equation. The resulting series of individual points -5 and -5, -4.99, and -4.99, -4.98 and -4.98 made a straight line through the origin (point where the X-axis crosses the Y-axis). Solving equations that begin Y1= will never give you an equation that doubles back to form a circle. You will always get straight and wavy lines when you permit a definition of Y only in terms of X. In parametric polar plotting two equations are used, X= and Y=. The word "parametric" means that you are describing your polar function using two variables (parameters), X and Y. True polar equations define an angle theta (T) and a distance r away from an origin. The GRAPH IT program uses the equations for X= and Y= to convert the polar system to the rectangular system of plotting individual X, Y points. To get the idea of how this is accomplished it is necessary to first look at how you might go about drawing a circle.

If you could somehow plot functions by defining a central origin point and a distance from that point (radius), then you would be able to plot a circle. This is like tying a string to a pencil and tacking the other end of the string to the origin. The string represents a constant value and the rotation of the string in the circle represents increasing the angle from 0 to 360 degrees. This can be expressed in trigonometry as:

$$\begin{aligned} \cos(T) &= \frac{X}{r} \\ X &= r \cos(T) \\ \sin(T) &= \frac{Y}{r} \\ Y &= r \sin(T) \end{aligned}$$

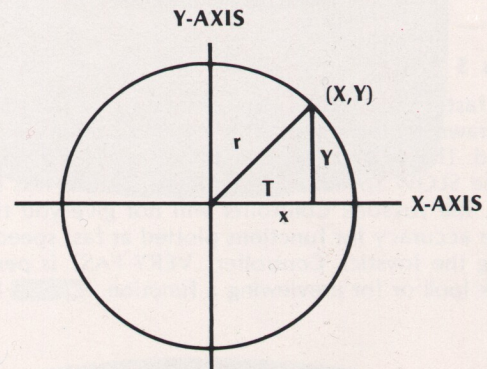

When $r=1$ (or any constant) you have a circle.

Remember that the word "parametric" means you are describing the polar function as two variables (parameters), X and Y. With the equations $X=r \cos(T)$ and $Y=r \sin(T)$ you can plot a circle with $r=1$ or any other constant.

The GRAPH IT POLAR PLOTS program is on Side 1 of Cassette B. Load the program as described on page 3. This program allows you to tell the computer to plot a circle according to your wishes. The first screen instruction after the ATARI logo asks us to define X= in the form F(T).

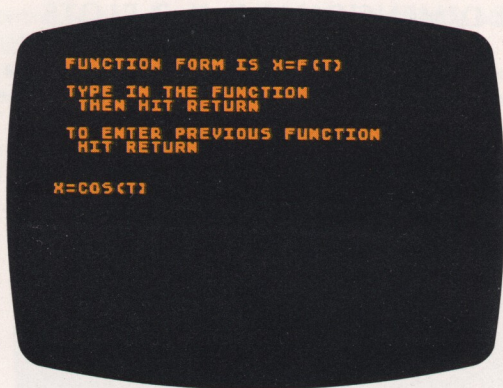

Type **COS (T)** . Remember you are talking about an angle (T) so it is necessary to put T for Theta in parentheses. Next you are asked about Y:

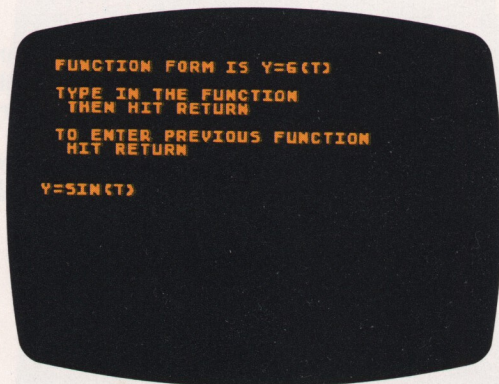

Type **SIN (T)** and press to continue. Enter a starting value of **0** . Since you want to describe a circle from 0 to 360 degrees, enter an ending value of **6.3** . To convert from degrees to radians is not difficult. By definition 2 times 3.14159 (pi) times radians equals 360 degrees. By multiplying $2 * 3.14159$ and rounding off to the second decimal place you get 6.3. If you wish to go only half way around the circle (180 degrees) you can use 3.15. The T increment **.1** gives you a very good resolution (the number of points plotted).

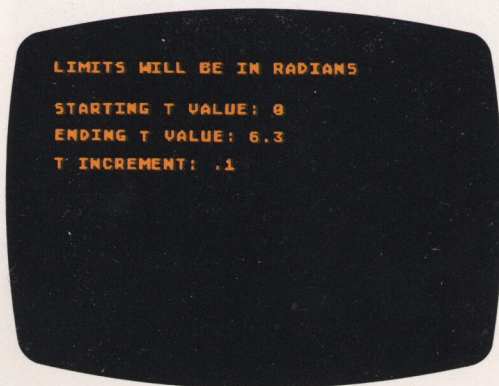

Next you are asked:

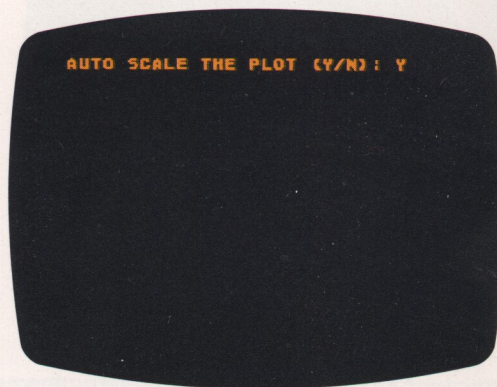

Press **Y** since you want the whole circle to fit in the display. Using **AUTO SCALE** ensures that you will be able to see the plot. The word **SCALING** will appear to let you know that the program is computing the upper and lower limits for including all of your circle on the television screen.

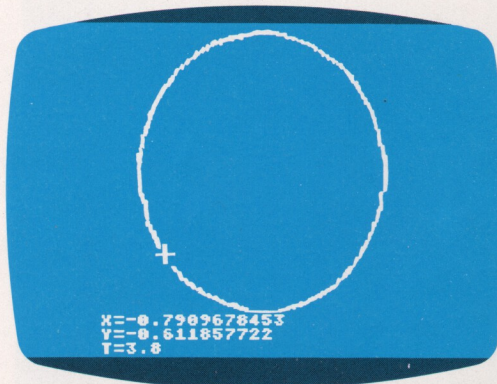

Using the Joystick Controller you can get readings of X, Y and T for every point plotted on the circle.

To reenter the program or change limits press any key on the keyboard. Type **R** and press to return to the program or type **C** and press to change the radian limits.

Now you are ready for something more sophisticated and fun than a circle: a polar flower. To grow a polar flower:

1. Define **X = COS (1.5*T) * COS (T)**
2. Define **Y = COS (1.5*T) * SIN (T)**
3. Starting T value: **0**
4. Ending T value: **13** (It takes 720 degrees to make this flower)
5. T increment: **.1**
6. **AUTO SCALE** the plot (Y/N): **Y**

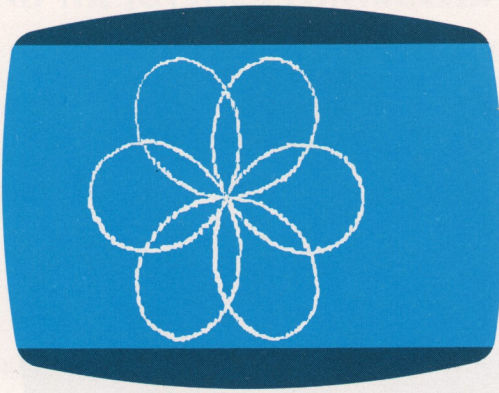

You can think of a polar function in parametric form as expressing r as an equation and placing it in the two (X, Y) forms:

$$X = r * \text{COS}(T)$$

$$Y = r * \text{SIN}(T)$$

For example, given $r = 1 - \text{SIN}(T)$

$$X = r * \text{COS}(T) = (1 - \text{SIN}(T)) * \text{COS}(T)$$

$$Y = r * \text{SIN}(T) = (1 - \text{SIN}(T)) * \text{SIN}(T)$$

Use a starting T of 0 and an ending T of 6.3 with a $.1$ increment. This will draw a heart.

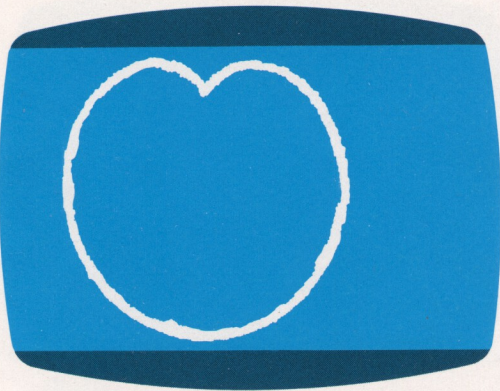

Want to draw a spiral? The higher the ENDING T VALUE the more turns you get, with

$$X = (T) * \text{COS}(T)$$

$$Y = (T) * \text{SIN}(T)$$



Experimenting with polar functions is easy when the computer does the plotting.

THREE-DIMENSIONAL X, Y, Z PLOTS

It is possible to simulate a third dimension on a two-dimensional television screen. The effect looks something like a blanket thrown over a three-dimensional object. Think of a loaf of bread. The Z dimension is the height. The Y direction is the length of the bread and the X direction is the width.

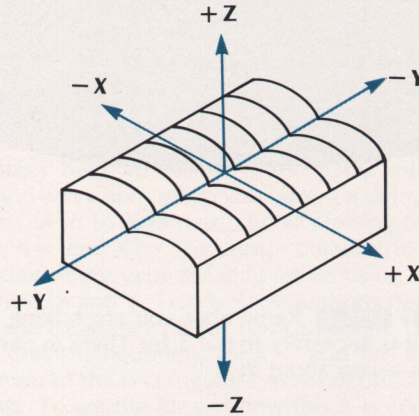

A "saddle" function is an example.

Side 2 of Cassette B contains the THREE-DIMENSIONAL X, Y, Z PLOTS program. Load the program as described in Loading the Program, inserting the cassette in the Program Recorder with Side 2 up and first rewinding the tape to the beginning. The ATARI logo will appear briefly and will be followed by the screen below. Type $X*X - Y*Y$ and `RETURN` as shown.

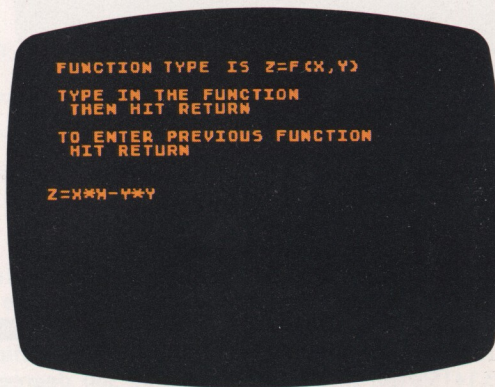

After you press `RETURN`, type `S` `RETURN` when you are asked for plot speed. This will give you the highest detail for your "saddle."

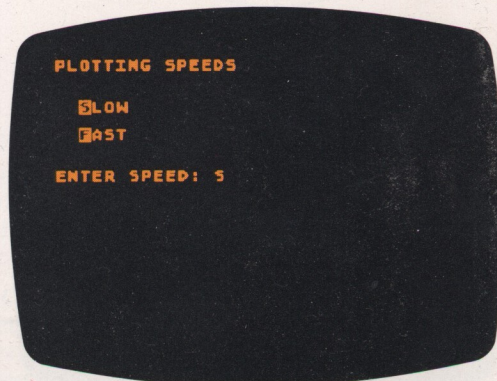

For starting and ending values enter `-10` `RETURN`, `10` `RETURN`,
`-10` `RETURN`, `10` `RETURN`.

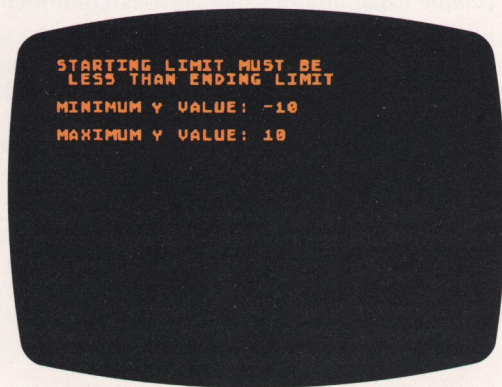
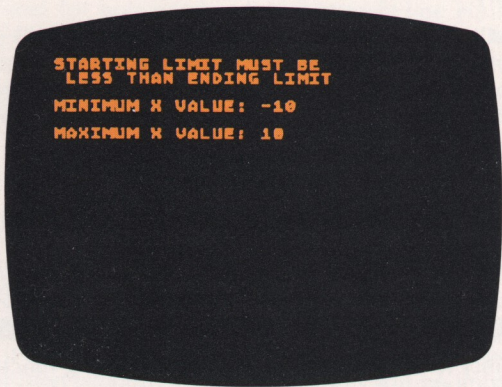

Type `N` `RETURN` in response to the question **AUTO SCALE (Y/N)**. In this case you don't want **AUTO SCALING** because it would flatten the saddle. The Z limits are `-10` `RETURN`, `10` `RETURN`.

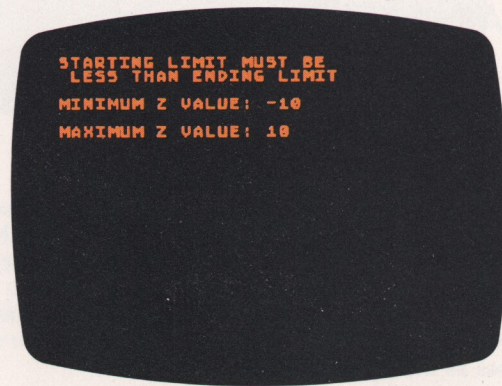

In this example the hidden lines are not important. By typing `N` `RETURN` in response to the question **REMOVE HIDDEN LINES (Y/N)**: the plotting speed will be improved. If you wish to see the saddle as it is being drawn type `N` `RETURN` to the question **FASTER NON DISPLAY PLOT (Y/N)**. It is interesting to watch the drawing process, even though the plotting time is longer.

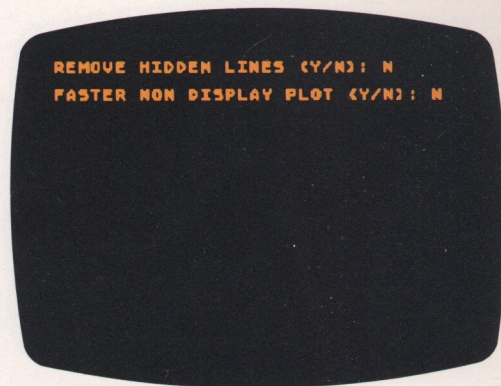

The program displays the approximate plotting time.

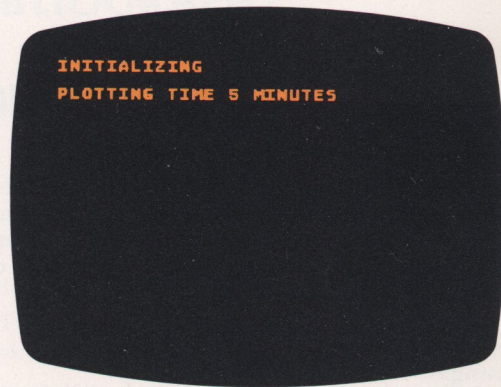

On the screen you see:

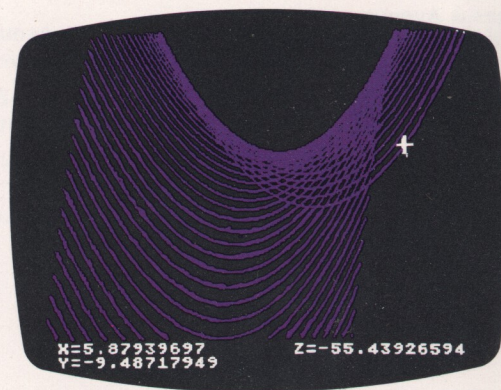

To reenter the program or change limits, press any key on the keyboard. Type `R` and press `RETURN` to reenter the program or press `C` and press `RETURN` to change the limits.

You can use the **Joystick Controller** to trace along your plots.

Analytic geometry is a rich source of 3D equations. A sine wave takes on a whole new character in three dimensions. Try plotting:

```
Z = 20*SIN(X*Y)
X STARTING: -3
X ENDING: 3
Y STARTING: -3
Y ENDING: 3
N for AUTO SCALE
Z STARTING: -3
Z ENDING: 3
```



Very complicated three-dimensional plots can take several hours.

5 SAVING YOUR GRAPHICS

Devices are available that have the ability to take distortion-free pictures of the television image at the exact exposure settings necessary for photographic prints and slides. Two companies that supply equipment for hard-copy of the television screen are:

Image Resource
2260 Towngate Road
Westlake Village, California 91361
Phone: (805) 496-3317

Matrix Instruments
230 Pegasus Avenue
Northvale, New Jersey 07647
Phone: (800) 521-1596

6 GRAPH IT™ QUICK REFERENCE GUIDE:

BAR CHARTS

- **FACTORS:** Gives you the ability to stack three different colors (shades on black-and-white television) on a bar. Factors can be used to create alternating color bars. For example:

FACTOR 1: 35, 0, 25, 0
(COLUMNS alternate with 0)

FACTOR 2: 0, 22, 0, 55

- **COLUMNS:** Up to 32 columns of information.
- Ability to chart both negative and positive values.

PIE GRAPHS

- Percentages computed automatically from raw scores.
- Less than 1/14th of the total becomes **ETC.**
- Subtitle of PIE GRAPH is automatic when **RETURN** is pressed without entering a subtitle.

FEATURES OF TWO- AND THREE-DIMENSIONAL AND POLAR PLOTS

1. Ability to use all of the **BASIC** Language Function Library.
2. Ability to use **AUTO SCALING**. Assures that all of your plot will fit on the screen. If more than one function is plotted, the scale of the Y-axis may be different from the scale of the X-axis. This is done so that functions will not be clipped (peaks will not be chopped).
3. Ability to redefine or reenter the same function.
4. Ability to return to the program or change limits after the plot is completed.
To get the list of choices press any key. The program can then be reentered by typing **R** and pressing **RETURN**. To change limits type **C** and press **RETURN**.
5. Ability to use the computer's screen editing functions to make changes and corrections.

Unique capability of using Joystick controller for cursor readout.

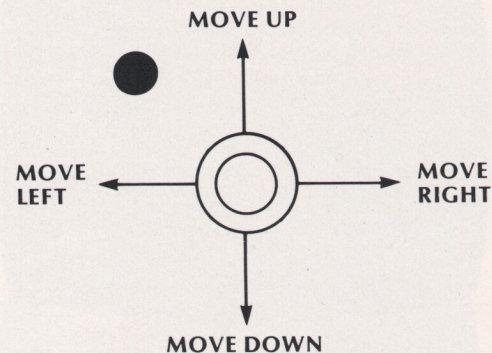

- Push the Joystick forward to have cursor appear on the screen.
- Move Joystick in direction you wish cursor to go.
- Press button for slope, X, Y, and Z coordinates.

7 APPENDIX

TWO-DIMENSIONAL X, Y ECONOMICS EXAMPLE: SUPPLY AND DEMAND

To get a visual idea of how supply and demand operate in the marketplace, it is hard to beat a graph. A look at the supply and demand for steel bolt number 9 tells a classic story. The supply of this bolt increases with its price. At higher prices, bolt manufacturers will buy more steel and hire more labor. The demand for a product, on the other hand, decreases as the price increases.

Economist Paul A. Samuelson calls this process "The law of downward-sloping demand." The law says, "When the price of a good is raised (at the same time that all other things are held constant), less of it will be demanded." People will start making do with fewer bolts as the price of bolts rises.

The supply of steel bolt number 9 can be written in **BASIC** as:

$$Y1 = 2 * X + 4 * X * X.$$

Using X^2 rather than X^2 increases plotting speed since multiplication is faster than exponentiation in **BASIC**. The value of X is the price in cents. The supply (Y_1) is in units of 100 bolts.

The demand for bolt number 9 is a straight-line equation: $Y_2 = 150 - 10 \cdot X$. The price of X is in cents per bolt. The demand for this bolt is in units of 100.

This example uses Side 2 of Cassette A, the TWO-DIMENSIONAL X, Y PLOTS program. Refer to page 3 for loading instructions. In response to **NUMBER OF FUNCTIONS**: type 2 **RETURN**. You are graphing two functions, supply (Y_1) and demand (Y_2). In the next screen display you define your function $Y_1 = 2 \cdot X + 4 \cdot X^2$ and hit **RETURN**. A new screen display will ask for Y_2 . For $Y_2 =$ type in the straight line equation $150 - 10 \cdot X$ **RETURN**.

Now you are asked for plotting speed. Type S **RETURN**, because it will give you the maximum number of plot points. The resolution (smoothness) of the curves will be improved but it will take slightly longer for the equation to plot. Also, the Joystick Controller will read with the highest X, Y and slope accuracy at the slowest speed.

For limits of X select a starting value of -1 **RETURN** and an ending value of 10 **RETURN**. You should choose not to use **AUTO SCALE** since you can get more plot points on the Y-axis by making your own Y limits. So press N **RETURN** for **AUTO SCALE**. When the screen display asks for minimum Y value, type -1 **RETURN**. For maximum Y value type 150 **RETURN**.

After the word **PLOTTING** vanishes from the screen use the Joystick Controller for a closer look at the X, Y and slope values. Plug in CONTROLLER JACK number 1 and press the Joystick toward the word **TOP**. The cursor will appear near the cross point of the two equations.

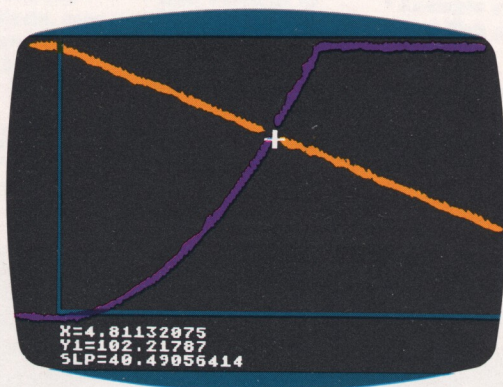

It's interesting to move up and down the supply and demand curves with the cursor. Economists have a special fondness for the point of intersection. "Ahhh, the equilibrium point!" they cry out. At the cross point, bolt number 9 sells for 4.8 cents and the demand is 102,000 units. The equilibrium price is always the intersection point of the supply and demand curves.

Moving the cursor up and down the supply curve gives the number of bolts that will be manufactured at different price levels. The slope of the supply curve will change as the curve gets steeper (the upper right hand corner of your screen). The demand, in this case history, has a constant slope, or rate of change - 40.3. The X and Y readouts along the two equations simulate the actual workings of the marketplace. If something should happen to the supply (e.g., the companies go on strike), then you would expect a new supply curve with a higher price intersection of the demand curve.

Keeping the demand equation the same, how many bolt number 9's will be sold at 9 cents? Right, by running the cursor to $X=9$ along the demand equation you see 59,000 will be sold. Make sure the cursor is reading the Y value of the downward sloping straight line at $X=9$. You can see that the supply is the limiting factor nearest the origin. Demand controls economic behavior after the equilibrium point.

The law of supply and demand works well to provide the correct number of manufactured goods at a fair price. Adam Smith, noted economist of a bygone era, has described the free enterprise system as being guided by an "invisible hand." Indeed, a correct reading of supply and demand gives the entrepreneur a pat on the back for the effort.

8 BIBLIOGRAPHY

Modley, R., and Lowenstein, D., *Pictographs and Graphs*. New York: Harper & Row, 1952.

Schmid, C.F., *Handbook of Graphical Presentation*. New York: Ronald Press, 1954.

Snyder, R.M., *Measuring Business Changes*. New York: John Wiley, 1955.

P. Abbot, *Algebra*, David McKay Co., Inc., New York, 1971.

John E. Freund, *Modern Elementary Statistics*, Prentice-Hall, Inc., New Jersey, 1952

Dyno Lowenstein, *Graphs*, Franklin Watts, New York, 1976.

Theodor E. Sterling, and Seymour V. Pollack, *Introduction to Statistical Data Processing*, Prentice-Hall, Inc., New Jersey, 1968.

Taro Yamane, *Mathematics for Economists*, Prentice-Hall, Inc., New Jersey, 1962.

David S. Moore, *Statistics—Concepts and Controversies*, W. H. Freeman and Company, San Francisco, Ca., 1979.

Brian Girling and Samuel M. Selby, *Standard Mathematical Tables*, The Chemical Rubber Co., 2310 Superior Avenue, Cleveland, Ohio 44114, 1964.

LIMITED 90-DAY WARRANTY ON ATARI® PERSONAL COMPUTER PRODUCTS

ATARI, INC. ("ATARI") warrants to the original consumer purchaser that this ATARI Personal Computer Product (not including computer programs) shall be free from any defects in material or workmanship for a period of 90 days from the date of purchase. If any such defect is discovered within the warranty period, ATARI's sole obligation will be to repair or replace, at its election, the Computer Product free of charge on receipt of the unit (charges prepaid, if mailed or shipped) with proof of date of purchase satisfactory to ATARI at any authorized ATARI Service Center. For the location of an authorized ATARI Service Center nearest you, call toll-free:

In California (800) 672-1430
Continental U.S. (800) 538-8547

or write to: Atari, Inc.
Customer Service Department
1340 Bordeaux Drive
Sunnyvale, CA 94086

YOU MUST RETURN DEFECTIVE COMPUTER PRODUCTS TO AN AUTHORIZED ATARI SERVICE CENTER FOR IN-WARRANTY REPAIR.

This warranty shall not apply if the Computer Product: (i) has been misused or shows signs of excessive wear, (ii) has been damaged by being used with any products not supplied by ATARI, or (iii) has been damaged by being serviced or modified by anyone other than an authorized ATARI Service Center.

ANY APPLICABLE IMPLIED WARRANTIES, INCLUDING WARRANTIES OF MERCHANTABILITY AND FITNESS FOR A PARTICULAR PURPOSE, ARE HEREBY LIMITED TO NINETY DAYS FROM THE DATE OF PURCHASE. CONSEQUENTIAL OR INCIDENTAL DAMAGES RESULTING FROM A BREACH OF ANY APPLICABLE EXPRESS OR IMPLIED WARRANTIES ARE HEREBY EXCLUDED. Some states do not allow limitations on how long an implied warranty lasts or do not allow the exclusion or limitation of incidental or consequential damages, so the above limitations or exclusions may not apply to you.

This warranty gives you specific legal rights and you may also have other rights which vary from state to state.

DISCLAIMER OF WARRANTY ON ATARI COMPUTER PROGRAMS

All ATARI computer programs are distributed on an "as is" basis without warranty of any kind. The entire risk as to the quality and performance of such programs is with the purchaser. Should the programs prove defective following their purchase, the purchaser and not the manufacturer, distributor, or retailer assumes the entire cost of all necessary servicing or repair.

ATARI shall have no liability or responsibility to a purchaser, customer, or any other person or entity with respect to any liability, loss, or damage caused directly or indirectly by computer programs sold by ATARI. This disclaimer includes but is not limited to any interruption of service, loss of business or anticipatory profits or consequential damages resulting from the use or operation of such computer programs.

REPAIR SERVICE

If your ATARI Personal Computer Product requires repair other than under warranty, please contact your local authorized ATARI Service Center for repair information.

IMPORTANT: If you ship your ATARI Personal Computer Product, package it securely and ship it, charges prepaid and insured, by parcel post or United Parcel Service.

